

Operator Manual

Petrol Cassette Mower

FT Series



DENNIS

Original Instructions in English (UK).

Part number: SP20001_EN.

Models covered: FT430 (D090) / FT510 (D060) / FT610 (D0100) / SS430 (D090JP) / SS510 (D060JP) / SS610 (D100JP).

Rev.	Date	Description of Changes	Author
9.0	12/ DEC/ 2025	Complete redesign of manual	C.B
10.0	14/ MAY/ 2026	Updates to overall section formatting. Multiple small updates throughout. Inclusion of SuperSix models.	C.B

For a digital copy of this manual, parts catalogue and other information regarding this product, please scan:



For a digital copy of the Honda engine documentation, please scan:



Serial numbers:

Chassis
Engine

Head Office

Howardson Works,
Ashbourne Road,
Kirk Langley,
Derbyshire,
DE6 4NJ,
UK
Tel: +44 (0) 1332 824 777
howardsongroup.com

Copyright © 1994-2026 by Howardson Group Ltd. All Rights Reserved.

This document and all content within it, is protected by copyright and is the property of Howardson Group Ltd. You may not distribute, modify, transmit, copy or use the content of this document in any way, electronic or otherwise, whether in whole or in part, for commercial purposes or for personal gain. Any storage, reproduction or redistribution of the content by any means is prohibited without prior written consent from Howardson Group Ltd. You may store extracts from this document for your personal use only.

While every effort has been made to ensure the accuracy and completeness of the information contained in this manual, we assume no responsibility or liability for errors or omissions. The information provided is on an "as is" basis without any warranties of any kind, either expressed or implied. We reserve the right to make changes to the product and its documentation at any time without prior notice. This includes, but is not limited to, modifications to the design, specifications, and functionality of the product. The latest version of the manual will be available on our website or through our customer service department. Some imagery may not reflect the actual product you have.

Table of Contents

1. Introduction and Safety Information	5
1.1. Introduction	5
1.1.1. Operator Manual Overview	5
1.1.2. Machine Description	5
2. Safety Information	6
2.1. Safety Statements	6
2.2. Warning Symbols	6
2.3. Safety Instructions	6
2.3.1. General Safety Instructions	7
2.3.2. Engine and Fuel Safety Instructions	7
2.3.3. Mechanical Safety Instructions	8
2.3.4. Noise and Vibration Safety Instructions	9
2.3.5. Personal Protective Equipment (PPE)	9
2.3.6. Intended Use and Residual Risks	9
2.3.7. Machine Decals	10
3. Assembly and Installation	11
3.1. Unpacking and Inspection	11
3.2. Assembly Instructions	11
3.3. Installation Requirements	11
3.4. Commissioning	12
3.5. Calibration	12
4. Machine Overview	13
4.1. Technical Specifications	13
4.1.1. Dimensions	13
4.1.2. Specification Table	14
4.1.3. Noise and Vibration	15
4.2. Machine Components	16
4.3. Control Components	19
4.4. Engine Components	21
4.5. Cassettes	22
5. Operation and Emergency Procedures	25
5.1. Pre-Start and Safety Checks	25
5.2. Cutting Preparation	25

5.2.1. Removing and Inserting a Cassette	25
5.2.2. Adjusting Height (Cutting)	26
5.2.3. Adjusting Height (Scarification, Dethatching and Brushing)	28
5.2.4. Handlebar Height Adjustment	30
5.2.5. Shear Blade Adjustment	30
5.3. Engine	32
5.3.1. Safety Information	32
5.3.2. Refuelling	32
5.3.3. Installation and Removal	32
5.3.4. Engine Specifications	32
5.3.5. Replacement and Disposal	32
5.4. Starting the Engine	33
5.5. Stopping the Engine	34
5.6. Drive	35
5.6.1. Moving and Transport (no cut)	35
5.6.2. Operating on Slopes	36
5.7. Cutting	36
5.7.1. Moving and Cutting (including scarify/brush)	36
5.7.2. Cutting Technique	37
5.8. Operating Environment	38
5.9. Emergency Procedures	39
5.9.1. In the Event of a Breakdown	39
5.9.2. Hazardous Substances and Fire	39
6. Maintenance and Servicing	41
6.1. Maintenance Schedule	41
6.2. Servicing Instructions	44
6.2.1. Cassette and Drive Belt Replacement/Tensioning	44
6.2.2. Backlapping	46
6.2.3. Grinding Cutting Blades	47
6.2.4. Changing Rear Roller Oil	49
6.2.5. Oiling Dog Clutch	49
6.2.6. Greasing points	50
6.3. Cleaning	50
6.4. Handling and Transport	51

Table of Contents

6.5. Storage51
6.6. Disposal52
6.6.1. Machine Disposal52
6.6.2. Hazardous Materials52
6.7. Troubleshooting & FAQ52
6.8. Warranty Policy52

Appendix **53**

Appendix A. Optional Items and Attachments53
A1. Weile (Grooved) Roller53
Appendix B. Service Kit54
Appendix C. Troubleshooting & FAQ54

List of Key Figures

Fig.1. Viewpoints	5
Fig.2. Grass Box Attachment	11
Fig.3. Machine components overview.	16
Fig.4. Serial plate components overview.	17
Fig.5. Cassette Clutch Rod engagement points.	19
Fig.6. Control components overview.	19
Fig.7. Engine components overview.	21
Fig.8. Removing and Inserting a Cassette	26
Fig.9. Adjusting Height of Cut	27
Fig.10. Setting bar measurement for above/below ground cassettes.	29
Fig.11. Handlebar adjustment	30
Fig.12. Shearblade adjustment	31
Fig.13. Power on procedure	33
Fig.14. Power off procedure	34
Fig.15. Driving procedure	35
Fig.16. Cutting procedure	37
Fig.17. Drive belt replacement / tensioning	45
Fig.18. Backlapping	47
Fig.19. Recommended cylinder grind angle	48
Fig.20. Recommended shear blade grind angle	48
Fig.21. Illustration of two different shear blade angles and their grass contact point	48
Fig.22. Rear roller oil	49
Fig.23. Dog Clutch Oiling	49
Fig.24. Anchor points for transport.	51
Fig.25. Front roller removal	53

1. Introduction

1.1. Introduction

1.1.1. Operator Manual Overview

This operator manual contains important information regarding the safe, proper and efficient operation of the FT/SS430, FT/SS510 and FT/SS610, referred to as 'machine' in this manual. This operator manual must always be available and read by every User of the machine. 'User' is defined as an authorised person tasked with working on or with the machine, typically operators, groundskeepers and maintenance personnel.

Adherence to this operator manual will help to avoid and minimise risk to you as the User and to the machine. It will also lead to a greater quality of cut, lower repair costs and reduce downtimes. Prior to use, every User must ensure they have:

- Fully read and understood these instructions,
- Understood the machine controls,
- Understood the dangers and hazards involved, and methods to mitigate risk.

Reference will be made to the use, safety and maintenance of the petrol engine. However this is supplementary information only and you must also read the supplied OEM manual for the engine.

In the case of any difficulty or if further information is required, call Howardson Group or your Dealer. In the interests of speed and accuracy of information, please quote the serial number of the machine when making enquiries.

Location descriptions (e.g. left/right hand) throughout this manual are observed from the operators view whilst in normal drive position, as per Fig.1.

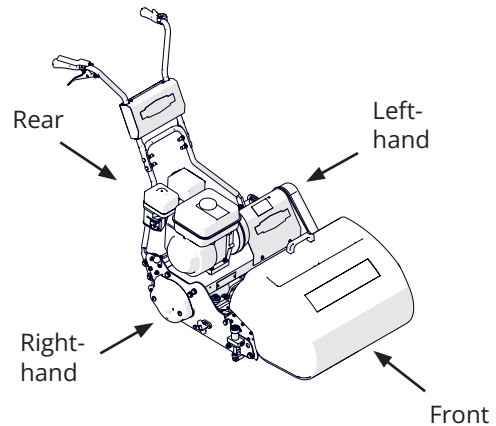

Fig.1. Viewpoints

1.1.2. Machine Description

The FT/SS430, FT/SS510 and FT/SS610 are professional petrol grass mowers, using a 430mm (17"), 510mm (20") or 610mm (24") cassette respectively. These cassettes are interchangeable, each used for a different application including cutting, brushing, scarifying, verti-cutting and sorrel rolling.

All models are powered by an air cooled, single cylinder, four stroke petrol engine, the specification of which can be found in the supplied OEM manual, or selected specifications in this manual.

The rear roller and cassette are controlled independently, with the rear roller operated from the handlebar and the cassette from a engagement knob on the side.

The design of the machine incorporates a system for quick adjustment of the height of cut and a sectional assembly system for easy service and maintenance of the main components. A mechanical parking brake is fitted which stops uncontrolled rolling when left unattended.

2. Safety Information

2.1. Safety Statements

Throughout this manual, potential safety risks are identified with a word and coloured coded box. They denote the following:

 **DANGER**
Indicates an imminently hazardous situation which, if not avoided, will result in death or serious injury.

 **WARNING**
Indicates a potentially hazardous situation which, if not avoided, could result in death or serious injury.

 **CAUTION**
Indicates a potentially hazardous situation which, if not avoided, may result in minor or moderate injury.

 **NOTE**
Indicates information considered important but not hazard related.

2.2. Warning Symbols

The following warning symbols are used throughout this Operator Manual and across the machine. Familiarise yourself with them prior to operating the machine. They are located near areas of potential danger or convey further information on machine use.

Warning Signs



General warning sign



Warning; Sharp element

Prohibition Signs



General prohibition sign

Mandatory Signs



General mandatory action sign



Refer to instruction manual/booklet



Wear ear protection



Wear eye protection



Wear protective gloves



Wear safety footwear

Other Signs



Take note



Heavy weight

2.3. Safety Instructions



DANGER - SAFETY INSTRUCTIONS

This machine can cause serious injury if it is not used correctly. Before use, carefully read all following safety instructions and the potential hazards that could occur. It is essential they are adhered to.

Failure to follow the safety information and correct operating procedures may result in serious injury or death.

2. Safety Information

2.3.1. General Safety Instructions



WARNING - GENERAL SAFETY INSTRUCTIONS

This machine contains mechanical and combustion engine related hazards. **Always** read this operator manual carefully, taking care to understand all safety instructions.

Training and Access

- Read and understand all instructions and machine hazards before use.
- Only trained and authorised personnel may operate the machine.
- The machine owner must ensure the manual is accessible to all users at all times.

Area Safety and Exclusion

- Never allow children to operate the machine, enter the work area or access the machine while in storage.
- Maintain a safe distance from pedestrians and remain alert to your surroundings.
- Prevent any unauthorised person from interacting with the machine under any circumstances.

Safe Operation

- Always keep both hands on the handlebar.
- Never exceed a standard walking pace.
- Operate only within the specific environmental conditions defined in "**5.8. Operating Environment**" p.38.

Fitness for Work

Do **not** operate the machine if your judgment or physical ability is impaired by:

- Illness or fatigue.
- Reduced physical capacity.
- The influence of drugs or alcohol.

2.3.2. Engine and Fuel Safety Instructions



WARNING - ENGINE AND FUEL SAFETY

This machine uses petrol and contains hot engine components. Incorrect handling poses a risk of fire, explosion, carbon monoxide exposure or serious burns. Always follow the guidance shown.

Fuel Handling

- Always use regular unleaded petrol only (pump octane rating 86 or higher). Using the wrong fuel will damage the engine.
- Always refuel outdoors with the engine switched off and cool. Never add fuel while it is running.
- Never smoke or use naked flames near petrol or the fuel system.
- Always wear correct PPE when handling fuel.
- Do not overfill the fuel tank.
- Clean up spilled fuel immediately. Ensure the engine is started a safe distance away from the spill after cleaning up.
- Never start or operate the machine if you suspect a leak.
- **Flammable risk** - Always store the petrol in a suitable container, away from direct sunlight, high temperatures and areas with risk of sparks.

Engine Operation

- This manual includes general guidance for the operation and maintenance of the engine. Always read the OEM engine 'Owner's Manual' provided for specific instructions and safety information not covered in this manual.

Note the following:

- The OEM engine manual takes precedence for all engine technical specifications.
- The recommended service intervals covered in this Operator Manual may

2. Safety Information

differ to the OEM. In cases of discrepancy, follow the more frequent service interval.

- Only operate the engine in open, well-ventilated areas. Exhaust gases contain carbon monoxide and other toxic gases that can be fatal if accumulated.
- Always disengage the drive and cylinder levers before starting the engine. Start the engine carefully following the instructions.
- Keep the exhaust, fuel tank and surrounding engine parts free from grass, debris, and oil build-up.
- Do not tilt the mower excessively while the engine is running.
- Never change engine governor settings or overspeed the engine.
- Never carry out adjustments whilst the machine is running.

Hot Surfaces

- Engine components and the exhaust system become extremely hot during operation and remain hot long after use. Never touch engine parts until the machine has fully cooled.
- Allow the engine to cool completely before storing or carrying out any maintenance.
- Keep clothing, hands, feet, and combustible materials clear of hot surfaces at all times.
- Never place anything in the engine due to fire risk.

Maintenance and Inspection

- Always keep the engine maintained with the schedule and procedures found in "**6. Maintenance and Servicing**" p.41 and in the maintenance section of the OEM engine 'Owner's Manual'.
- Allow the engine to cool completely before refuelling, storing, transporting, servicing or performing maintenance.
- Always switch off the engine and disconnect the spark-plug lead before cleaning, inspect-

ing or servicing.

- Inspect the fuel tank, fuel lines, cap and fittings regularly. Do not operate the machine if any part of the fuel system is damaged or leaking.
- Use only genuine replacement parts to maintain correct safety and performance.

Prohibitions

- Never open, modify or attempt to repair internal engine or fuel components. Strictly for qualified personnel only. Incorrect repair can cause fire, explosion, or severe injury.
- Never puncture, crush, incinerate, immerse in water or tamper the engine in any way - risk of fire or explosion.

2.3.3. Mechanical Safety Instructions



WARNING - MECHANICAL SAFETY INSTRUCTIONS

This machine contains sharp, fast-moving parts. Improper use can result in serious injury. Always keep all body parts away from rotating components, which may continue to move after power-off. Never operate without protective guards or bypass safety devices.

Vigilance

- Components such as blades, brushes and rollers can continue to rotate for a short period after the machine is switched off; maintain full attention until all motion has completely ceased.
- If any component is damaged, loose or excessively worn, **stop using the machine immediately.**

Maintenance and Inspection

- Carry out maintenance checks as shown in "**6.1. Maintenance Schedule**" p.41 to ensure safe and reliable operation.
- All servicing and repair must be carried out

2. Safety Information

by a suitably qualified person using genuine parts.

2.3.4. Noise and Vibration Safety Instructions



WARNING - NOISE AND VIBRATION SAFETY INSTRUCTIONS

This machine generates noise and low levels of mechanical vibration during normal use. Always use hearing protection to allow safe, extended operation and prevent long-term health risks associated with noise exposure.

Consult local regulations for vibration exposure limits. Do not exceed the maximum allowable duration for machine operation.

- If abnormal noise or vibration is detected, stop using the machine immediately and inspect it for damage or wear.
- Ensure all maintenance is carried out as specified to keep noise and vibration levels within their intended limits.

2.3.5. Personal Protective Equipment (PPE)

During use you must adhere to local rules and regulations regarding Personal Protective Equipment (PPE). In addition to this we recommend to wear:



- **Footwear;** heavy duty, slip resistant boots to protect against injury.



- **Eye protection;** to protect from flying debris.



- **Hearing protection;** must be worn at all times when the machine is activated.



- **Clothing;** suitable for the environment you are operating in (hot, cold, wet etc)



- **Hand protection;** to avoid cuts and blisters.



- **Respiratory protection;** for when there are occurrences of high dust and pollen.

2.3.6. Intended Use and Residual Risks



WARNING - INTENDED USE AND RISK

This machine is designed solely for cutting fine grass surfaces. Never use the machine for anything else other than this purpose. Personal injury and damage to the machine can result in using the machine for alternative uses.

Limitations

- Do not use the machine to cut grass above the maximum specified cutting height, or to cut thick, coarse vegetation expected for the use of different equipment (e.g. brushcutters or strimmers).

Prohibited Operations

- Do not ride on the machine, tow it, or use it to carry loads or transport goods.
- Do not use the machine as a general-purpose tool for any task other than fine grass cutting.
- Do not modify the machine or fit non-approved attachments.

Surfaces

- Do not operate the machine on surfaces other than grass (e.g. gravel, bare soil, hard surfaces). Operating on other terrain may cause damage or create hazards (such as flying debris).

2. Safety Information

2.3.7. Machine Decals

Your machine decals must be replaced when they become worn or damaged. Contact Howardson Group Service department with the part number listed below:



229599



229375



229376

Cut on/off decal



B32903_REV0

United Kingdom Flag



SP18037 (95dB)

Noise Decal



B32902_REV2 -

(200x50mm)

Dennis Logo Decal



Oil daily warning sticker

3. Assembly and Installation

3.1. Unpacking and Inspection

The machine will arrive on a wooden pallet base, with either a cardboard or wooden outer frame. Carefully remove this outer packaging. You alternatively may have the machine delivered direct from our factory or your Dealer.

Visually inspect the machine for any signs of damage which may have occurred during transport. Contact Howardson Group or your Dealer as soon as possible should there be damage.

Included with the machine is this operator manual, a warranty registration document and machine parts catalogue.

To remove the machine from the pallet:

1. Remove all tie-down straps.
2. Wherever possible, use a suitably rated ramp to roll the machine off backwards to the ground. Refer to section **"5. Operation and Emergency Procedures" p.25** and its subsections for the relevant procedures. Gently toggle the park brake on/off to aid going down the ramp.



CAUTION - MACHINE WEIGHT

The machine is very heavy. Machine weight can be found on the serial plate or section **"4.1.2. Specification Table" p.14**. Take care when removing from the wooden pallet - we recommend two people to help with this. Follow all manual handling techniques for your business and region.

3. If a ramp is not available, disengage the parking brake and, while following correct manual handling techniques, **gently** lower the rear roller to the floor. Continue to roll backwards, keeping pressure on the handlebar so the front wheels remain in the air. Once clear of the pallet, lower the front to the floor **gently**.

Dispose of all packaging according to local laws - recycle where possible.

3.2. Assembly Instructions

Minimal assembly is required to get your machine into a ready state:

1. **Attach the grass box;** lower the grass box onto the machine using the pin and notch of the grass box to the corresponding cut-out and tie-bar on the machine. (Fig.2), removing any plastic wrapping that may be left.
1. **Set handlebar height;** the handlebar may need readjusting to be optimum for your height. See section **"5.2.4. Handlebar Height Adjustment" p.30** for further information.
2. **Fill the fuel tank** with unleaded petrol (see OEM manual supplied for more information).

Fig.2. Grass Box Attachment

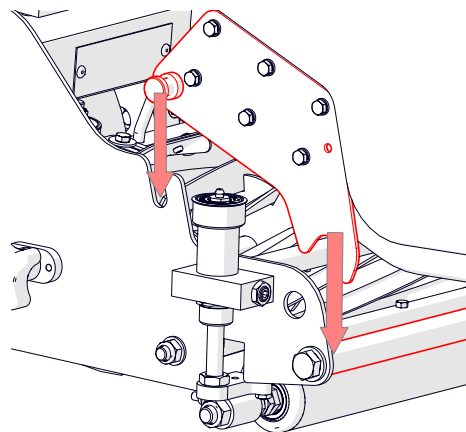

3.3. Installation Requirements

Adjustments will be required to make adequate space for the storage and routine maintenance of the machine:

- See section **"4.1.1. Dimensions" p.13** for minimum space requirements.
- See section **"6.5. Storage" p.51** for correct storage requirements.

3. Assembly and Installation

3.4. Commissioning

Your Dealer or a Howardson Group representative will be present to commission and set-up your machine. They will walk through the process of basic controls and getting started with your machine.

3.5. Calibration

No calibration procedures are required.

4. Machine Overview

4.1. Technical Specifications

4.1.1. Dimensions

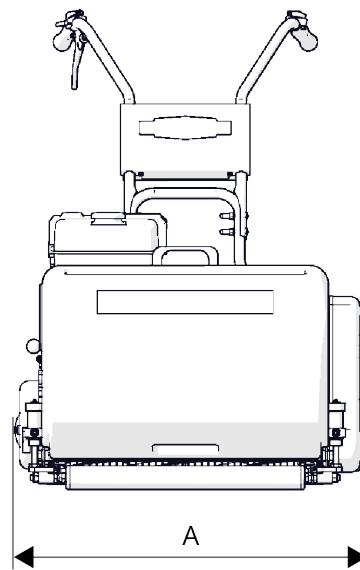
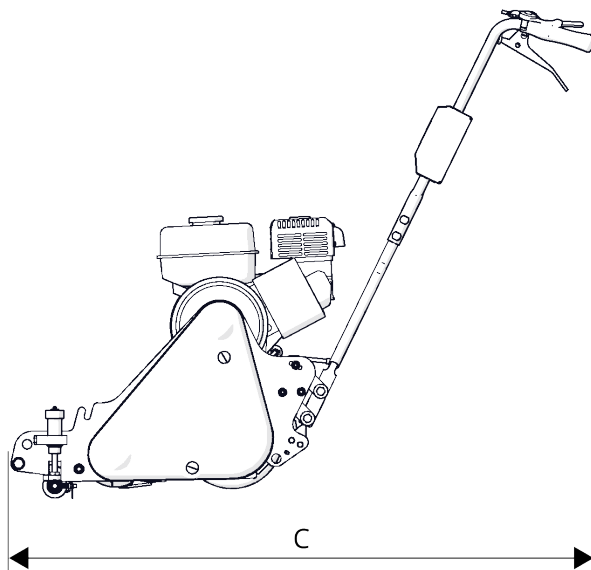
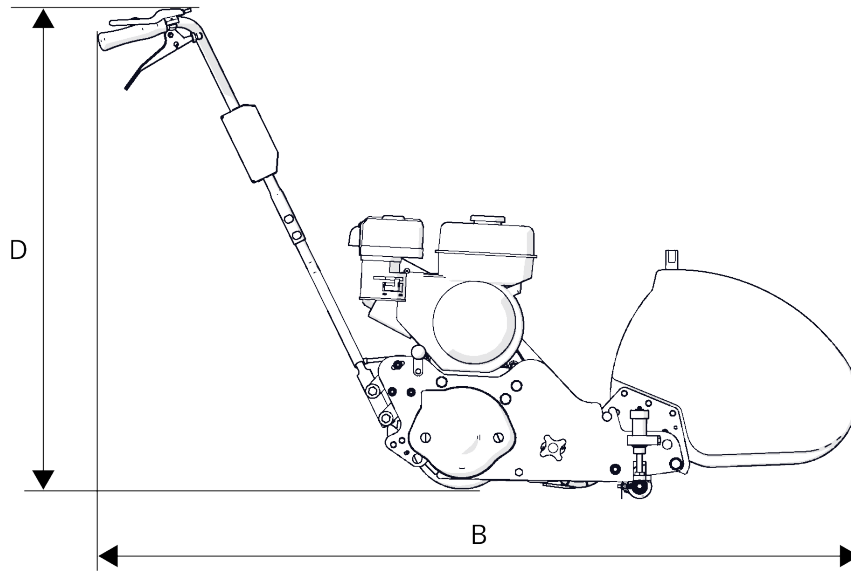

View	Model		
	FT430 / SS430	FT510 / SS510	FT610 / SS610
A	675mm	750mm	840mm
B	1592mm		
C	1229mm		
D	971mm		

4. Machine Overview

4.1.2. Specification Table

System		Model		
		FT430 / SS430	FT510 / SS510	FT610 / SS510
Weight	Machine	96 kg	102 kg	107 kg
	Cassette only	See "4.5. Cassettes" p.22		
Drive	Engine ¹	Type	Petrol Engine	
		Model	Honda GX120	Honda GX160
		Net Power	2.4 kW / 3,600 rpm	3.6 kW / 3,600 rpm
		Fuel Tank Capacity	3.1 L	
		Engine Oil Capacity	0.6 L	
		Engine Oil Type	Genuine Honda, SAE 10W-30	
		Dry Weight	13.2 kg	15.1 kg
		Spark Plug Type	BPR6ES (NGK) or W20EPR-U (DENSO)	
		Spark Plug Gap	0.7-0.8mm	
	Rear Roller System	'V' Belt		
	Cassette Drive System	Multi 'V' Belt		
	Rear Roller Diameter	214 mm		
	Front Roller Diameter	FT models - 51 mm SS models - 89 mm		
	Speed (maximum)	Forwards	3.77 km/h	
Cutting	Blade unit	Cassette - removable		
	Cutting Width (mm) [inches]	430 mm [17"]	510 mm [20"]	610 mm [24"]
	Number of blades	5 / 10		
	Height of cut (mm)	03-20 mm		
	Clips per Metre	5 blade	66	
		10 blade	132	
Grassbox volume (L)	80 L	97 L	110 L	

4. Machine Overview

System		Model		
		FT430 / SS430	FT510 / SS510	FT610 / SS510
Environmental	Operating temperature range	-20°C to +40°C (+10°C to +30°C optimal)		
	Storage temperature range	-20°C to +35°C For additional information, see section "6.5. Storage" p.51.		

¹For technical specifications of the engine, please refer to the 'Owner's Manual' supplied.

4.1.3. Noise and Vibration



WARNING - NOISE AND VIBRATION

This machine generates noise and low levels of mechanical vibration during normal use. Always use hearing protection to allow safe, extended operation and prevent long-term health risks associated with noise exposure.

System		Model		
		FT430	FT510	FT610
Noise	Measured Sound Power Level	92 dB(A)	92 dB(A)	92 dB(A)
	Guaranteed Sound Power Level	96 dB(A)	95 dB(A)	95 dB(A)
Vibration	Total value to which the hand-arm system is subjected (m/s ²)	4.0	4.0	4.0

4. Machine Overview

4.2. Machine Components

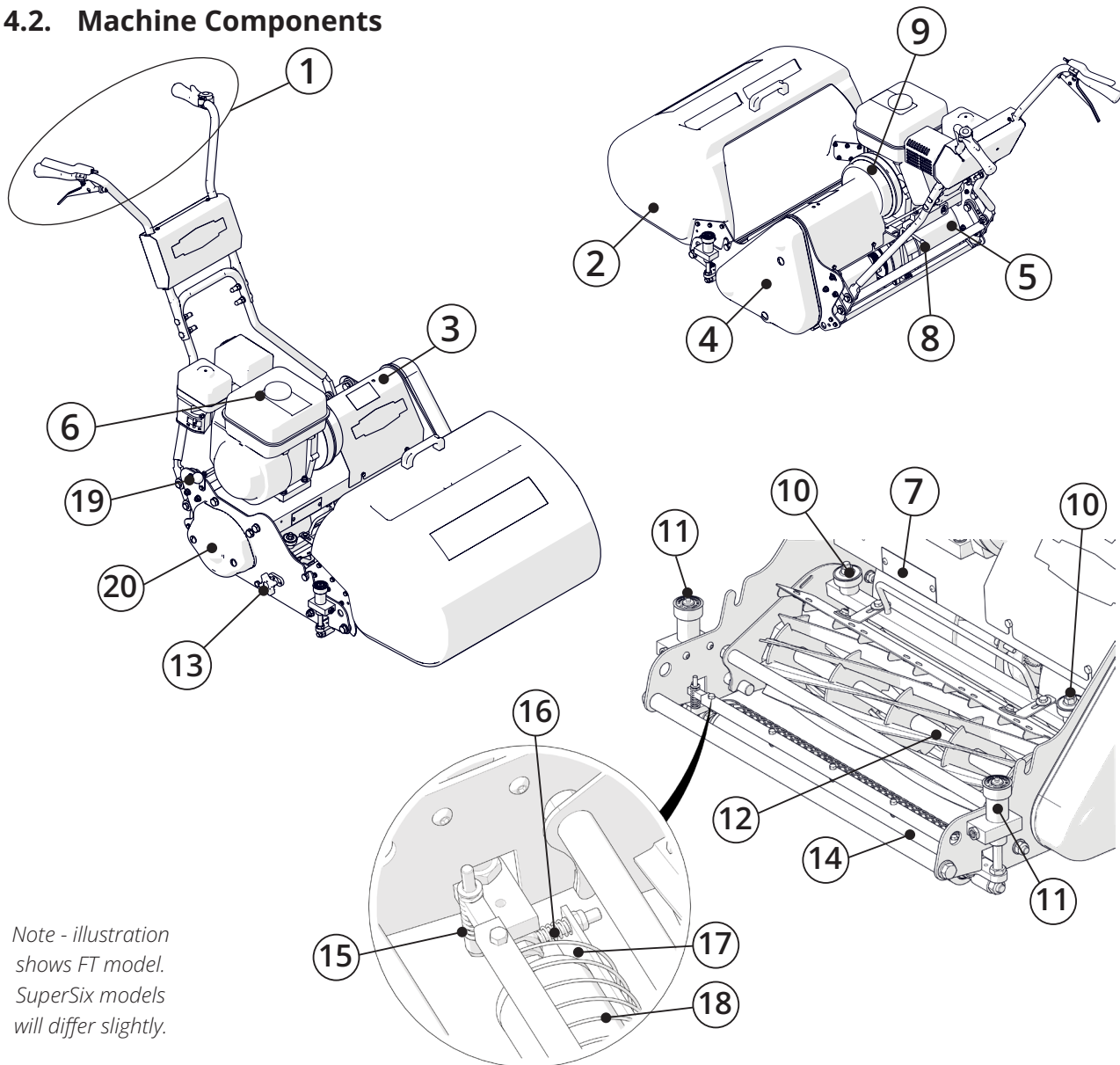

Note - illustration shows FT model. SuperSix models will differ slightly.

Fig.3. Machine components overview.

- | | |
|--|---|
| <ul style="list-style-type: none"> 1. Control Components 2. Grass Box 3. Top Drive Guard 4. Side Drive Guard 5. Rear Roller 6. Engine 7. Serial plate 8. Parking Brake 9. Centrifugal Clutch Drum 10. Shear Blade Adjuster | <ul style="list-style-type: none"> 11. Cut Height Adjuster 12. Cassette; <i>type depending on order</i> 13. Cassette Retaining Pin 14. Front Roller 15. Comb Tine Height Adjuster (<i>N/A for SuperSix</i>) 16. Front Roller Scraper Bar Adjuster (<i>N/A for SuperSix</i>) 17. Scraper Bar 18. Comb Tine (<i>N/A for SuperSix</i>) 19. Cassette Clutch Rod 20. Brake Cover |
|--|---|

4. Machine Overview

1. Control Components

See "4.3. Control Components" p.19.

2. Grass Box

The grass box collects the clippings from the cassette. Remove/attach to the machine by using the pin and notch of the grass box to the corresponding cut-out and tie-bar on the machine.

Maximum volume: FT430 = 80L, FT510 = 97L, FT610 = 110L.

3. Top Drive Guard

Under the top drive guard is the main drive shaft and dog clutch mechanism for the cassette. Two holes in the guard allow direct access for oiling the dog clutch, see "6.1. Maintenance Schedule" on page 41.

This guard protects the operator and machine from injury and damage. It must be kept on and secured at all times.

4. Side Drive Guard

Behind the side guard is a belt and pulley assembly to split power from the engine to both cassette and rear roller. The guard must be kept on and secured at all times.

5. Rear Roller

The rear roller maintains stability along with the front roller, but also creates a striping effect behind the machine. It is split into three segments, with the two outer segments operated by differential to aid in manoeuvrability.

6. Engine

Refer to supplied OEM manual and "4.4. Engine Components" p.21 for further information.

7. Serial Plate

The serial number can be found on the chassis between the engine and cassette. Please make a note of the serial number of your machine and engine in the table found on the inside cover of this manual. Always quote these in any communication with Howardson Group.

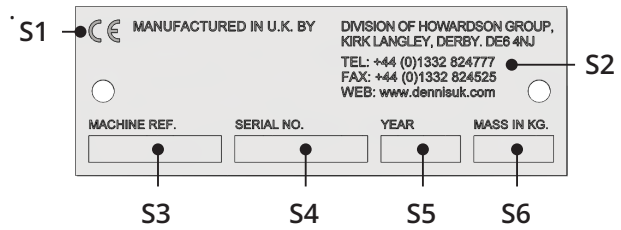

Fig.4. Serial plate components overview.

- S1. CE marking
- S2. Business/manufacturer address and contact details
- S3. Machine code designation
- S4. Serial number
- S5. Year of build
- S6. Mass of machine (kg)

8. Parking Brake

The mechanical parking brake physically stops the rotation of the rear roller when engaged. This stops any unintended rolling and is to be used when the machine is not in use. The mechanism features a 'C' shaped cut-out that guides the brake lever/pad ensuring it secures into position. Push forward and around the inner curve to engage brake, or pull back and around to disengage.



- **Always** engage the parking brake when the machine is not in use.
- Do **not** use the parking brake to stop the machine while moving. This may result in damage to the braking system. To stop, release the drive/speed lever and the machine will slow to a stop.

9. Centrifugal Clutch Drum

The centrifugal clutch drum is a key component that allows a smooth transition of power from the engine to the rear roller and cassette. The design means the engine has to reach optimal speed and torque before the clutch drum engages. This

4. Machine Overview

design ensures smooth engagement and helps prevent strain on engine components. At low engine revolutions (e.g., idle or light throttle), the driveshaft speed is insufficient to generate enough centrifugal force to overcome the internal springs holding the clutch shoes in place. As engine speed increases, the centrifugal force becomes strong enough to push the clutch shoes outward, causing their friction pads to engage with the drum's inner surface and rotate it, thereby transmitting power.



Always keep all body parts away from the centrifugal clutch drum while the engine is on. Risk of injury and trapped limbs.

10. Shear Blade Adjuster

Over time the quality of cut will decrease due to blade wear. Adjustment of the shear blade carrier is required to maintain the cut "*5.2.5. Shear Blade Adjustment*" p.30.

11. Cut Height Adjuster

Located either side of the machine, cut height is adjusted here. FT models are supplied with a click height adjuster with quarter turn 'clicks' of 0.25mm increments. SuperSix models are supplied with a quadrant and knob assembly. See "*5.2.2. Adjusting Height (Cutting)*" p.26.

12. Cassette

The cassette is an interchangeable piece of equipment which can alter the function of the machine. Using the cassette motor, the machine can use this power to perform different lawn care duties, including cutting, brushing and scarifying - for the full list of cassettes, see "*4.5. Cassettes*" p.22

It is designed to be easily changed, changing the function of the machine in a matter of minutes. Replace worn or damaged cassettes with genuine Dennis replacements.



DANGER - CASSETTE BLADES/DISCS

Worn or damaged blades/discs are dangerous. Incorrect use or maintenance can cause serious injury or death. Inspect before and after every use, as per "*6.1. Maintenance Schedule*" p.41

Always inspect the blades/discs with the machine **off** and the key removed.

13. Cassette Retaining Pin

Used to secure the cassette in place. Check prior to use to ensure it is secure. Do not over-tighten.

14. Front Roller

The front roller maintains stability and guides the machine. As standard, a Smooth roller is supplied but a Weile roller is available as an optional extra. SuperSix models are supplied with a larger diameter front roller.

15/16. Comb Tine Height / Front Roller Scraper Bar Adjuster

These adjustment points allow for the height to the comb tines/gap between front roller and scraper, to be changed. Use a 10mm spanner to adjust accordingly.

17. Scraper Bar

Removes soil and debris attached to the front roller. This avoids clumping, allows for easier steering and improved cutting performance. Recommended to leave a gap of 1-3mm between scraper bar and front roller.

18. Comb Tine

Used to lift and 'present' grass blades prior to being cut. Adjust using a 10 mm spanner, so the tines hang below the height of cut (determined by shear blade height).

19. Cassette Clutch Rod

This rod engages or disengages power to the cassette. Lift and push in to disengage, lift and pull outwards to engage. A hex nut separates the engagement/disengagement points. Perform

4. Machine Overview

either of these actions at low engine speed when the centrifugal clutch drum is not spinning as to avoid grinding components.

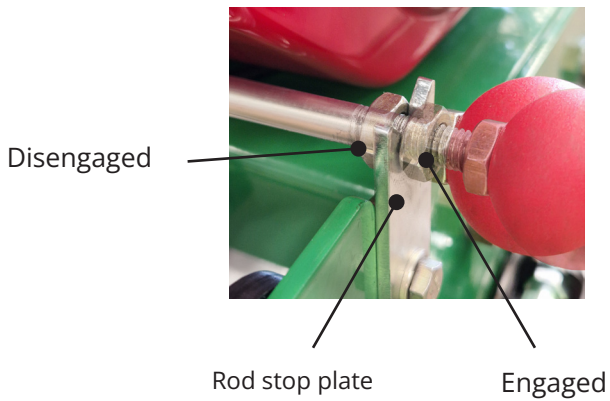

Fig.5. Cassette Clutch Rod engagement points.

20. Brake Cover

This cover protects the brake drum and brake band ring. Access inside is required for periodic maintenance but not daily operation.

4.3. Control Components

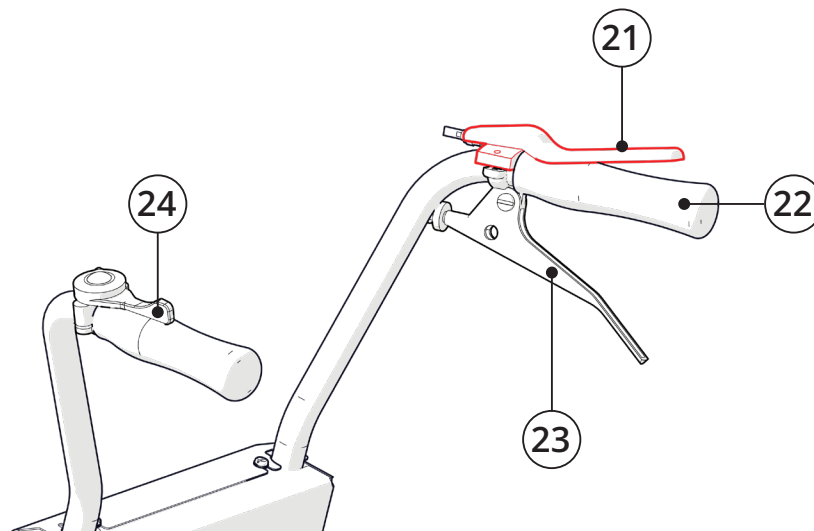

Fig.6. Control components overview.

21.Operator Presence Control (OPC)

23.Drive/Speed Lever

22.Operating Handle

24.Throttle Lever

4. Machine Overview

21. Operator Presence Control (OPC)

This lever mechanism is a safety feature to prevent accidents. It signals to the machine of your control, active or otherwise, and either supplies or stops power to the cassette and rear roller respectively.

The OPC requires continuous engagement to provide power to the cassette and rear roller. When released, this indicates you are no longer present or in control. At this, the machine immediately ceases all power to the cassette and rear roller, regardless of lever position. This minimises risk caused by the machine being able to operate unattended or in unsafe conditions.



DANGER - BYPASSING OPC

Never interfere or tamper with the OPC in any way. This includes taping, tying up or any other modification. Doing so bypasses a key safety mechanism of the machine and puts you and fellow pedestrians at risk.

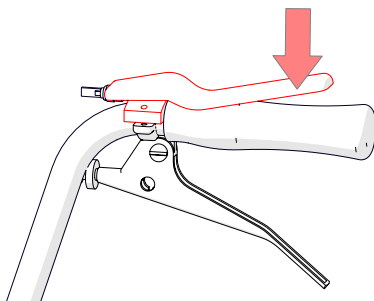

Fig.6A - OPC

22. Drive/Speed Lever

This lever engages power to the rear roller when there is sufficient power, as indicated by a spinning centrifugal clutch drum (9). Squeeze up towards the operating handle to engage (i.e. start moving forward), or release to disengage (i.e. stop moving). Speed is proportional to the pressure given, so a stronger squeeze will result in a faster machine.

This lever must be used in conjunction with the OPC to be operated. Only engage when it is safe to do so.

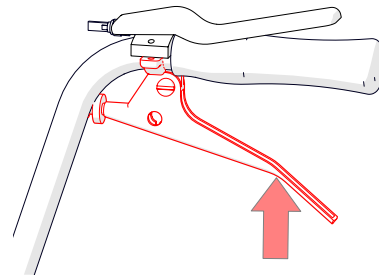

Fig.6B - Drive/speed lever

24. Throttle Lever

This lever alters the speed of the engine only, *not* directly the speed of the machine. To allow drive or cassette spin to occur, the engine speed must be sufficient to spin the centrifugal clutch drum (9). To achieve this, turn the throttle towards here until the centrifugal clutch drum spins.

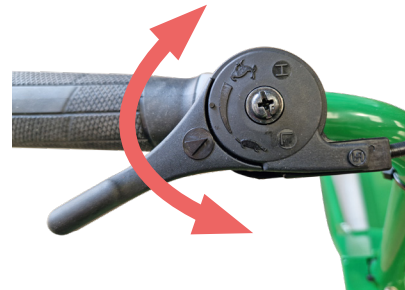

Fig.6C - Throttle lever

4. Machine Overview

4.4. Engine Components

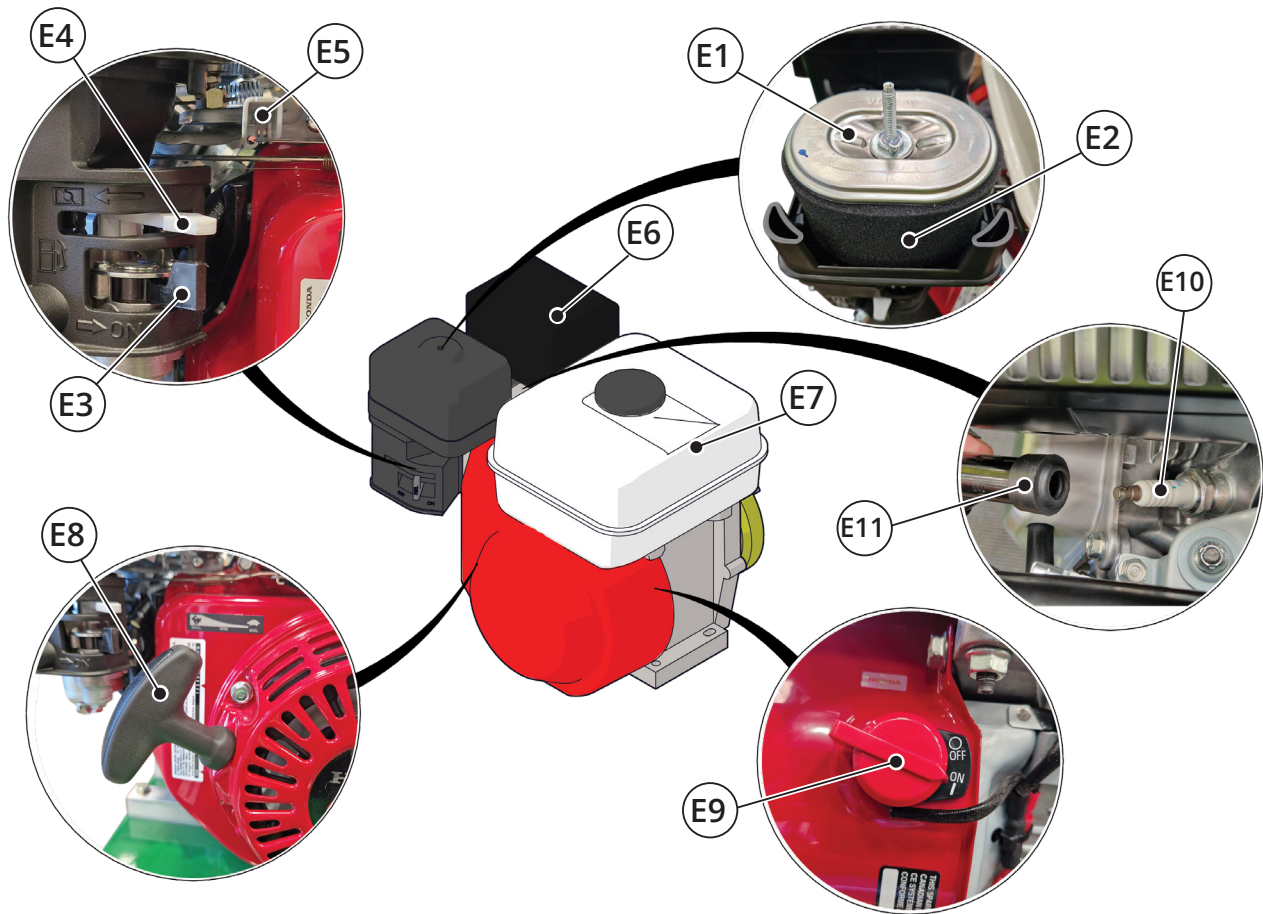

Fig.7. Engine components overview.

E1. Air Filter (paper)

E2. Air Filter (foam cover)

E3. Fuel Lever

E4. Choke Lever

E5. Throttle Control Lever

E6. Exhaust

E7. Fuel Tank

E8. Starter Grip

E9. Engine On/Off

E10. Spark Plug

E11. Spark Plug Cover





Please refer to supplied OEM 'Owner's Manual' for description and use of each of the above components.

4. Machine Overview

4.5. Cassettes

Twelve interchangeable cassettes are available for all FT-Series machines. These are model specific and cannot be used interchangeably (i.e. a FT430 cassette cannot be used in a FT510/FT610 machine and vice versa). Different cassette types are available for various grounds-care work, as outlined in the following table. With exception of the sorrel roller, they are all powered by the cassette pulley assembly allowing for easy interchangeability (the sorrel roller is free spinning and does not have the means to engage with the cassette drive).

For instructions on removing the cassette, see **"5.2.1. Removing and Inserting a Cassette" p.25.**

Type	Description and Use	Weight (kg)		
		FT430	FT510	FT610
Cutting	5 Bladed Cylinder			
	 <p>Five steel blades in a spiral format. Good general purpose cylinder and ideal for use on longer grass. As standard, no relief grind.</p>	TBC	18.7	21.6
Cutting	10 Bladed Cylinder			
	 <p>Ten steel blades in a spiral format. Higher clip rate compared to 5 bladed cylinder and ideal for short length grass. As standard, relief grind.</p>	TBC	21.3	24.6
Brushing	Brush			
	 <p>For moss and debris removal and use as a light scarifier for final pre-cut preparations.</p>	TBC	11.0	TBC
Brushing	Brush Multi-Dense			
	 <p>For moss and debris removal and use as a light scarifier for final pre-cut preparations.</p>	TBC	11.2	12.8

4. Machine Overview

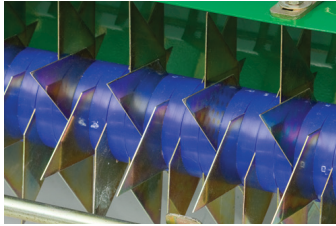
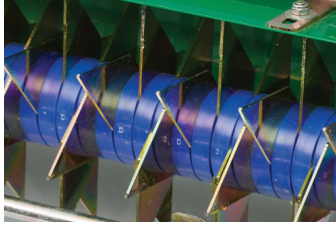
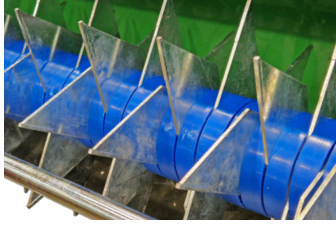
Type	Description and Use	Weight (kg)			
		FT430	FT510	FT610	
1mm Scarifier					
Scarifying		1mm thick replaceable, wear resistant blades. 12mm spacing for thatch removal throughout the season and autumn/spring renovation work.	TBC	11.5	TBC
	2mm Scarifier				
		2mm thick replaceable, wear resistant blades. 12mm spacing for thatch removal throughout the season and autumn/spring renovation work.	TBC	12.8	14.6
2mm Scarifier Tungsten Tipped					
	2mm thick replaceable, tungsten tipped blades. Designed for heavy duty thatch removal throughout the season and autumn/spring renovation work.	TBC	12.8	14.6	

4. Machine Overview

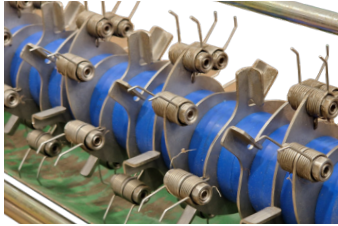
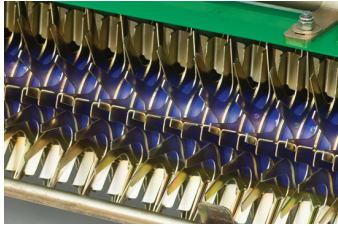
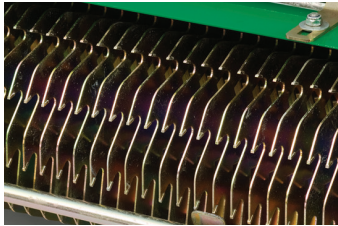
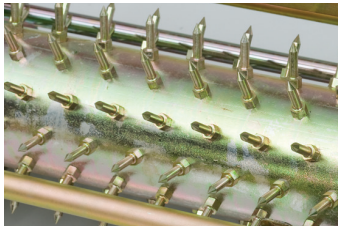
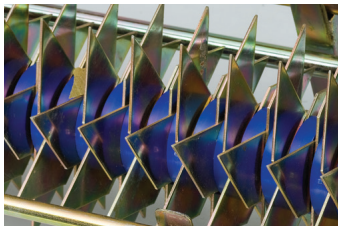
Type	Description and Use	Weight (kg)		
		FT430	FT510	FT610
Spring Tine Rake				
Verti-Cutters	 <p>Ideal for lifting lateral growth, helping to stand grasses up, removing dead matter or broken leaves. Helps to break up algae crust or help remove the glutinous slime that can sometimes appear on fine turf.</p>	TBC	TBC	15.2
	 <p>1mm thick 10 fingered replaceable discs. Regular use controls, thatch, lateral growth and the ingress of unwanted species such as annual meadow grass. Encourages vertical growth and ground cover. Cuts vertically into plant growth and above the soil, typically 2–3mm. Do not use to cut soil or during extended dry spells/drought.</p>	TBC	14.0	TBC
	 <p>1mm thick 11 fingered replaceable discs. Tungsten tip gives extra durability for heavy usage. Regular use controls, thatch, lateral growth and the ingress of unwanted species such as annual meadow grass. Encourages vertical growth and ground cover. Cuts vertically into plant growth and above the soil, typically 2–3mm. Do not use to cut soil or during extended dry spells/drought.</p>	TBC	16.7	19.4
Sorrel Roller				
Non-Powered	 <p>Replaceable spikes relieves surface tension and allows penetration of air, water and fertilizer to the root zone. Good for over seeding and preparing damaged areas for repair.</p>	TBC	18.4	TBC
	 <p>Helps relieve surface tension and prevents thatch, penetrating deeper than a verti-cutter, into the soil layer.</p>	TBC	TBC	TBC

5. Operation and Emergency Procedures

5.1. Pre-Start and Safety Checks



DANGER - OPERATING RISKS

- Prior to using the machine, ensure you read and understand this Operator Manual carefully. Failure to do so may result in injury and damage to the machine.
- Moving parts can cause serious injury. Keep hands, feet and clothing clear of moving components, particularly the cylinder and rollers. Contact with moving parts will cause severe personal injury or amputation.
- Before turning the engine on, you *must* ensure the area is clear of people and obstacles, and all safety guards are present.
- Hearing protection must be worn prior and during use with the engine *on*.



WARNING - MAINTENANCE CHECKS

Before using the machine, ensure all maintenance checks are complete, as per "6.1. Maintenance Schedule" p.41.



WARNING - SAFE OPERATING ENVIRONMENT

Always assess the job prior to starting. See "5.8. Operating Environment" p.38 for further information.

5.2. Cutting Preparation





WARNING - CUTTING SAFETY

- *Always* turn the machine *off* before adjusting any part of the cylinder, shear blade or before removing/inserting a cassette. Failure to do so creates a very high risk of cutting or amputation. *Always* wear hand protection.
- The cassettes are heavy - "4.5. Cassettes" p.22 for more information. Some may require two people to remove/insert.

5.2.1. Removing and Inserting a Cassette

No tools are required for removing or inserting a cassette.

1. Turn the engine off.
2. Remove the grassbox and store to the side.
3. Loosen the cassette retaining pin (Fig. 8A) until the pip end is inside the nut on the side frame.
4. Slide the cassette along the tie-bars towards the R/H side of the machine. The L/H of the cassette will be clear of the three pins of the drive coupling (~15mm) (Fig. 8B).
5. From the front of the machine, hold onto the cassette handle and remove by a lift-and-swing motion, from the back to the front.  (Fig. 8C). We recommend two people to help with this for larger cassettes.
6. To insert a cassette: Lift the cassette using the handle and lower the front slots of the cassette unit onto the front bearing studs. Slowly lower the back end onto the back tie-bars.
7. Slide the cassette to the L/H of the machine until there is full engagement with the three pins of the drive coupling (Fig. 8D). The cylinder may need slight manual rotation to align with the pins. 
8. Tighten the cassette retaining pin (Fig. 8E).
9. Normal use can now be resumed.

5. Operation and Emergency Procedures

Fig.8. Removing and Inserting a Cassette

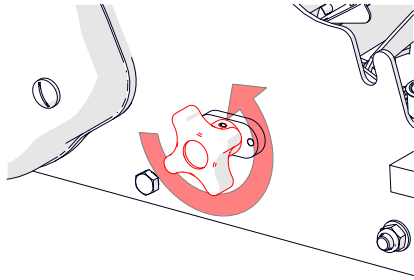

Fig.8A - Unscrew retaining pin.

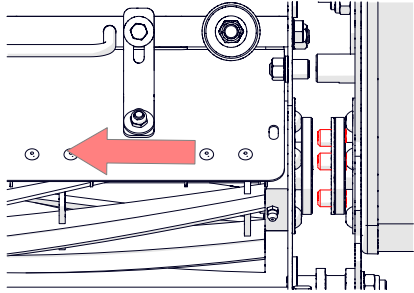

Fig.8B - Slide cassette until pins are visible.

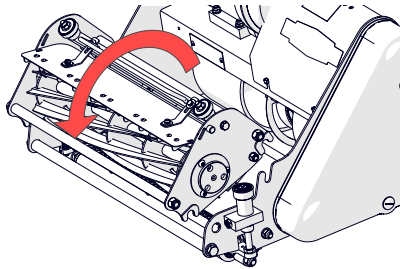

Fig.8C - Lift the cassette out.

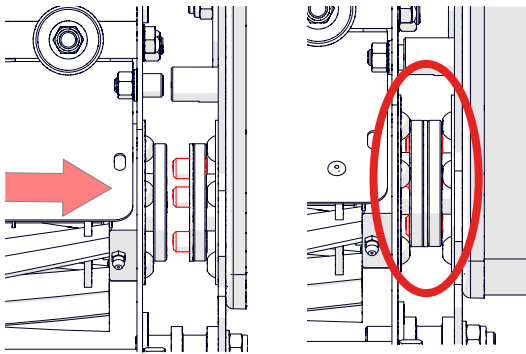

Fig.8D - Lower the new cassette in and slide across, engaging with three pins.

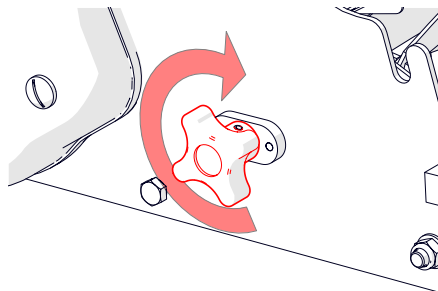

Fig.8E - Secure the locknut.

5.2.2. Adjusting Height (Cutting)

Cut height is adjusted using the supplied setting bar and basic tools.



NOTE - HEIGHT OF CUT

- When adjusting both the height of cut and the shear blade setting, always set the shear blade **first** before modifying the height of cut. Doing the opposite way may result in a different height of cut than planned.
- Remember height of cut is affected by moisture of turf, weight of the machine and thatch density. It is advised to set the height a little higher than your preference and reduce height by trial.

The following procedure is for adjusting the height of cut for the cylinder cassettes only. For other cassettes, see "5.2.3. Adjusting Height (Scarification, Dethatching and Brushing)" p.28.

Tools required:

- 19mm spanner
- Rule
- Setting bar

1. Turn the engine off.
2. Remove the grassbox and store to the side.
3. On the setting bar, adjust the bolt against the rule until the distance between the base of the bolt head and rule is that of the desired grass length. Secure with the nut [19mm spanner] (Fig. 9A).
4. Tip the machine gently back so it rests on the rear roller and handlebar (Fig. 9B).
5. Two positions along the cassette are required to be measured and adjusted to result in an even cut. Choosing either end of the cassette first, lay the setting bar across the front and rear roller. Correct height is achieved when the underside of the bolt head rests, or is level with, the lip of the

5. Operation and Emergency Procedures

shear blade (Fig. 9C). If it already is, then no further adjustment is needed. If not, then continue with step 6.

6. **FT models** - Manually turn the cut height adjuster to alter the height (Fig. 9D). It adjusts in quarter turn 'clicks' of 0.25mm increments. Therefore a full rotation of the adjuster raises or lowers by 1mm.

Clockwise = reduce height.
Anti-clockwise = increase height.

SuperSix models - Manually loosen the adjuster knob on each side to allow the quadrant mechanism to slide and alter front roller height (Fig. 9E).

While adjusting the height, position up the setting bar again between the front and rear roller. Stop adjusting when the head rests within the lip of the shear blade (Fig. 9F).

7. Repeat step 6 for the second position on the other side of the cassette.
8. Check the setting bar again for both sides. Adjust if necessary.
9. Lift the machine gently up to rest on its front and rear rollers. Return the grass box.
10. Normal use can now be resumed.

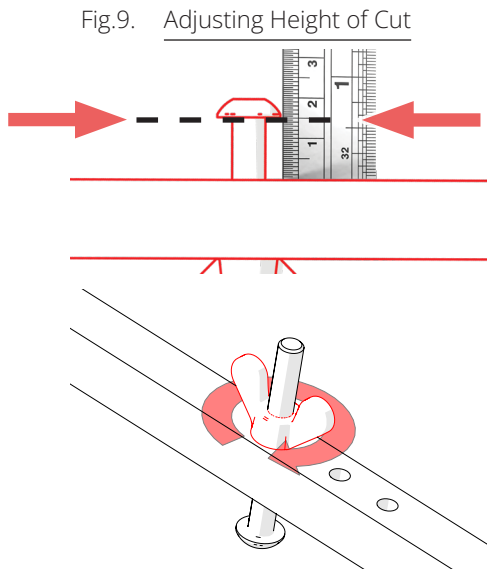

Fig.9A - Adjust bolt to desired cut height and secure nut (above example set for 15mm).

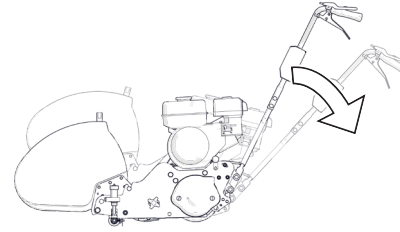

Fig.9B - Gently tip the machine back.

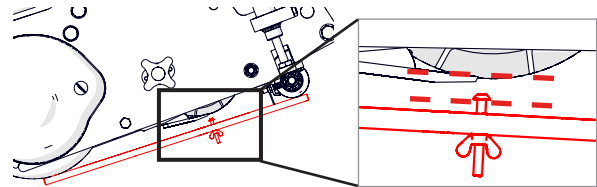

Fig.9C - Position the setting bar and observe distance between the top of the shear blade and bottom on the bolt head. In this example, the bolt head is below the shear blade, indicating the machine cut height is currently too high and therefore needs lowering.

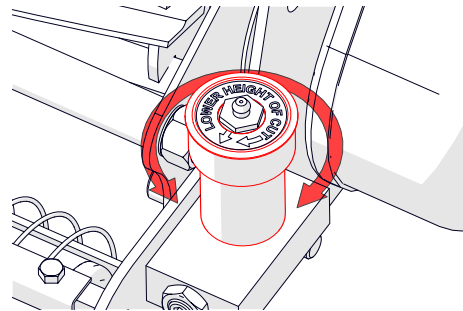

Fig.9D - Adjust the cut height adjuster (FT).

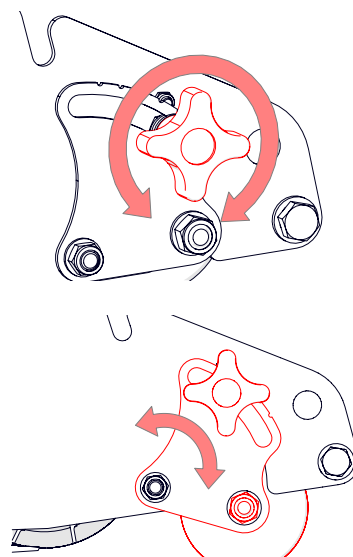

Fig.9E - Adjust the cut height adjuster (SuperSix).

5. Operation and Emergency Procedures

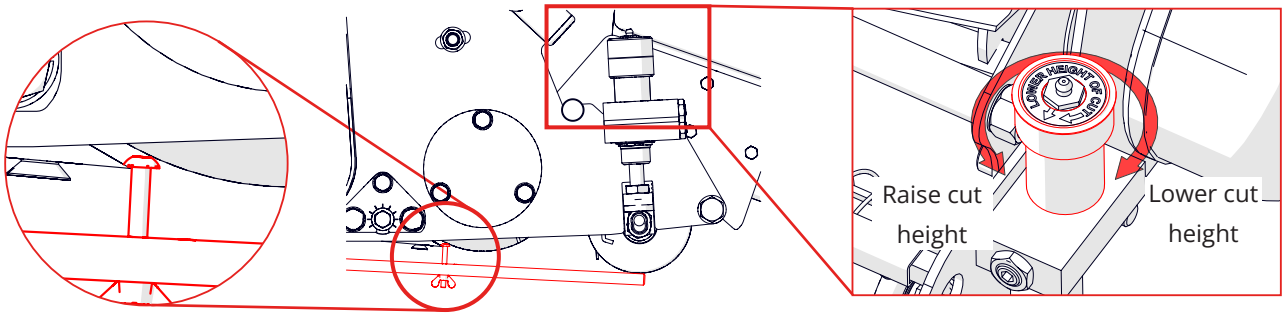

Fig.9F - Rotate the cut height adjuster while offering up the setting bar. Stop when the head rests level/within the shear blade

5.2.3. Adjusting Height (Scarification, Dethatching and Brushing)

The following procedure is for adjusting the height of cut for the scarifying, dethatching and brushing cassettes. For cylinder cassettes, see "5.2.2. Adjusting Height (Cutting)" p.26.

Tools required:

- 19mm spanner
- Rule
- Setting bar

1. Turn the machine off.
2. Remove the grassbox and store to the side.
3. On the setting bar, adjust the bolt against the rule until the distance above or below the setting bar (to the head or end, respectively) is to that desired (Fig. 10). To note:

- Brush/Verti-cutter/Spring-tine rake = Measure from top side of setting bar **up**.
- Scarifier/Sorrel roller = Measure from top side of setting bar **down**.

Secure the bolt height with the nut [19mm spanner].

4. Tip the machine gently back so it rests on the rear roller and handlebar (Fig. 9B).
5. Two positions along the cassette are required to be measured and adjusted to result in an even brush/verti-cut/scarify. Choosing either end of the cassette first,

lay the setting bar across the front and rear roller (Fig. 9C). Correct height is achieved when either the tips of the brush hairs/verti-cutters are level with the bolt head, or the tips of the scarifier/sorrel roller are level with the bolt end. If it already is, then no further adjustment is needed. If not, then continue with step 6.

6. Manually turn the cut height adjuster to alter the height (Fig. 9D). It adjusts in quarter turn 'clicks' of 0.25mm increments. Therefore a full rotation of the adjuster raises or lowers by 1mm.

Clockwise = reduce height.

Anti-clockwise = increase height.

While adjusting the height, position up the setting bar again between the front and rear roller. Stop adjusting when either the tips of the brush hairs/verti-cutters are level with the bolt head, or the tips of the scarifier/sorrel roller are level with the bolt end. (Fig. 10).

7. Repeat step 6 for the second position on the other side of the cassette (Fig. 9E).
8. Check the setting bar again for both sides. Adjust if necessary.
9. Lift the machine gently up to rest on its front and rear rollers. Return the grass box.
10. Normal use can now be resumed.

5. Operation and Emergency Procedures

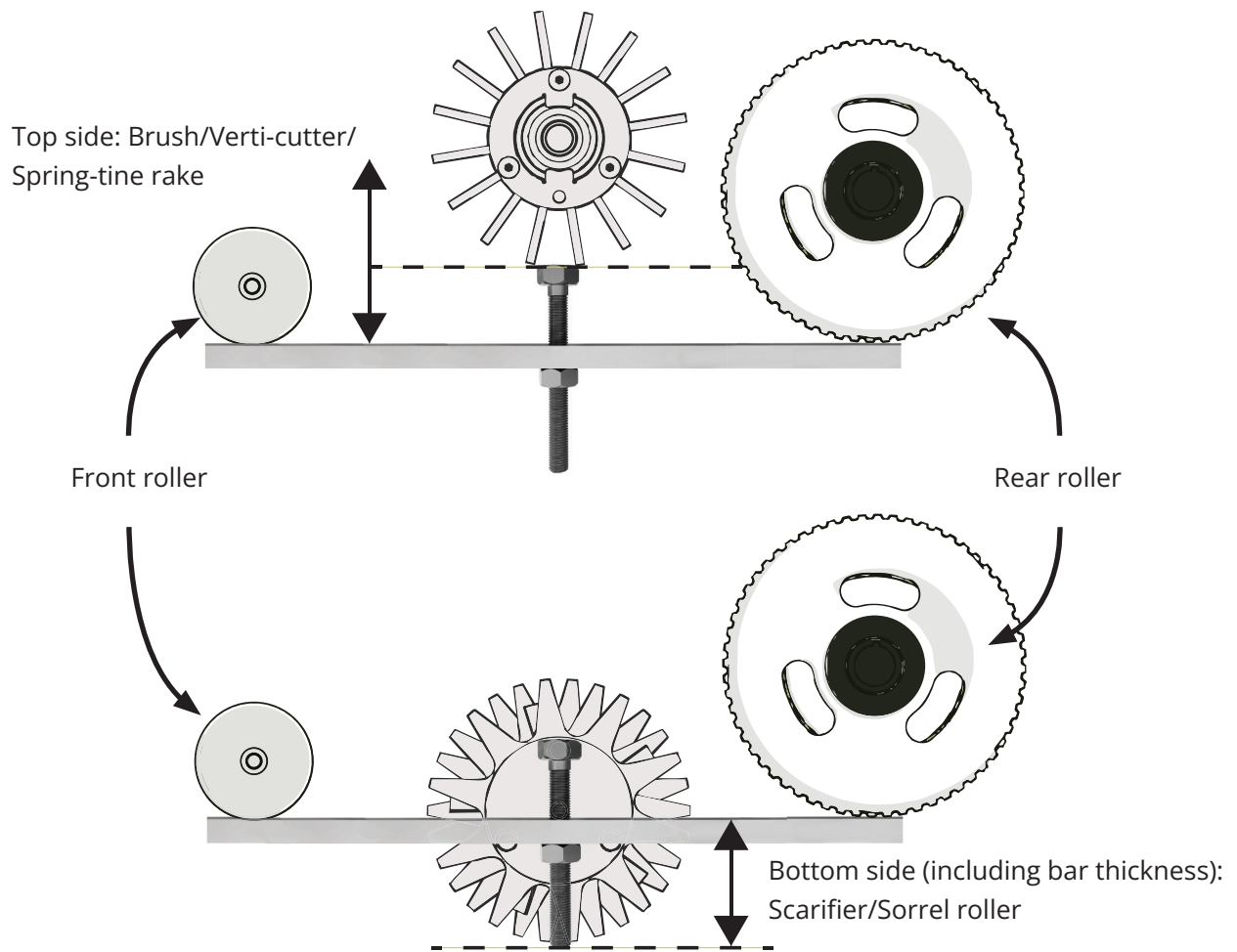

Fig.10. Setting bar measurement for above/below ground cassettes.

5. Operation and Emergency Procedures

5.2.4. Handlebar Height Adjustment

Tools required:

- 13mm spanner
 - 19mm spanner
1. Turn the machine **off**.
 2. Choosing either side of the machine, locate the upper nut at the bottom of handlebar and loosen [13mm spanner] (Fig. 11A & 11B). Secure the pivot bolt while doing so [19mm spanner].
 3. Repeat with the other side.
 4. Remove the pivot bolt, washer and nut. Adjust the handlebar to the desired height, using one of the three adjustment holes and reinsert fixings.
 5. When set, tighten both sides sufficiently [13mm and 19mm spanner].

Fig.11. Handlebar adjustment

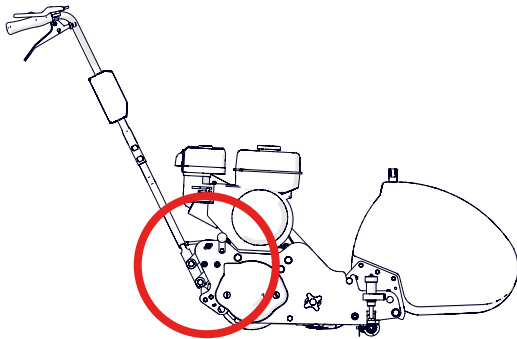

Fig.11A - Handlebar adjustment location.

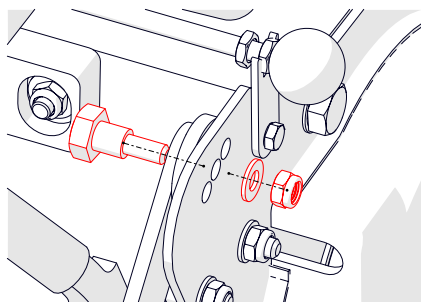

Fig.11B - Loosening the nut and bolt.

5.2.5. Shear Blade Adjustment



CAUTION - RISK OF INJURY

- *Always* turn the machine **off** before commencing this task.
- *Always* wear protective gloves to reduce risk of cuts and finger trapping.



NOTE - ORDER OF ADJUSTMENT

If planning on adjusting the height of cut at the same time, always adjust the shear blade first then adjust the height of cut. Doing the opposite way may result in a different height of cut.

Tools required:

- Scrap paper
 - 9/16" spanner
1. Turn the machine **off** and disengage the cassette clutch rod.
 2. Remove the grassbox and store to the side.
 3. Tip the machine gently back so it rests on the rear roller and handlebar (Fig. 12A). Chock the rear roller to stop unintended rolling.
 4. Choosing the left or right hand side of the cassette, test the cut by moving the cassette blade with a gloved hand and using a piece of paper between the cassette and shear blade (Fig. 12B). If it does not cut the paper, or does not cut cleanly, then adjustment of the shear blade is required - see step 5. If it does cut cleanly, repeat test on the other side before proceeding to step 5 if required.
 5. Located at each end of a cassette are two shear blade adjusters. On the side being adjusted, loosen the lock nut [9/16" spanner] (Fig. 12C).
 6. Manually alter the gap with the adjustment knob (Fig. 12D). Only very small adjustments

5. Operation and Emergency Procedures

are required - start with $\frac{1}{8}$ of a turn and repeat the paper cut test. Repeat adjustment until the paper cuts cleanly.



NOTE - ADJUSTMENT DIRECTION

A sticker next to the adjuster informs of direction:

- ON = Decrease gap (i.e. cut 'on'),
- OFF = Increase gap (i.e. cut 'off').

7. Secure the lock nut.
8. Repeat step 6 on the opposite side.
9. Repeat the paper cut test on both sides. Adjust where necessary. Tighten the lock nuts.
10. Lift the machine gently up to rest on its front and rear rollers. Return the grassbox.
11. The machine is now ready for use.

Fig.12. Shearblade adjustment

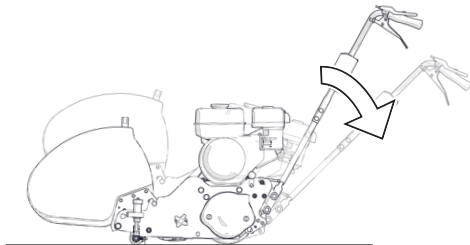

Fig.12A - Tip to rest of handlebars

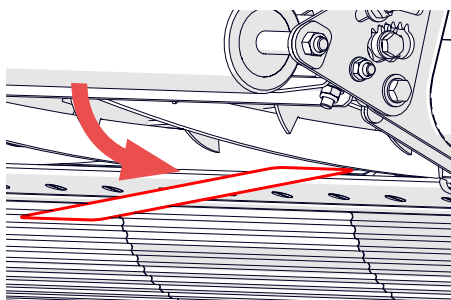

Fig.12B - Repeating adjustment for other side

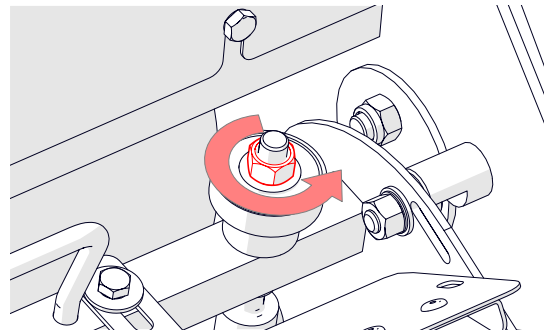

Fig. 12C - Loosen the lock nut

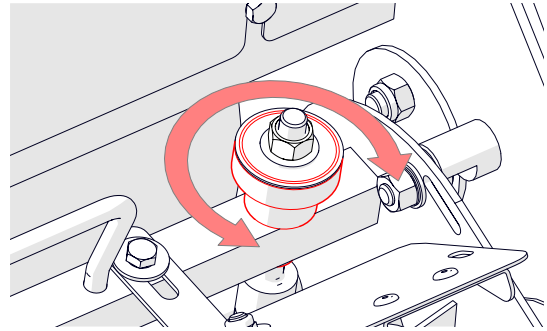

Fig.12D - Tighten/loosen the adjustment nut

5. Operation and Emergency Procedures

5.3. Engine

5.3.1. Safety Information



WARNING - ENGINE SAFETY

- **Always** read the safety instructions in "2.3.2. Engine and Fuel Safety Instructions" p.7
- This manual includes general guidance for the operation and maintenance of the engine. Always read the OEM engine 'Owner's Manual' provided for specific instructions and safety information not covered in this manual.
- Allow the engine to idle for a short time before driving, especially in cold weather.

5.3.2. Refuelling



WARNING - REFUELLING

Note the following for correct and safe refuelling use:

- Turn off the engine and allow it to cool before refuelling.
- Avoid smoking or using any ignition sources near the refuelling area.
- Refuel outdoors or in a well ventilated area.
- Only refuel using unleaded petrol (pump octane rating 86 or higher).
- Fill to no further than the neck of the tank.

5.3.3. Installation and Removal

The engine is supplied mounted to the chassis on engine bearers. During normal use, there is no expectation to remove the engine. However, if the engine is required to be removed entirely:

1. Turn the machine **off** from both the start switch (located with the control components)

and the engine on/off switch.

2. If the engine is being removed permanently, remove all fuel and oil with a syphon pump or similar. If the engine is being removed temporarily, ensure the fuel cap and oil plug are secure.
3. Remove the 4 x M8 hex bolts securing the engine to the engine bearings [13 mm spanner].
4. Slide the engine towards the right hand side of the machine - this will disconnect the engine coupling from the driveshaft.

5.3.4. Engine Specifications

For engine specification, see "4.1.2. Specification Table" p.14 and within the supplied OEM manual for the engine.

5.3.5. Replacement and Disposal

Should the engine require disposal, follow the points in "6.6. Disposal" p.52.

5. Operation and Emergency Procedures

5.4. Starting the Engine

To turn your engine *on*:

1. Engage the parking brake (Fig. 13A).
2. Set the engine switch (located on the engine) to the *on* position (Fig. 13B).
3. Set the fuel lever to the *open* position (Fig. 13C).
4. Set the choke lever to the *closed* position (Fig. 13D). Note, setting the choke to this position is not required if the engine is warm or the air temperature is high.
5. Set the throttle lever to the *tortoise* position (Fig. 13E).
6. Grasp the starter grip handle and extend until the slack is removed. At this point, pull with a steady and fluid motion (Fig. 13F). The engine will start.
7. Allow the starter grip handle to return gently, avoid releasing it to 'snap' back into position.
8. Gradually move the choke lever into the *open* position (towards the front) (Fig. 13G). Leave to warm up for 3-5 minutes.

Fig.13. Power on procedure

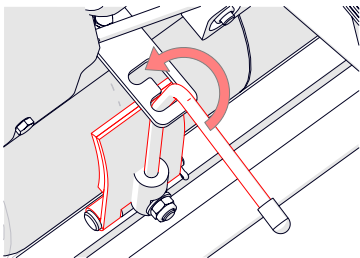

Fig.13A - Parking brake on.



Fig.13B - Engine switch on.

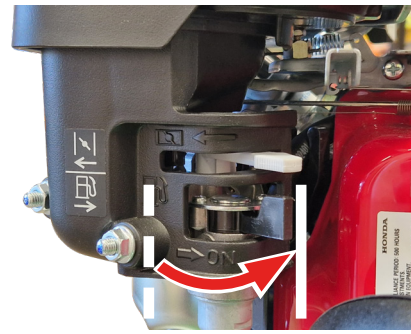

Fig.13C - Fuel lever open.

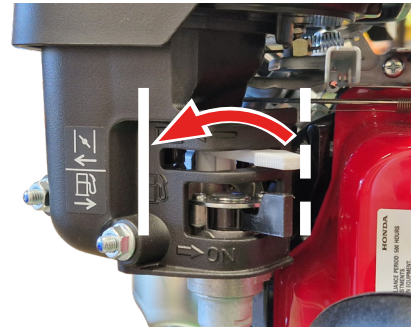

Fig.13D - Choke lever closed.

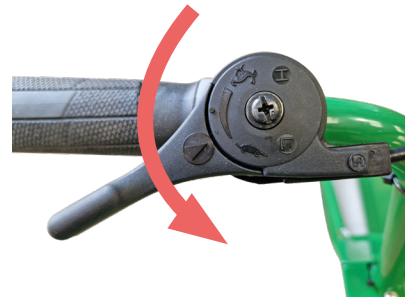

Fig.13E - Set throttle to tortoise.



Fig.13F - Pull starter grip handle.

5. Operation and Emergency Procedures

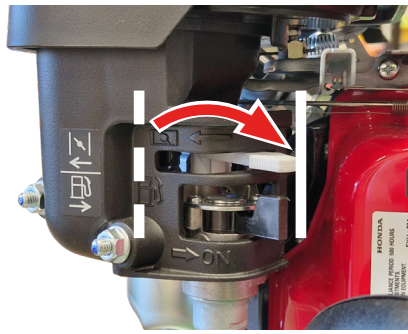

Fig.13G - Move choke lever into open position.

5.5. Stopping the Engine

Two methods are available to stop the engine:

- Increase the throttle lever fully to the *hare* position (Fig.14A) while ensuring nothing else is held or pressed. As a safety mechanism, the engine will automatically cease without the engagement of the OPC.
- Alternatively, decrease the throttle to the tortoise position and wait until engine revolutions have reduced and the centrifugal clutch drum has stopped rotating. Then from the front of the engine, set the engine switch to the *off* position (Fig.14B).

Fig.14. Power off procedure

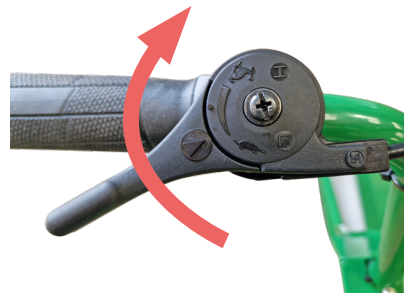

Fig.14A - Increase throttle to hare only.



Fig.14B - Alternatively, turn the engine to off.

5. Operation and Emergency Procedures

5.6. Drive

5.6.1. Moving and Transport (no cut)



CAUTION - HANDLEBAR HEIGHT

Prior to moving the machine, set handlebar to the correct height. See "5.2.4. Handlebar Height Adjustment" p.30.

1. Start the engine as per "5.4. Starting the Engine" p.33.
2. Release the parking brake (off position).
3. With one hand on each operating handle, depress the OPC with the right hand. Then with the left hand, **slowly** increase the throttle from idle until the centrifugal clutch drum starts spinning (this occurs approximately from the halfway position and will depend on engine size, temperature and other factors). If the drum does not start spinning, increase the throttle further.
4. With the right hand, slowly squeeze the drive/speed lever while keeping the OPC depressed. The machine will slowly start moving forward.
5. Squeeze or release the drive/speed lever to go faster or slower, respectively. If it is still too slow or feels like it is about to stall, increase the throttle.
6. To **stop** drive **temporarily**, release the drive/speed lever only. Releasing the OPC at this point will cut-out the engine and would require restarting. To **idle**, turn the throttle **down** to tortoise first and then release the OPC.



NOTE - ENGINE STOP

Depressing the OPC while in low engine speed (i.e. tortoise) will result in the engine stopping. Ensure engine speed/'revs' are sufficiently high before trying to move.



NOTE - DRIVING OVER HARD GROUND

When travelling over surfaces other than grass, tilt the machine backward to elevate the front roller, ensuring it travels solely on its rear roller. This avoids potential damage to the cassette and blades.

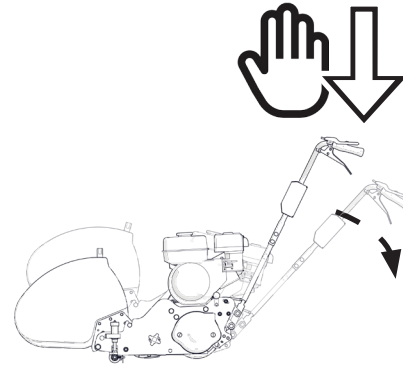

Fig.15. Driving procedure

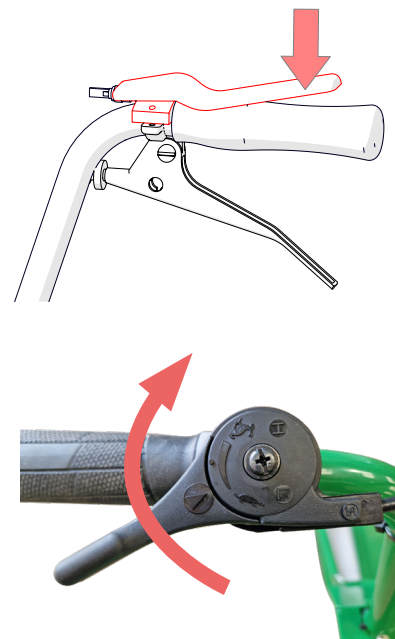

Fig.15A - Depress OPC and increase the throttle.

5. Operation and Emergency Procedures

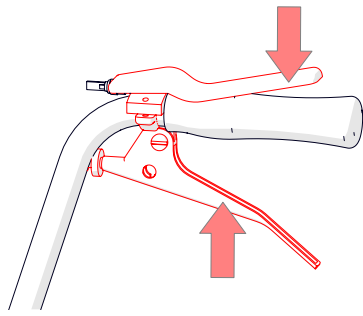

Fig.15B - While depressing OPC, squeeze drive/speed lever.

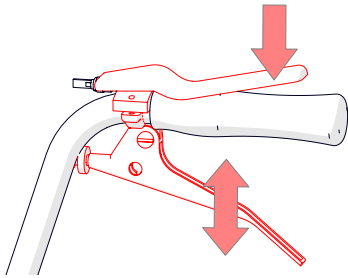

Fig.15C - While depressing OPC, squeeze or release drive/speed lever to adjust machine speed.

5.6.2. Operating on Slopes



WARNING - SLOPES

The machine operates best on flat ground. Follow the safety points below when operating on slopes:

- Slopes can tip a machine over. Observe extreme caution. Check for obstacles or anything that may lead to instability (e.g. dips, bumps, uneven ground) prior to operating.
- There is no maximum operating machine slope angle; use personal judgement, taking into account surrounding environment and weather. If in any doubt, do not use on a slope.
- Operate across the face of a slope, never up and down.
- Avoid when wet as this can increase the risk of an accident occurring.
- Go slow; speed can increase the risk of an accident occurring. Take extra care when turning.

5.7. Cutting

5.7.1. Moving and Cutting (including scarify/brush)



WARNING - ROTATING BLADES AND MOVING PARTS

- Blades, brushes and rollers can continue to rotate even after the motor has stopped.
- Never lift or carry a machine whilst any parts are moving.
- Always wait for the cylinder to stop rotating before travelling over anything that is not grass.
- Never carry out adjustments whilst the machine is running.



NOTE - HEIGHT OF CUT

Prior to cutting, set the cassette to the correct height. See "5.2.2. Adjusting Height (Cutting)" p.26.

1. Start the engine as per "5.4. Starting the Engine" p.33.
2. Release the parking brake (off position).
3. Lift and pull the clutch rod slightly so it is in the engaged state (Fig. 16A). Alternatively, the nut can rest on the rod stop plate (Fig. 16B) and it will drop into the engaged position once throttle is increased.
4. With one hand on each operating handle, depress the OPC with the right hand. Then with the left hand, *slowly* increase the throttle from idle until the centrifugal clutch drum starts spinning (this occurs approximately from the halfway position and will depend on engine size, temperature and other factors). When the drum starts spinning the cassette will spin too (the clutch rod will fall into the engage position if left on the stop plate).
5. Increase the throttle to full. With the right hand, slowly squeeze the drive/speed lever

5. Operation and Emergency Procedures

while keeping the OPC depressed. The machine will start moving forward.

6. Squeeze or release the drive/speed lever to go faster or slower, respectively. If it is too fast even with light pressure on the drive/speed lever, reduce the throttle slightly, ensuring the engine speed is still enough to spin the drum.
7. To **stop** drive **temporarily**, release the drive/speed lever only. Releasing the OPC at this point will cut-out the engine and would require restarting. To **idle**, turn the throttle **down** fully and then release the OPC. This will also stop the cassette.
8. To resume, depress the OPC and increase the throttle and the cassette will start spinning.
9. To **stop** drive **completely**, see "**5.5. Stopping the Engine**" p.34.

Fig.16. Cutting procedure

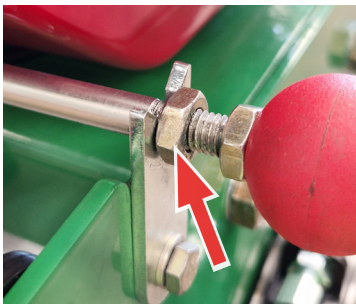

Fig.16A - Clutch rod in the engaged position.

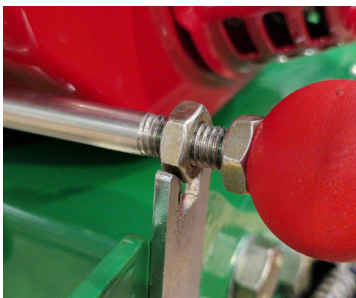

Fig.16B - Clutch rod nut resting on the rod stop plate.

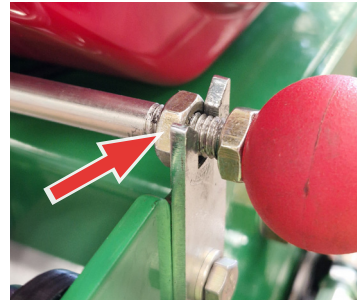

Fig.16C - Clutch rod in the disengaged position.

5.7.2. Cutting Technique

There is no set technique for cutting as it will suit individual circumstances. However we recommend the following:

- Mow in straight lines - turning while cutting may damage the turf and produce an inferior quality of cut.
- To perform a turn, press the handlebar down to lift the front of the machine before applying force to the left/right side. The three part differential rear roller allows for easier and tighter turning.
- Mow at a standard walking space - alter the throttle speed accordingly to achieve this.
- Do not cut for too long in a single spot or without cutting grass. This can damage the grass and increase blade wear.
- Avoid cutting more than one third of the grass blade. Doing so can increase the risk of disease and stress for the plant.

5. Operation and Emergency Procedures

5.8. Operating Environment



CAUTION - ENVIRONMENTAL CONDITIONS

Failure to observe the conditions listed below may result in a risk to the operator and damage to the machine.

Refer to the OEM engine 'Owner's Manual' for further information.

Temperature:

- Use between -20 to +40°C*. However usage in the upper and lower limits of this range will affect performance and engine life.
- Operators must take necessary precautions against temperature, such as sun protection and suitable clothing.

**The machine can operate beyond the temperature range optimum for grass cutting. Grass is best cut between 10-30°C.*

Weather:

- Use in dry conditions wherever possible. Do not use on excessively wet or frozen ground. This avoids damage to motor components and traction hazards caused from slippery grass.
- Cutting wet grass leads to poorer cut quality, clumping and reduced collection into the grass bag. This results in additional cleaning of the machine.
- Compaction of the soil is more likely with wet weather.
- Do not use in adverse weather conditions (e.g. storms, high wind, risk of lightning etc).
- Operators must take necessary precautions against the weather, such as sun protection and suitable clothing.

Terrain/Slope:

- Ensure the ground is firm and preferably dry. Soft or wet ground can cause manoeuvrability problems.
- There is no maximum slope angle, however use professional judgement when using on slopes (see "5.6.2. Operating on Slopes" p.35)
- Before use, check to ensure the terrain is free from obstacles and obstructions, including rocks, branches and debris.

Humidity:

- Use between 30–70% RH. High humidity can lead to rust and corrosion on metal parts, and to fungal diseases on the grass after cutting.
- Low humidity can lead to wilting and browning of the grass after cutting.

Dust and particulate:

- Avoid dusty or sandy conditions. Such environments can damage the machine and be hazardous to the operator.

Vibration and Shock:

- Keep vibration and shock to a minimum to avoid damage to machine components. This includes, bumps, pot holes and kerbs.
- Store the machine away from passing traffic and avoid transporting over rough ground - lower gently over kerbs or use alternative routes.

Lighting Conditions:

- Use the machine in good lighting conditions, either natural or artificial. This allows for the safe operation of the machine.

Safety Zones:

- Other than the operator, all other personnel must keep their distance from the machine during use. This must be maintained by the operator to keep the zone free.

5. Operation and Emergency Procedures

5.9. Emergency Procedures

5.9.1. In the Event of a Breakdown



WARNING - MACHINE BREAKDOWN

- Take full care and attention while investigating the cause of a fault. Where possible, wear suitable PPE including gloves and safety glasses.
- Never touch leaked materials, avoiding contact with skin and eyes. Rinse immediately with water and seek medical attention if necessary.
- Secure the working area with appropriate warning notices.
- In case of a petrol spill, clean it up immediately using appropriate absorbent materials.

Regular service and maintenance will prevent the majority of machine breakdowns. The below procedure outlines the immediate actions if the machine fails to function entirely. If the machine is not working as intended and a minor issue, refer to "**6.7. Troubleshooting & FAQ**" p.52.

In the event of a breakdown:

1. Turn the engine **off**.
2. Disconnect the spark plug by holding between the thumb and fore-finger and pulling away. This prevents accidental engine starting.
3. If possible, move the machine to a safe area where further investigation can be carried out. If the machine cannot be moved, clearly label it as 'faulty' and cordon around the machine to mitigate unauthorised personnel from accessing the machine.
4. If there are fuel leaks, immediately clean up and adsorb with appropriate materials.
5. Once in a safe area or in a serviceable state, inspect the machine for any obvious defects. Do not attempt repairs beyond basic troubleshooting unless qualified. Full repairs to be carried out by qualified service engineer

and documented accordingly.

6. If the source of the breakdown cannot be found, contact your Dealer or Howardson Group for further information.

5.9.2. Hazardous Substances and Fire



WARNING - HAZARDOUS SUBSTANCES

- Always operate and refuel the lawnmower outdoors or in well-ventilated areas - never operate the engine in enclosed spaces. Avoid inhaling exhaust fumes.
- Wear appropriate PPE, such as gloves and safety glasses, when handling petrol.
- Dispose of petrol and contaminated materials in accordance with local regulations.

When operating the lawnmower, the combustion of petrol in the engine produces several emissions that may be hazardous to health and the environment. This includes predominantly:

- Carbon Monoxide (CO): A toxic, odourless gas that can cause dizziness and headaches,
- Nitrogen Oxides (NO_x): Can irritate the respiratory system,
- Other emissions include Carbon Dioxide (CO₂), unburned hydrocarbons, particulate matter and Volatile Organic Compounds (VOCs).

Operating outdoors or in well ventilated area will reduce this risk.

5. Operation and Emergency Procedures



WARNING - HANDLING PETROL AND FIRE PREVENTION

Note the following when working and handling petrol:

- Always use approved containers for petrol storage.
 - Store petrol in a cool, well-ventilated area away from open flames or sparks.
 - Avoid overfilling the fuel tank to prevent spills.
 - Keep the area immediately around the engine and exhaust free of grass and debris to prevent fire hazards.
 - Regularly inspect the machine for fuel leaks. Repair any found immediately and prior to use.
-

In the event of a fire involving the machine or fuel:

- Stop the engine immediately (if safe to do so).
- Evacuate the area and ensure all persons are at a safe distance.
- Do not attempt to move the machine if it is on fire.
- Call Emergency Services if the fire cannot be quickly and safely controlled.
- Use a Class B fire extinguisher, which is designed for flammable liquids such as petrol.

Important: Only attempt to extinguish the fire if you are trained and it is safe to do so. Personal safety must always come first.

6. Maintenance and Service

6.1. Maintenance Schedule



WARNING - CORRECT MAINTENANCE

- Following the schedule set out below will prolong the life of your machine and deliver high performance.
- Failure to carry out these checks at the specified intervals will result in damage to your machine and possible injury to personnel. If you are unsure of anything, contact Dennis or your Dealer.
- Not servicing your machine correctly will invalidate your warranty. See "6.8. Warranty Policy" p.58 for more information.
- Always use genuine Dennis/Honda parts when servicing and replacement.

The following checks must be actioned as per date or running hours, whichever comes first. Ensure checks are performed in an appropriate area (such as a storage shed), and not on the playing surface due to risk of containments/ petrol/oil. Complete checks with the engine *off* and when following 'Post-use', check only when the engine has cooled.

Checks regarding the petrol engine must be in conjunction with the maintenance items in the OEM manual. Where maintenance intervals differ, always follow the more frequent schedule to ensure optimal performance and warranty compliance.

Service kits are available for the machine - see "Appendix B. Service Kit" p.54.

Maintenance and Safety Checks	Daily		Weekly 25hr	Monthly 100hr	6-monthly 600hr	Annually 1200hrs
	Pre-use	Post-use				
Engine						
Check engine oil level is between upper and lower limit.	•					
Check air filter for dirt or damage. Remove any debris.	•					
Check fuel level is enough for intended use (do no overfill past the neck). Clean all grass/debris around the neck first to avoid contaminating the fuel.	•					
Check condition of the entire engine (including driveshaft guards) following for signs of damage. Do not use if anything is damaged.	•	•				
Clean off all grass cuttings/debris from the entire engine using an air-hose, brush or similar. This includes: fuel tank, air filter, starter grip and exhaust. Failure to clean will increase fire risk.	•	•				
Measure engine speed with tachometer. Speed must be 2650 rpm (±50 rpm) at full throttle. Adjust accordingly (see 'Idle speed' in engine Owner's Manual).					•	

6. Maintenance and Service

Maintenance and Safety Checks	Daily		Weekly 25hr	Monthly 100hr	6-monthly 600hr	Annually 1200hrs
	Pre-use	Post-use				
Change engine oil (20 hours first change).	Refer to engine Owner's Manual					
Clean sediment cup.						
Check/clean spark plug.						
Remove air filter cover and clean debris from base of filter.						
Remove air filter cover and remove outer foam filter and wash in warm, soapy water. Ensure thoroughly dry before returning. Replace if damaged.						
Remove air filter cover and clean debris from around the paper filter by tapping several times on a hard surface. Replace if excessively dirty or damaged.						
Check/adjust valve clearance*.						
Clean fuel tank and strainer*.						
Check fuel line. Replace if necessary*.						
Cassette 						
Check the blades/discs spin freely, with no grinding or metal-on-metal contact noises (<i>always</i> turn the machine <i>off</i> first).	•	•				
Check for wear or damage of the blades/shear blades/discs (impact, dents, material cracking and excessive thinning). Replace where required.	•	•				
Check the retaining nut is tight and secures the cassette.	•	•				
Grease ¹ cylinder bearings (x2).		•				
Check the cassette can be removed and replaced easily.			•			
Check the three pins of the drive coupling engage with the cassette.			•			
Adjust the metal deflector.	<i>As required</i>					
Chassis						
Check all guards are fitted correctly.	•					
Visually check all fixings (secure and in place).	•					
Check the grass box is fitted correctly.	•					
Check the cutting height is set correctly.	•					

6. Maintenance and Service

Maintenance and Safety Checks	Daily		Weekly 25hr	Monthly 100hr	6-monthly 600hr	Annually 1200hrs
	Pre-use	Post-use				
Clean off all grass cuttings from bodywork.		•				
 Clean off all grass cuttings from the cylinder blade (ensure the machine is turned off first. Use a long handled brush).		•				
Lubricate the dog clutch. See " 6.2.5. Oiling Dog Clutch " p.49			•			
Remove side drive guard and visually check condition of drive belts. Adjust/change if required.			•			
Grease ¹ rear roller bearings (x2).			•			
Grease ¹ height adjusters (2)			•			
Renew oil in rear roller ²					•	
Check rear roller bushes for wear and lateral movement.					•	
Lubricate front roller pivot bushes.					•	
Replace all drive belts.						•
Controls						
Check the following for signs of damage and that they operate freely and as intended: <ul style="list-style-type: none"> • OPC • Drive / speed levers • Throttle 	•					
Set the parking brake to on and check it secures the machine and the mechanism moves freely.	•					
Operate the OPC (engine off), ensure the 'click' is heard from its microswitch.	•					
Set the cassette rod to engage position and start engine. Tip the machine back slightly and depress OPC. Increase engine speed to maximum so cassette starts spinning. Release the OPC only - the cassette and engine must stop. If it does not, see " 6.7. Troubleshooting & FAQ " p.58.	•					

¹ See section "**6.2.8. Lubrication**" p.55

² See section "**6.2.7. Changing Rear Roller Oil**" p.54

*Authorised Honda dealer or mechanically proficient only.

6. Maintenance and Service

6.2. Servicing Instructions



WARNING - SAFETY

- You **must** turn the machine **off** before service work. Failure to do so may cause major injury.
- Always wear suitable PPE for the job at hand.



CAUTION - SERVICE LOCATION

When servicing the machine, position in a suitable environment for working on (for oil spills etc) and if planning leaving for extended periods.

6.2.1. Cassette and Drive Belt Replacement/ Tensioning



CAUTION - BELT TENSIONING

Incorrect tensioning of a belt can lead to a range of issues and premature failure of components. Issues include slippage (resulting in poor power transmission), increased component wear, increased noise, increased stress on bearings and pulleys, pulley damage and many others.

New belts will stretch during the first hours of use and must be monitored regularly. Inspect after ~30 minutes to four hours operating under full load and re-tension accordingly.

After approximately 24 hours of operation, inspect and re-tension again.

Tools required:

- Slotted screwdriver
- 10mm spanner
- 13mm spanner
- 9/16" spanner
- Replacement belt (*if required, cassette belt p/n J209005, drive belt p/n J209003*)

1. Turn the machine **off** and disengage the cassette clutch rod.
2. Remove 2 x outer screws of the side drive guard [slotted screwdriver] (Fig. 17A) and keep to the side.
3. Remove 4 x hex screws of the top drive cover [10mm spanner] (Fig. 17B) and keep to the side.
4. Loosen the rear roller tensioner pulley [13mm spanner] (Fig. 17C).
5. For the rear roller belt (skip to step 6 for cassette belt):
 - i. Hold the rear roller tensioner pulley away. Remove the belt and replace (if required) (Fig. 17D).
 - ii. Engage the rear roller tensioner pulley to the belt and apply light pressure. Tighten its nut securely [13mm spanner].
6. Cassette belt:
 - i. Hold the rear roller tensioner pulley away. Remove the rear roller belt (Fig. 17D).
 - ii. Loosen the cassette tensioner pulley from its backplate [9/16" spanner] (Fig. 17C).
 - iii. Hold the cassette tensioner pulley away. Remove the belt and replace (Fig. 17D).
 - iv. Adjust the tensioner pulley to add tension to the belt and tighten. Tension is tested by twisting the belt between thumb and forefinger. Achieve a twist between 70–90° (Fig. 17I). Re-adjust the tensioner pulley if necessary, making more or less contact to achieve these values. Tension may also change based on age of the machine and belt wear (if re-adjusting).
 - v. Refit/replace rear roller belt - see step 5.
7. Secure 4 x hex screws of the top drive cover [10mm spanner] (Fig. 17B).

6. Maintenance and Service

- 8. Secure 2 x outer screws of the side drive guard [slotted screwdriver] (Fig. 14A).
- 9. The machine is now ready for use.

Fig.17. Drive belt replacement / tensioning

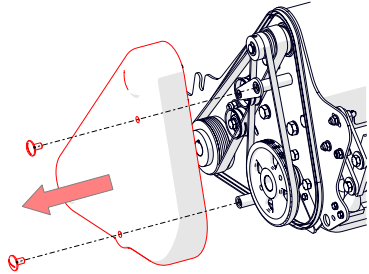

Fig.17A - Remove 3 x outer screws and cover.

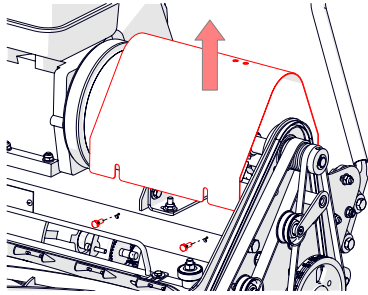

Fig.17B - Remove the top drive cover screws and remove cover.

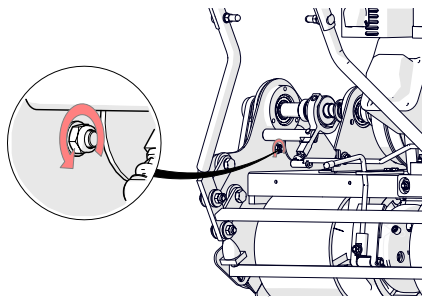

Fig.17C - Loosen rear roller tensioner pulley.

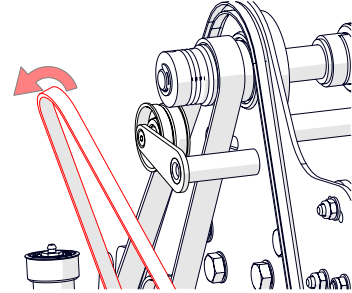
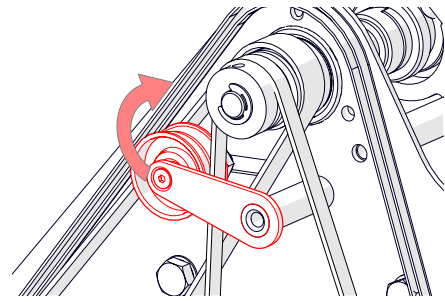

Fig.17D - Move the rear roller tensioner away and remove/replace the belt.

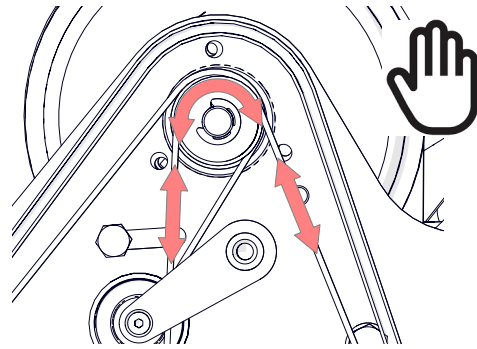

Fig.17F - Check correct tension by moving the pulley by hand.

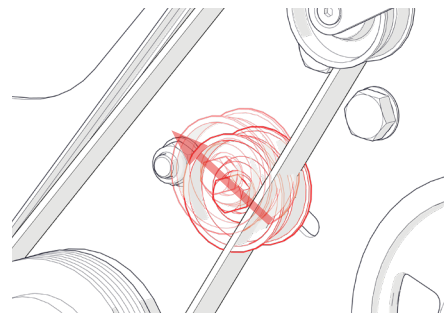

Fig.17G - Loosen the tensioner pulley.

6. Maintenance and Service

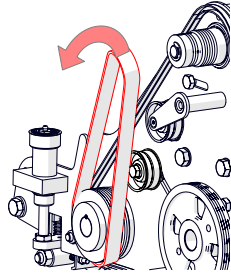

Fig.17H - Remove and replace the belt.

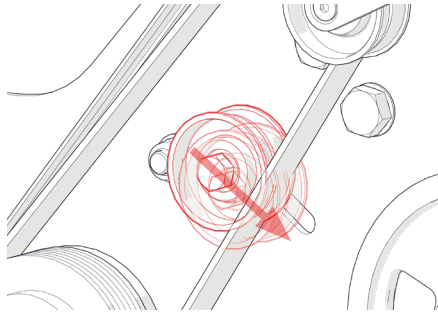

Fig.17I - Adjust the pulley to add pressure to the belt.



Fig.17J - Correct pressure achieved when the belt twists 90°.

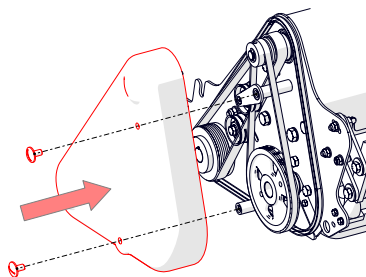

Fig.17K - Reattach cover.

6.2.2. Backlapping

Cutting blades will become blunt over time, producing an inferior quality of cut. Backlapping is the method of sharpening both the cylinder and shear blade simultaneously using a grinding compound while manually running the drive in reverse. This maintains a sharp edge on the blades to prolong their life, however it is not a substitute for a true grind. Do **not** backlap on damage blades or those beyond repair.

Grinding paste is required to achieve the sharpening of the blades. Three grit types are commonly available (80/120/220 grit) - the type chosen should be based on blade number, wear and expected use.



WARNING - BACKLAPPING

- **Always** wear suitable PPE, including eye protection and gloves.
- **Always** use a long handled brush. This minimises risk of close contact with the spinning cylinder.
- Backlap in a suitable area where the paste can be washed away afterwards. The paste can splatter so ensure a distance is maintained around the machine.

Tools required:

- Long handled brush
 - Back lapping paste
 - Backlap drive adaptor (p/n 229571)
 - Speed brace /drill (1/2" drive)
1. Turn the machine **off**. Remove the cassette from machine (see "**5.2.1. Removing and Inserting a Cassette**" p.25).
 2. On a level surface, place the cassette on its back, with the shear blade pointing upwards.
 3. Apply a small amount of grinding paste

6. Maintenance and Service

along the whole length of each blade using a long handled brush (Fig. 18A).

4. Insert the backlap drive adaptor into the cassette drive coupling.
5. Using a suitable brace or drill, rotate the cylinder clockwise causing a grinding action with the shear blade (Fig. 18B). This should be continued until a sharp lip is achieved on the leading edge of each cylinder blade. This may take a few minutes - stop periodically to check the edge and reapply paste as necessary.

Note: rotating the cylinder clockwise is opposite to the normal operation of the machine. This may cause the drive coupling to become unscrewed. If this occurs, chock the cylinder with a piece of wood or similar, and tighten the drive coupling [Left hand thread].

6. When backlapping is complete, all grinding paste must be cleaned off the cylinder. This can be achieved with a low powered hose or a sponge and bucket of water. Failure to clean thoroughly will result in accelerated wear while cutting.
7. Return the cassette to the machine. The machine will now need the shear blade adjusting to account for the change to the cylinder, "**5.2.5. Shear Blade Adjustment**" p.30.

Fig.18. Backlapping

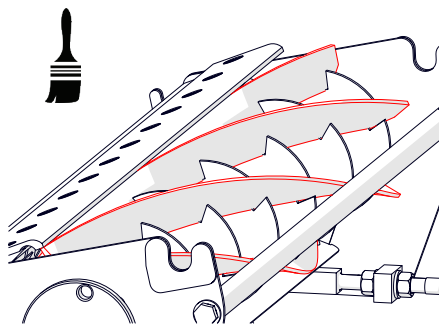

Fig.18A - Apply paste to the blades

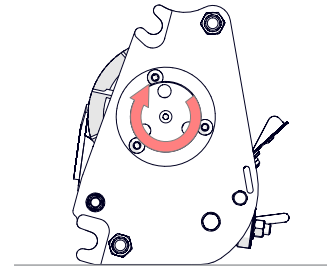

Fig.18B - Rotate the cylinder clockwise

6.2.3. Grinding Cutting Blades

Grinding, as with backlapping, restores the sharp edge of the blades, allowing for a clean, precise cut. Grinding is highly recommended to maintain optimal performance and extend the life of the cutting cassette. However unlike backlapping, this method creates an 'as new' sharp edge, rather than a temporary honed one.

Grinding is recommended when paper does not cut cleanly from the shear blade test (see "**5.2.5. Shear Blade Adjustment**" p.30), or when backlapping does not achieve the sharp edge required (usually caused by the edge being rounded too far beyond the capabilities of backlapping). Grinding can also help restore the cylindrical shape of the cylinder, which without, would be seen in poor grass cutting quality and streak marks.

Two grinding methods are performed on our cutting cylinders - spin and relief. As standard, all Dennis cutting cylinders are spun ground, with those of eight blades or more having an additional relief grind. Relief grinding is the process of removing material from the back of each cylinder blade to create a slight angle (i.e. the 'relief').

This relief angle produces a number of benefits:

- Improved cutting quality.
- Increased efficiency: Relief ground cylinders have been shown to reduce the power required to achieve a cut, thereby reducing fuel consumption. This is achieved from

6. Maintenance and Service

less friction between the cylinder and shear blade.

- Less wear between the cylinder and shear blade resulting in:
 - i. Longer blade life for both cylinder and shear blades.
 - ii. Less cylinder/shear blade adjustments.
 - iii. Less backlapping maintenance.
- Longer service life of adjacent moving parts, such as bearings and gears.

Factory standard relief grind is 50% land area at 30 degrees (see Fig. 19). It is recommended to grind to these values.

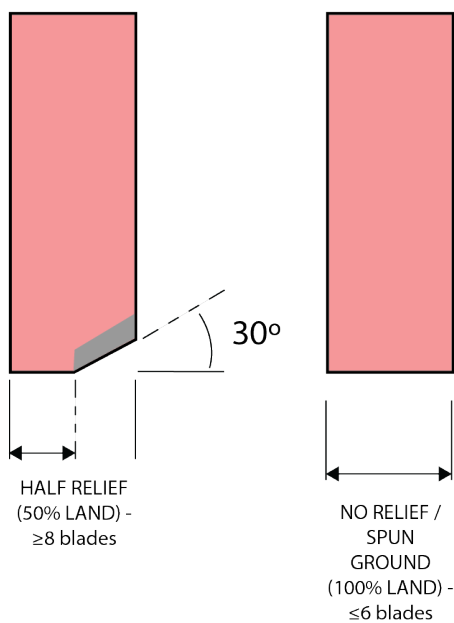

Fig.19. Recommended cylinder grind angle

Shear blades also need to be ground, ideally at the same time as the cutting cylinder. It is important to include a relief grind as this helps present the grass at the correct height for cutting. Without this, using a flat or positive front angle can lead to inconsistent cutting heights and an uneven grass surface (see Fig. 21).

Factory standard is a front angle of -10° and top angle of -2° , as shown in Fig. 20.

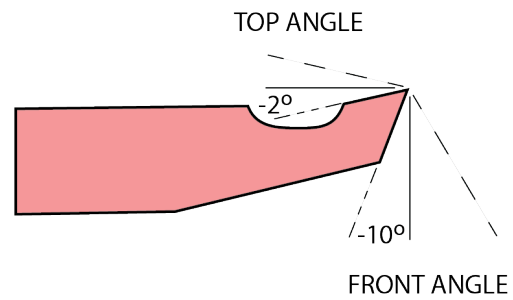
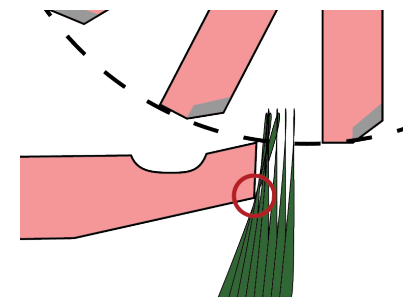
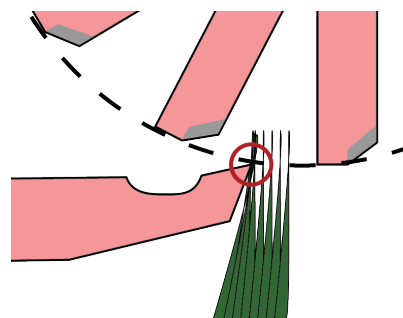

Fig.20. Recommended shear blade grind angle



Flat front angle and too early contact.



Negative front angle and correct contact point.

Fig.21. Illustration of two different shear blade angles and their grass contact point

For any method of grind, you must use a professional grinding service or dedicated grinding machine. Fail to do this may result in a far inferior cut and increased risk of injury.

6. Maintenance and Service

6.2.4. Changing Rear Roller Oil

To replace the oil in the rear roller:

Tools required:

- Lifting jack, raised platform or another method to raise the machine
- Wooden chocks
- 1/4" or 6mm hex socket
- Oil tray (volume >0.5L)
- Oil absorbent pads
- Oil (grade EP90) - 100ml
- Oil funnel and tube, or similar

1. Turn the machine **off** and allow the engine to cool.
2. Chock the front rollers. Lift the rear of the machine enough to gain clearance for 8mm hex socket and oil tray.
3. Place oil absorbent pads down under the roller along with an oil tray.
4. Rotate the central roller until the drain hole is pointing upwards, between the brake and chassis (Fig. 22A & Fig. 22B).
5. Remove the tapered plug [1/4" hex socket]. Rotate the roller down and let the oil drain.
6. Once fully drained, rotate the roller upwards again, between the brake and chassis.
7. Fill the roller with the correct grade and quantity of oil using the funnel/tube or similar.
8. Insert the tapered plug. Remove the oil absorbent pads and trays and dispose of in a responsible manner.
9. Lower the machine. The machine is now ready for use.

Fig.22. Rear roller oil

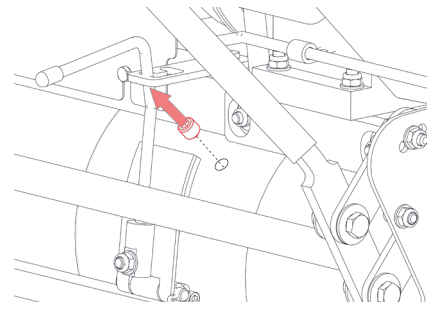

Fig.22A - Rotate central roller.

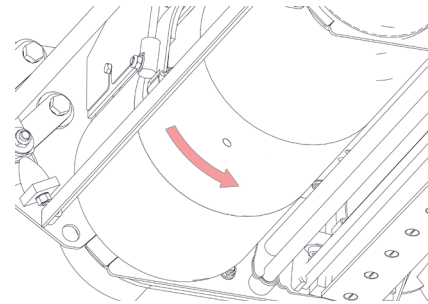

Fig.22B - Rotate roller so drain hole points downwards and oil drains.

6.2.5. Oiling Dog Clutch

The dog clutch transfers power from the centrifugal clutch drum to the cassette and rear roller pulleys. It is used via the cassette clutch rod and requires periodic oiling to prevent engagement issues. For operator convenience, two holes are located in the guard to provide direct access to oil the clutch. Apply 2-3 drops of multi-purpose oil (e.g. 3-in-one) in each hole according the schedule set out in "6.1. Maintenance Schedule" p.41.

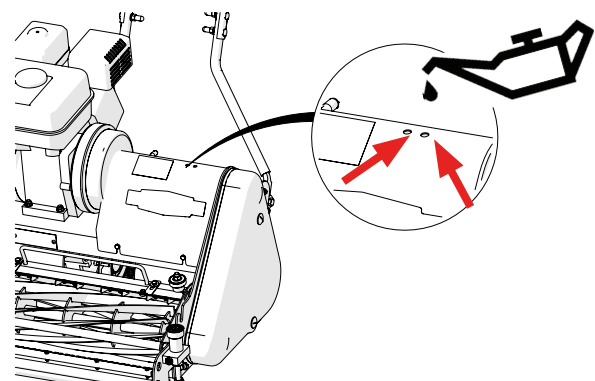
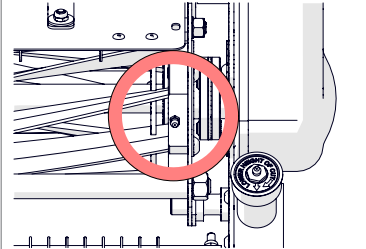
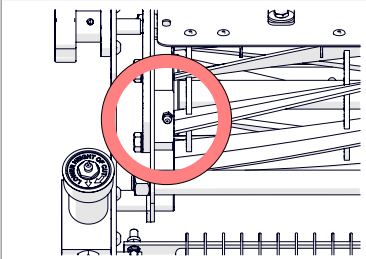
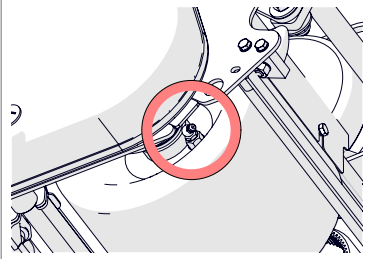
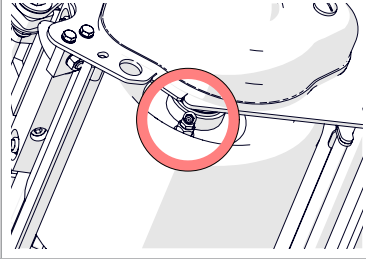
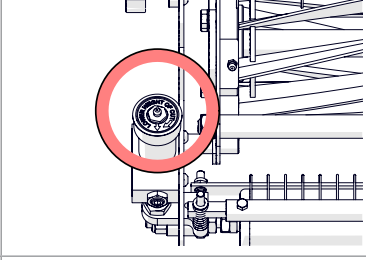
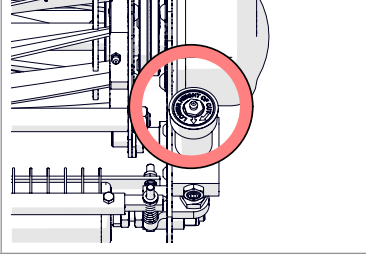

Fig.23. Dog Clutch Oiling

6. Maintenance and Service

6.2.6. Greasing points

Grease the following locations at the intervals stated. We recommend to use a grease gun with a multipurpose lithium EP2 grease.

Location		Frequency
Cylinder bearing, left side		One pump post-use
Cylinder bearing, right side		
Rear roller, left side (access from underneath)		One pump weekly or every 25hrs
Rear roller, right side (access from underneath)		
Cut height adjuster, right side		
Cut height adjuster, left side		

6.3. Cleaning



CAUTION - WATER DAMAGE

Do *not* use a pressurised hose to clean your machine. Doing so may cause water ingress, damage and invalidate your warranty.



WARNING - SAFETY

Never place your hands inside the cassette area without firstly turning the machine *off*. We recommend to wear safety gloves and to use a long handled brush for cleaning.

Use a soft brush to remove as much grass and debris as possible. If further cleaning is required:

- **Chassis** - Remove the grass box and tilt the machine backwards so it rests on the handlebars. Using a low pressure hose, wash all of the grass from under the machine and around the cassette. Take extra care around the bearings, avoiding direct contact with the hose. Dry thoroughly after use.
- **Engine** - Allow to cool for at least 30mins before cleaning. Do *not* use a hose or pressurised hose to clean as this can cause damage. Use a damp cloth and brush.
- **Grass box** - Use a low pressure hose to rinse the inside of the box. Leave upside down to drip-dry before returning back to the machine.

6. Maintenance and Service

6.4. Handling and Transport



WARNING - LIFTING

Do *not* lift the machine as it does *not* have designated lifting points. Lifting the machine may result in injury, damage to the machine, or both.

- Use a ramp to aid the machine onto a vehicle. For the technical specification of the machine, please refer to "**4.1. Technical Specifications**" p.13. The weight can also be found on the serial number plate.
- Anchor the machine to the floor/pallet using suitably rated tie-down straps. Anchor around the front and rear tie-bars (highlighted red in Fig. 24).
- Transport with fuel emptied - see note.
- Turn the machine *off* during transport (both from the engine and control components on the handlebar).



NOTE - SHIPPING THE ENGINE

Legislation for transporting and shipping a machine with an engine vary country to country. In most cases the fuel tank and carburettor must be completely emptied before transport. Additional requirements may include certification, declarations and packaging requirements. Always follow the requirements for your country and destination.

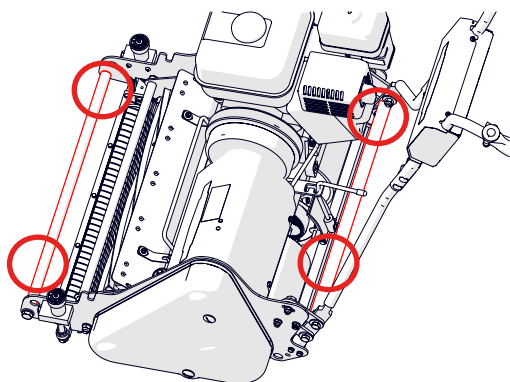

Fig.24. Anchor points for transport.

6.5. Storage



CAUTION - INCORRECT STORAGE

- Failure to store the machine correctly will cause machine degradation and reduce its operating life.
- The points below exclude specific requirements for the engine and fuel. Refer to the supplied OEM 'Owner's Manual' for these storage requirements.

Follow the points below for correct storage of your machine:

- Store in a location away from direct sunlight, flames, heat sources and areas with high shock/vibrations.
- Store in a location maintaining a consistent temperature between -20 to +35°C. Avoid high fluctuations.
- Store in a location that is dry, preferably with a relative humidity between 30%–70% RH.
- Thoroughly clean and dry the machine prior to storage.
- Apply a small amount of grease to the cutting edge of the cylinder and shear blade. Use a small brush to achieve this.
- Store on a flat surface with the parking brake *on*. Chock the front and rear of the machine.
- Cover the machine to protect from damage and dust.

6. Maintenance and Service

6.6. Disposal

6.6.1. Machine Disposal



NOTE - DISPOSAL NOTES

Check and comply with all environmental regulations and local disposal guidelines.

Dispose of the product in an environmentally friendly manner. The machine is predominately made up from metal waste - these can be suitably recycled at a local refuse collection site.



CAUTION - INJURY

Take care when removing components from the machine. If done incorrectly it may cause injury to yourself or damage to the surrounding environment. Wear suitable PPE and dismantle in an appropriate area.

1. Take the machine to a suitable area to allow for the removal of parts. Take into account access to the machine, tool availability, oil and other contaminants.
2. Wear suitable PPE. This must include safety glasses and gloves as a minimum.
3. Place oil absorbent pads under and around the machine.
4. Safely drain all fluids from the machine and engine, including oil and fuel. Use appropriate containers to collect these fluids and clearly label with their contents.
5. Clean the machine thoroughly.
6. Detach any removable parts, such as the handlebar, bodywork, rollers and cassette.
7. Separate recyclable parts like metal, plastic and electronic. Recycle at a recycling facility.
8. Dispose of non-recyclable components in accordance with local waste disposal regulations.
9. Document the decommissioning process for record keeping.

6.6.2. Hazardous Materials

The engine contains petrol and oil which are classed as hazardous waste. Dispose of at a suitable recycling facility.

Other components to note include lubricating grease and roller bearing oil which may contaminate waste during recycling. The oil and grease should be removed prior to disposal with a suitable solvent or degreaser such as brake cleaner /denatured alcohol and wipes.

6.7. Troubleshooting & FAQ



WARNING - SAFETY

- You **must** turn the machine **off** before actioning any cause. Failure to do so may cause major injury.
- Always wear suitable PPE for the job at hand.

The most common troubleshooting issues are shown in Appendix C. If your fault is not shown or you are still experiencing problems, please contact Howardson Group directly.

6.8. Warranty Policy

For full warranty terms and conditions, please contact your Dealer or refer to the warranty policy supplied separately.

Appendix A. Optional Items and Attachments

A1. Weile (Grooved) Roller

This option replaces the standard smooth front roller with a weile (grooved) roller. A weile roller has less surface area so the machine sits lower in the turf, allowing for the leaf blades to stand more upright in the grooves prior to being cut. This generally achieves a more consistent height and quality of cut. The grooves also help maintain better traction, so more suited to thicker turf, uneven ground and slopes.

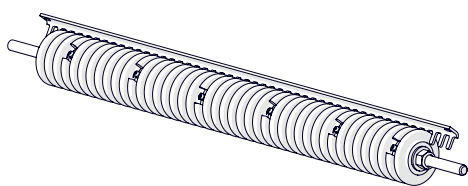

However, a smooth roller distributes the machine weight more evenly provides and is therefore less aggressive on the turf. Use a smooth roller on well maintained level turf, or if your turf is stressed, recently aerated or in soft ground conditions.

To remove and swap the front roller:

1. Fully loosen both LH and RH height adjusters as far as they can go (Fig. 25A). This will allow the front roller, end blocks, comb tine and scraper bar to be removed as one from the machine (Fig.25B).
2. Remove the comb tine and scraper bar [10 mm spanner]. This will allow the end block to be removed (Fig.25C).
3. Assemble the end block and comb tine (if applicable) onto the weile roller.
4. Assemble the end block with weile roller back onto the machine, using the height adjusters to screw back in.
5. Perform cut-height adjustment "**5.2.2. Adjusting Height (Cutting)**" p.26.

Fig.25. Front roller removal

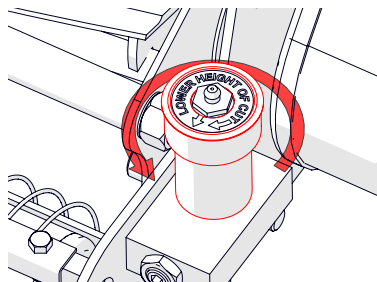

Fig.25A - Loosen height adjusters.

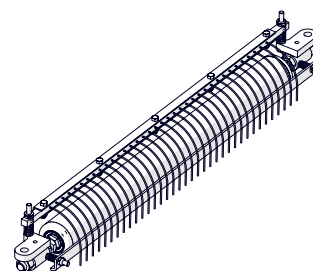

Fig.25B - Whole front roller assembly.

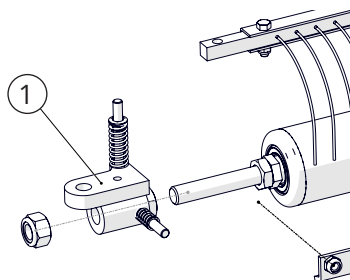

Fig.25C - Remove comb tine and scraper to gain access to end block (1).

Appendix

Appendix B. Service Kit

The service kits below are available to be purchased to aid in the servicing of the machine:

Machine	Service area of machine	Kit number	Item description	Item part number	Qty
All	(SK02) - REAR ROLLER	SK02012	BEARING R18 2RS	J20454	2
			BEARING RLS8 2RS	J20455	1
			GRUB SCREW M8 X 8	J20467	2
			CIRCLIP INTERNAL 57 X 2	J20474	1
			CIRCLIP INTERNAL 54 X 2	J20475	2
			Roller Drive Belt	J209003	1
			TENSIONER PULLEY	J209047	1
			CSK CAP HEAD M6 X 25	SP01056	1
	(SK04) - HANDLES	SK04004	Throttle Cable	J20112	1
			Brake Band Cable	J20113	1
	(SK05) - DRIVE / POWER	SK05015	Roller Drive Belt	J209003	1
Cylinder Drive Belt			J209005	1	

Appendix C. Troubleshooting & FAQ

Issue	Possible Cause	Action
Engine won't start	[See OEM 'Owner's Manual']	[See OEM 'Owner's Manual']
Engine lacks power	[See OEM 'Owner's Manual']	[See OEM 'Owner's Manual']
Engine starts but stalls	<ol style="list-style-type: none"> 1. Choke left in the 'closed' position after warm-up. 2. Dirty carburettor. 3. Blocked fuel line or filter. 4. Low oil level triggering shutoff. 	<ol style="list-style-type: none"> 1. Move choke to the 'open' position. 2. Clean carburettor. 3. Inspect and clean fuel system. 4. Check oil level.
Engine runs rough or misfires	<ol style="list-style-type: none"> 1. Dirty or incorrect spark plug gap. 2. Contaminated fuel. 3. Air leak in intake system. 4. Clogged air filter. 5. Choke left in the 'closed' position after warm-up. 	<ol style="list-style-type: none"> 1. Clean or replace spark plug, check gap. 2. Drain and replace fuel. 3. Inspect intake gaskets and connections. 4. Clean or replace air filter. 5. Move choke to the 'open' position.

Appendix

Issue	Possible Cause	Action
Grass does not cut.	<ol style="list-style-type: none"> 1. Cutting height is higher than grass length. 2. Gap between cylinder and shear blade is too much. 3. Cylinder and shear blades not sharp. 	<ol style="list-style-type: none"> 1. Adjust cutting height so it is below current grass height. 2. Adjust the shear blade - see "5.2.5. Shear Blade Adjustment" p.30. 3. See "6.2.2. Backlapping" p.46. If backlapping not sufficient, remove and re-sharpen using professional grinder/ services.
Cassette keeps spinning with the clutch rod in the 'disengaged' position.	<ol style="list-style-type: none"> 1. Cassette belt tension incorrect. 2. Top drive mis-alignment from the engine output shaft. 	<ol style="list-style-type: none"> 1. Re-tension cassette belt. See "6.2.1. Cassette and Drive Belt Replacement/Tensioning" p.44. 2. With a hammer, gently tap the top drive pulley towards the engine.
Cassette does not spin with the lever in the 'engaged' position.	<ol style="list-style-type: none"> 1. Cassette belt tension incorrect. 2. Top drive mis-alignment from the engine output shaft. 3. Clutch rod not adjusted correctly. 	<ol style="list-style-type: none"> 1. Re-tension cassette belt. See "6.2.1. Cassette and Drive Belt Replacement/Tensioning" p.44. 2. Inspect the dog drive and adjust where required. 3. Inspect the clutch rod and adjust where required.
OPC will not disengage when released	<ol style="list-style-type: none"> 1. Check the OPC operates freely and no damage to pivot block. 	<ol style="list-style-type: none"> 1. Service/replace OPC if faulty.

DENNIS



Email
sales@howardsongroup.com

UK & International
Tel: +44 (0) 1332 824777

Head Office
Ashbourne Road, Kirk Langley,
Derby DE6 4NJ, UK

Due to a policy of continual development Howardson Group Ltd reserves the right to change specification without prior notification.
All goods sold subject to the company's terms and conditions of sale, copies available on request.

E&EO