

Instruction Manual

Petrol Cassette Mower

G660 / G760 / G860



DENNIS

Original Instructions in English (UK).
 Part number: SP20004_EN.
 Models covered: G660 (D055) / G760 (D053) /
 G860 (D054).

Rev.	Date	Description of Changes	Author
5.0	01/ NOV/ 2023	E1079 - CE Certification Updated as per noise testing. Sheets are copied from rev4 PDF. Due to copying restrictions, most information is copied in image format and will require replicating if modifications are required.	S.H.
6.0	28/ NOV/ 2025	Complete redesign of manual.	C.B

For a digital copy of this manual, parts catalogue and other information regarding this product, please scan:



For a digital copy of the Honda engine documentation, please scan:



Serial numbers:

Chassis
Engine

Head Office

Howardson Works,
 Ashbourne Road,
 Kirk Langley,
 Derbyshire,
 DE6 4NJ,
 UK
 Tel: +44 (0) 1332 824 777
 howardsongroup.com

Copyright © 2004-2025 by Howardson Group Ltd. All Rights Reserved.

This document and all content within it, is protected by copyright and is the property of Howardson Group Ltd. You may not distribute, modify, transmit, copy or use the content of this document in any way, electronic or otherwise, whether in whole or in part, for commercial purposes or for personal gain. Any storage, reproduction or redistribution of the content by any means is prohibited without prior written consent from Howardson Group Ltd. You may store extracts from this document for your personal use only.

While every effort has been made to ensure the accuracy and completeness of the information contained in this manual, we assume no responsibility or liability for errors or omissions. The information provided is on an "as is" basis without any warranties of any kind, either expressed or implied. We reserve the right to make changes to the product and its documentation at any time without prior notice. This includes, but is not limited to, modifications to the design, specifications, and functionality of the product. The latest version of the manual will be available on our website or through our customer service department. Some imagery may not reflect the actual product you have.

Table of Contents

1. Introduction and Safety Information 5

1.1. Introduction	5
1.1.1. Operator Manual Overview	5
1.1.2. Machine Description	5
1.2. Safety Instructions	6
1.2.1. Warning Symbols & Decals	6
1.2.2. Important Safety Instructions	8
1.2.3. Intended Use and Residual Risks	9
1.2.4. Personal Protective Equipment (PPE)	9
1.3. Assembly, Installation and Commissioning	9
1.3.1. Unpacking and Inspection	9
1.3.2. Assembly Instructions	10
1.3.3. Installation Requirements	10
1.3.4. Commissioning	10
1.3.5. Calibration	10

2. Machine Overview 11

2.1. Technical Specifications	11
2.1.1. Dimensions	11
2.1.2. Specification Table	12
2.1.3. Noise and Vibration	13
2.2. Machine Components	14
2.3. Control Components	16
2.4. Engine Components	18
2.5. Cassettes	19

3. Operation and Emergency Procedures 22

3.1. Pre-Start Maintenance and Safety Checks	22
3.2. Starting the Engine	22
3.3. Stopping the Engine	23
3.4. Drive	24
3.4.1. Moving and Transport (no cut)	24
3.4.2. Moving (with cut/scarify/brush)	25
3.4.3. Operating on Slopes	26
3.5. Cutting Preparation	26
3.5.1. Removing and Inserting a Cassette	26
3.5.2. Adjusting Height of Cut (Cylinder)	28

3.5.3. Adjusting Height of Cut (Scarification, Dethatching and Brushing)	30
3.5.4. Cutting Technique	31
3.6. Engine	32
3.6.1. Safety Information	32
3.6.2. Refuelling	32
3.6.3. Installation and Removal	32
3.6.4. Engine Specifications	33
3.6.5. Replacement and Disposal	33
3.7. Operating Environment	33
3.8. Emergency Procedures	34
3.8.1. In the Event of a Breakdown	34
3.8.2. Hazardous Substances and Fire	34

4. Maintenance and Servicing 36

4.1. Maintenance Schedule	36
4.2. Servicing Instructions	39
4.2.1. Cassette and Drive Belt Replacement/Tensioning	39
4.2.2. Transmission Belt Replacement/Tensioning	42
4.2.3. Backlapping	43
4.2.4. Grinding Cutting Blades	44
4.2.5. Checking/Tensioning Parking Brake	46
4.2.6. Changing Rear Roller Oil	46
4.3. Adjustments and Settings	47
4.3.1. Handlebar Height Adjustment	47
4.3.2. Shear Blade Adjustment	48
4.3.3. Guide Peg Adjustment	49
4.4. Cleaning	50
4.5. Handling and Transport	50
4.6. Storage	51
4.7. Disposal	51
4.7.1. Machine Disposal	51
4.7.2. Hazardous Materials	52
4.8. Troubleshooting & FAQ	52
4.9. Warranty Policy	53

Table of Contents

Appendix **54**

Appendix A. Optional Items and Attachments . . .	54
A1. Weile (Grooved) Roller	54
A2. Suspension trailer seat	55
Appendix B. Service Kit	55

List of Key Figures

<i>Figure (Fig.) 1 - Viewpoints</i>	<i>5</i>
<i>Fig.2 - Assembly Instructions</i>	<i>10</i>
<i>Fig.3 - Machine components overview.</i>	<i>14</i>
<i>Fig.4 - Serial plate components overview.</i>	<i>15</i>
<i>Fig.5 - Control components overview.</i>	<i>16</i>
<i>Fig.6 - Engine components overview.</i>	<i>18</i>
<i>Fig.7 - Power on procedure</i>	<i>22</i>
<i>Fig.8 - Power off procedure</i>	<i>23</i>
<i>Fig.9 - Driving procedure</i>	<i>24</i>
<i>Fig.10 - Cutting procedure</i>	<i>25</i>
<i>Fig.11 - Removing and Inserting a Cassette</i>	<i>27</i>
<i>Fig.12 - Adjusting Height of Cut</i>	<i>28</i>
<i>Fig.13 - Setting bar measurement for above/below ground cassettes.</i>	<i>30</i>
<i>Fig.14 - Drive belt replacement / tensioning</i>	<i>40</i>
<i>Fig.15 - Handlebar adjustment</i>	<i>42</i>
<i>Fig.16 - Backlapping</i>	<i>44</i>
<i>Fig.17 - Recommended cylinder grind angle</i>	<i>45</i>
<i>Fig.18 - Recommended shear blade grind angle</i>	<i>45</i>
<i>Fig.19 - Illustration of two different shear blade angles and their grass contact point</i>	<i>45</i>
<i>Fig.20 - Rear roller oil</i>	<i>47</i>
<i>Fig.21 - Handlebar adjustment</i>	<i>47</i>
<i>Fig.22 - Shearblade adjustment</i>	<i>48</i>
<i>Fig.23 - Guide peg adjustment</i>	<i>49</i>
<i>Fig.24 - Anchor points for transport.</i>	<i>50</i>
<i>Fig.25 - Weile Roller</i>	<i>54</i>
<i>Fig.26 - Front roller removal</i>	<i>54</i>
<i>Fig.27 - Suspension trailer seat (frame only).</i>	<i>55</i>

1. Introduction and Safety Information

1.1. Introduction

1.1.1. Operator Manual Overview

This operator manual contains important information regarding the safe, proper and efficient operation of the G660/G760/G860, referred to as 'machine' in this manual. This operator manual must always be available and read by every User of the machine. 'User' is defined as an authorised person tasked with working on or with the machine, typically operators, groundskeepers and maintenance personnel.

Adherence to this operator manual will help to avoid and minimise risk to you as the User and to the machine. It will also lead to a greater quality of cut, lower repair costs and reduce downtimes. Prior to use, every User must ensure they have:

- Fully read and understood these instructions,
- Understood the machine controls,
- Understood the dangers and hazards involved, and methods to mitigate risk.

Reference will be made to the use, safety and maintenance of the petrol engine. However this is supplementary information only and you must also read the supplied OEM manual for the engine.

In the case of any difficulty or if further information is required, call Howardson Group or your Dealer. In the interests of speed and accuracy of information, please quote the serial number of the machine when making enquiries.

Location descriptions (e.g. left/right hand) throughout this manual are observed from the operators view whilst in normal drive position, as per Fig.1.

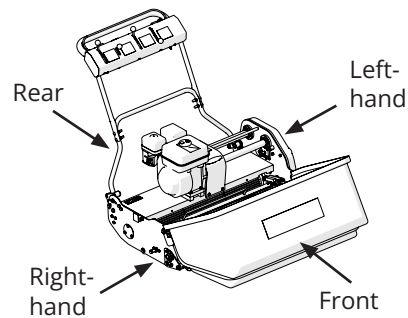

Figure (Fig.) 1 - Viewpoints

1.1.2. Machine Description

The G660, G760 and G860 are professional petrol grass mowers, using a 660 mm (26"), 760 mm (30") or 860 mm (34") cassette respectively. These cassettes are interchangeable, each used for a different application including cutting, brushing, scarifying, verti-cutting and sorrel rolling.

All models are powered by an air cooled, single cylinder, four stroke petrol engine, the specification of which can be found in the supplied OEM manual, or selected specifications in this manual.





The rear roller and cassette are controlled independently, operated from the controls located on the handlebar.

The design of the machine incorporates a system for quick adjustment of the height of cut and a sectional assembly system for easy service and maintenance of the main components. A mechanical parking brake is fitted which, when applied, prevents drive being engaged.

1. Introduction and Safety Information

1.2. Safety Instructions

Throughout this manual, potential safety risks are identified with a word and coloured coded box. They denote the following:

 <p>DANGER</p> <p>Indicates an imminently hazardous situation which, if not avoided, will result in death or serious injury.</p>	 <p>WARNING</p> <p>Indicates a potentially hazardous situation which, if not avoided, could result in death or serious injury.</p>
 <p>CAUTION</p> <p>Indicates a potentially hazardous situation which, if not avoided, may result in minor or moderate injury.</p>	 <p>NOTE</p> <p>Indicates information considered important but not hazard related.</p>

1.2.1. Warning Symbols & Decals

The following symbols and decals are used throughout this Operator Manual and across the machine. Familiarise yourself with them prior to operating the machine. They are located near areas of potential danger or convey further information on machine use.

Warning Signs



General warning sign



Warning; Explosive material



Warning; Sharp element



Warning; Toxic material



Warning; Flammable material



Warning; Corrosive substance



Warning; Crushing of hands

Prohibition Signs



General prohibition sign



No smoking



No open flame; Fire, open ignition source and smoking prohibited



No metallic articles or watches



Do not touch



No sitting



Do not alter the state of the switch



Not to be serviced by users

1. Introduction and Safety Information

Mandatory Signs



General mandatory action sign



Refer to instruction manual/booklet



Wear ear protection



Wear eye protection



Wear a mask



Wear safety footwear



Wear protective gloves



Wear protective clothing



Disconnect before carrying out maintenance or repair

Other Signs



Take note



Recycle



Heavy weight

Decals

Your machine decals must be replaced when they become worn or damaged. Contact Howardson Group Service department with the part number listed below:



229600



229601



229602



229603



229599



229375



229376



B32903_REV0



SP18037



B32902_REV2
(200x50mm)
J20362_REV2 (120x30mm)

1. Introduction and Safety Information

1.2.2. Important Safety Instructions



- **Always** read this operator manual carefully and understand the controls and safety signs before commencing work. Improper use or care of the machine may result in injury or death.
- This machine is dangerous if not used correctly - take great care and consideration when using it.
- **Always** keep hands, feet and any other body part clear of the cassette and rollers. Remember that blades, brushes and rollers can continue to rotate even after the engine has stopped.
- **Always** use the correct personal protective equipment (PPE) - see "1.2.4. Personal Protective Equipment (PPE)" p.9.
- **Always** use the machine with all safety guards correctly fitted. They are supplied for your protection.
- **Always** operate the engine in a well ventilated space.
- **Always** read and understand the engine OEM 'Owner's Manual' before using the machine.
- **Always** store the petrol in a suitable container, away from direct sunlight, high temperatures and areas with risk of sparks.
- **Always** disengage the drive and cassette levers before starting the engine. Start the engine carefully following the instructions.
- **Always** be alert for pedestrians.
- **Always** stop the engine and allow to cool *entirely* before servicing or making repairs.
- **Always** wait for the cassette to stop rotating before travelling over anything that is not grass.



- **Always** keep the machine maintained with the schedule and procedures found in "4. Maintenance and Servicing" p.36. Doing so keeps the machine in good condition, thereby reducing accidents and injuries, and maintaining better turf.
- **Always** operate standing behind the machine with two hands on the handlebar.
- **Always** assess the job prior to starting. This includes:
 - Slopes - mitigate use on slopes where possible. Take extra caution and use horizontally across the face of slopes, not up and down.
 - Remove any debris and objects such as stones and branches prior to working in the area. Also observe and avoid anything that can damage the machine such as sudden dips, verges etc
 - Lighting - always operate in daylight or good artificial light.
- **Never** use the machine if it is damaged or faulty in any way.
- **Never** put any body parts, including limbs, near moving parts of this machine.
- **Never** operate the engine in a confined space as carbon monoxide fumes can accumulate.
- **Never** smoke or have naked flames around the machine.
- **Never** change engine governor settings or overspeed the engine.
- **Never** carry out adjustments whilst the machine is running.
- **Never** allow any unauthorised person to operate the machine, in any way, at any time.

1. Introduction and Safety Information



- **Never** operate the machine if you are experiencing any of the following conditions: illness, reduced physical capacity, or under the influence of drugs or alcohol.
- **Never** let a child operate the machine or be in the work area when it is being operated.
- **Never** lift or carry a machine whilst any parts are moving.
- **Never** use the machine in adverse weather conditions, particularly in heavy rain, storms or high winds.
- **Never** use the machine at a speed greater than your walking pace.

1.2.3. Intended Use and Residual Risks

This machine is designed for the cutting and maintenance (scarify, brush etc) of grass lawns with Dennis, machine specific cassettes. Any use beyond this is outside the scope of this machine and could cause injury or damage to the machine. This includes, but not limited to, riding on the machine, using it to transport goods and using it to cut thick vegetation.



Personal injury and damage to the machine can result in using the machine for alternative uses. **Never** use the machine for anything else other than its intended use. Risks will always be present and you must be vigilant at all times while operating machine.

You must follow instructions and information found in "1.2. Safety Instructions" p.6 and "3.7. Operating Environment" p.33.

1.2.4. Personal Protective Equipment (PPE)

During use you must adhere to local rules and regulations regarding Personal Protective Equipment (PPE). In addition to this we recommend:



- **Footwear;** heavy duty, slip resistant boots to protect against injury.



- **Eye protection;** to protect from flying debris.



- **Hearing protection;** must be worn at all times when the machine is activated.



- **Clothing;** suitable for the environment you are operating in (hot, cold, wet etc)



- **Hand protection;** to avoid cuts and blisters.



- **Respiratory protection;** for when there are occurrences of high dust and pollen.

1.3. Assembly, Installation and Commissioning

1.3.1. Unpacking and Inspection

The machine will arrive on a wooden pallet base, with either a cardboard or wooden outer frame. Carefully remove this outer packaging. You alternatively may have the machine delivered direct from our factory or your Dealer.

Visually inspect the machine for any signs of damage which may have occurred during transport. Contact Howardson Group or your Dealer as soon as possible should there be damage.

Included with the machine is this operator manual, a warranty registration document and machine parts catalogue.

1. Introduction and Safety Information

To remove the machine from the pallet:

1. Remove all tie-down straps.
2. Wherever possible, use a suitably rated ramp to roll the machine off backwards to the ground. Refer to sections "**3.2. Starting the Engine**" p.22 and "**3.4. Drive**" p.24 for the relevant procedures. Gently toggle the park brake on/off to aid going down the ramp.



The machine is very heavy. Machine weight can be found on the serial plate or section "**2.1.2. Specification Table**" p.12. Take care when removing from the wooden pallet - we recommend two people to help with this. Follow all manual handling techniques for your business and region.

3. If a ramp is not available, disengage the parking brake and, while following correct manual handling techniques, **gently** lower the rear roller to the floor. Continue to roll backwards, keeping pressure on the handlebar so the front wheels remain in the air. Once clear of the pallet, lower the front to the floor **gently**.

Dispose of all packaging according to local laws - recycle where possible.

1.3.2. Assembly Instructions

Minimal assembly is required to get your machine into a ready state:

1. **Attach the grass box**; lower the grass box frame towards the front of the machine (Fig.2A). Lift the grass box onto this frame (Fig.2B), removing any plastic wrapping that may be left.
2. **Set handlebar height**; the handlebar may need readjusting to be optimum for your height. See section "**4.3.1. Handlebar Height Adjustment**" p.47 for further information.

3. **Fill the fuel tank** with unleaded petrol (see OEM manual supplied for more information).

Fig.2 - Assembly Instructions

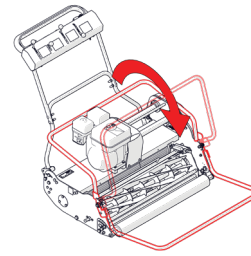

Fig.2B - Lower grass box frame.

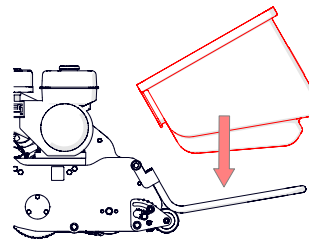

Fig.2B - Grass box fitment.

1.3.3. Installation Requirements

Adjustments will be required to make adequate space for the storage and routine maintenance of the machine:

- See section "**2.1.1. Dimensions**" p.11 for minimum space requirements.
- See section "**4.6. Storage**" p.51 for correct storage requirements.

1.3.4. Commissioning

Your Dealer or a Howardson Group representative will be present to commission and set-up your machine. They will walk through the process of basic controls and getting started with your machine.

1.3.5. Calibration

No calibration procedures are required.

2. Machine Overview

2.1. Technical Specifications

2.1.1. Dimensions

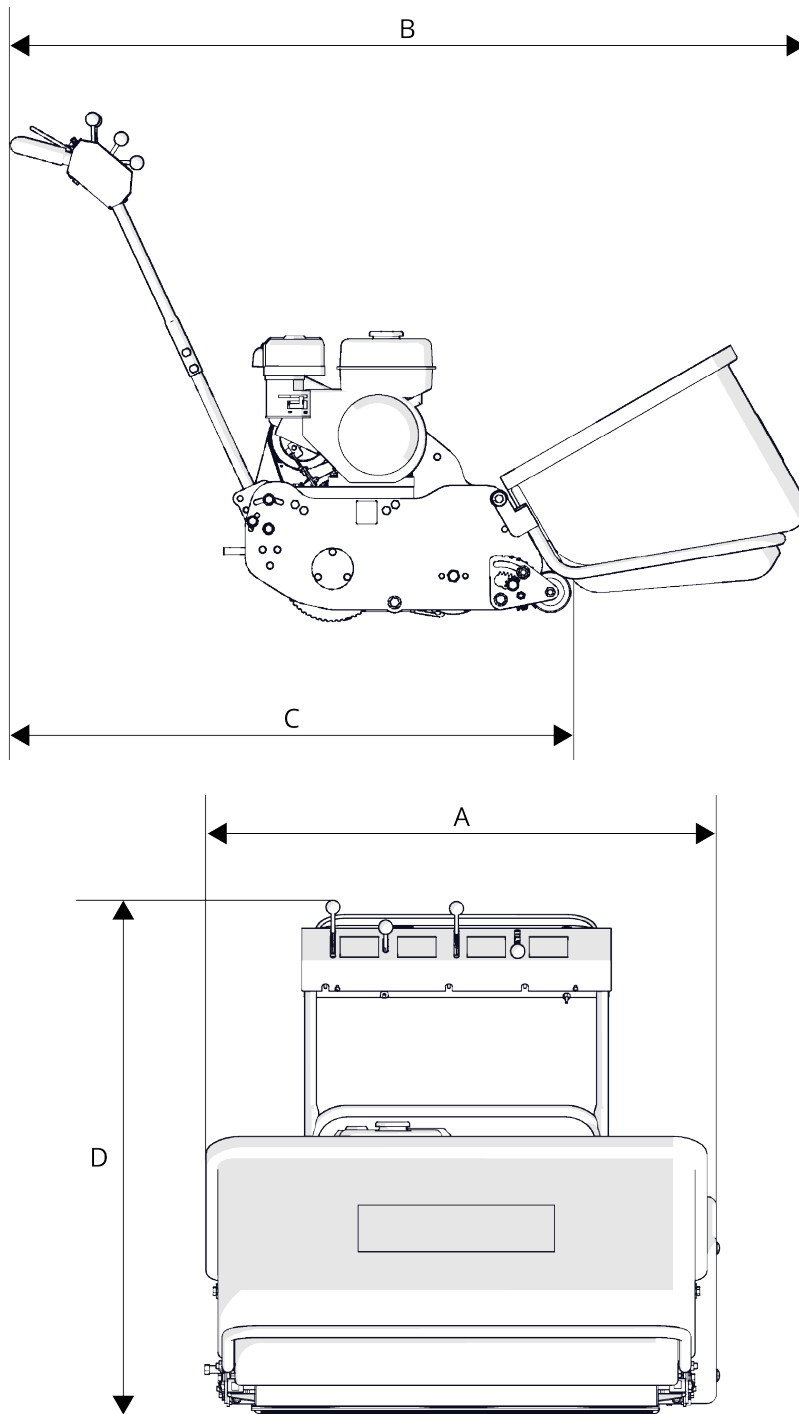

View	Model		
	G660	G760	G860
A	884mm	984mm	1084
B	1635mm		
C	1121mm		
D	1119mm		

2. Machine Overview

2.1.2. Specification Table

System		Model			
		G660	G760	G860	
Weight	Machine (without cassette)	146 kg	156 kg	162 kg	
	Cassette only	See "2.5. Cassettes" p.19			
Drive	Engine ¹	Type	Petrol Engine		
		Model	Honda GX160		Honda GX200
		Net Power	3.6 kW / 3,600 rpm		4.8 kW / 3,600 rpm
		Fuel Tank Capacity	3.1 L		
		Engine Oil Capacity	0.6 L		
		Engine Oil Type	Genuine Honda, SAE 10W-30		
		Dry Weight	15.1 kg		16.1 kg
		Spark Plug Type	BPR6ES (NGK) or W20EPR-U (DENSO)		
		Spark Plug Gap	0.7-0.8 mm		
		Rear Roller System	'V' Belt		
	Cassette Drive System	Multi 'V' Belt			
Speed (maximum)	Forwards	3.21 km/h			
Cutting	Blade unit	Cassette - removable			
	Cutting Width	660 mm [26"]	760 mm [30"]	860 mm [34"]	
	Number of blades	6, 8, 11		4, 6, 8, 11	
	Height of cut	08-47 mm			
	Clips per Metre	4 blade	-	-	68
		6 blade	103		
		8 blade	137		
11 blade		-	-	189	
	Grassbox volume	160 L	180 L	200 L	

2. Machine Overview

System		Model		
		G660	G760	G860
Environmental	Operating temperature range	-15 °C to +40 °C (+10 °C to +30 °C optimal for grass cutting)		
	Storage temperature range	0 °C to +30 °C For additional information, see section " 4.6. Storage " p.51.		

¹For technical specifications of the engine, please refer to the 'Owner's Manual' supplied.

2.1.3. Noise and Vibration

System		Model		
		G660	G760	G860
Noise	Measured Sound Power Level	91 dB(A)	93 dB(A)	92 dB(A)
	Guaranteed Sound Power Level	95 dB(A)	98 dB(A)	95 dB(A)
	 WARNING - NOISE LEVELS Hearing protection must be used when using this machine.			
Vibration	Total value to which the hand-arm system is subjected (3.1 m/s ²	3.1 m/s ²	3.1 m/s ²

2. Machine Overview

2.2. Machine Components

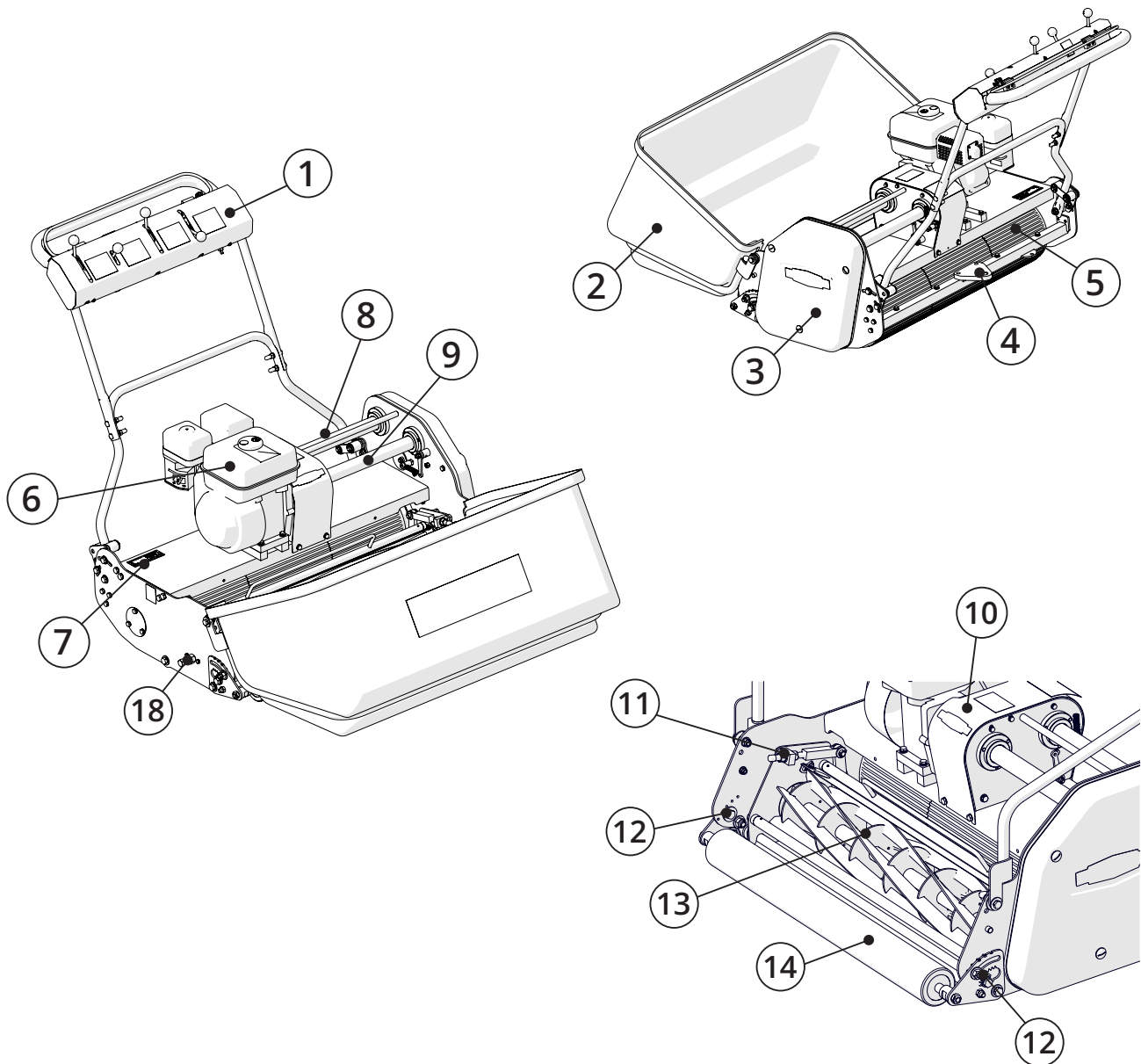

Fig.3 - Machine components overview.

- | | |
|-----------------------|--|
| 1. Control Components | 8. Driveshaft guard - Rear Roller |
| 2. Grass Box | 9. Driveshaft guard - Cassette |
| 3. Belt Guard | 10. Transmission guard |
| 4. Towbar Bracket | 11. Shear Blade Adjuster |
| 5. Rear Roller | 12. Cut Height Adjuster |
| 6. Engine | 13. Cassette; <i>type depending on order</i> |
| 7. Serial plate | 14. Front roller |

2. Machine Overview

1. Control Components

See "2.3. Control Components" p.16.

2. Grass Box

The grass box collects the clippings from the cassette. Maximum volume: G660 = 160 L, G760 = 180 L, G860 = 200 L.

3. Belt Guard

Behind the belt guard contains two belt and pulley assemblies; one set for the rear roller and one set for the cassette. This guard protects the operator and machine from injury and damage. It must be kept on and secured at all times.

4. Towbar Bracket

For use with the optional trailer seat attachment. See "A2. Suspension trailer seat" on page 55

5. Rear Roller

The rear roller maintains stability along with the front roller, but also creates a striping effect behind the machine. It is split into three segments, with the two outer segments operated by differential to aid in manoeuvrability.

6. Engine

Refer to supplied OEM manual and "2.4. Engine Components" p.18 for further information.

7. Serial Plate

The serial number can be found on the right-hand side of the machine, near the handlebar adjuster. Please make a note of the serial number of your machine and engine in the table found on the inside cover of this manual. Always quote these in any communication with Howardson Group. .

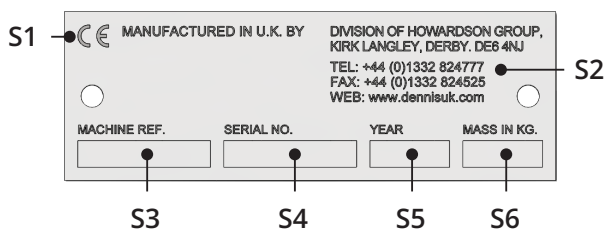

Fig.4 - Serial plate components overview.

S1. CE marking

S2. Business/manufacturer address and contact details

S3. Machine code designation

S4. Serial number

S5. Year of build

S6. Mass of machine (kg)

8 / 9. Driveshaft guards

Within each of these guards are drive shafts, transmitting power from the engine to the rear roller and cassette pulley/belts, respectively. They must be kept on and secured at all times.

10. Transmission Guard

Behind the transmission guard is a single belt and pulley assembly to split power from the engine to both cassette and rear roller drive shafts. Here is also the parking brake system composing of the brake pads and caliper. The guard must be kept on and secured at all times.

11. Shear Blade Adjuster

Over time the quality of cut will decrease due to blade wear. Adjustment of the shear blade carrier is required to maintain the cut "4.3.2. Shear Blade Adjustment" p.48.

12. Cut Height Adjuster

Located either side of the machine, cut height is adjusted here - see "3.5.2. Adjusting Height of Cut (Cylinder)" p.28.

13. Cassette

The cassette is a removal, interchangeable cartridge that houses specialised blades or discs to alter the function of the machine. Using the same drive system, the machine can use this power to perform different lawn care duties, including cutting, brushing and scarifying - for the full list of cassettes, see "2.5. Cassettes" p.19.

It is designed to be easily swapped with another cassette, changing the function of the machine in a matter of minutes.

Replace worn or damaged cassettes with genuine Dennis replacements.

2. Machine Overview



DANGER - CASSETTE BLADES/DISCS

Worn or damaged blades/discs are dangerous. Incorrect use or maintenance can cause serious injury or death. Inspect before and after every use, as per "4.1. Maintenance Schedule" p.36.

Always inspect the blades/discs with the machine **off**.

14. Front Roller

The front roller maintains stability and guides the machine. As standard, a Smooth roller is supplied but a Weile roller is available as an optional extra.

2.3. Control Components

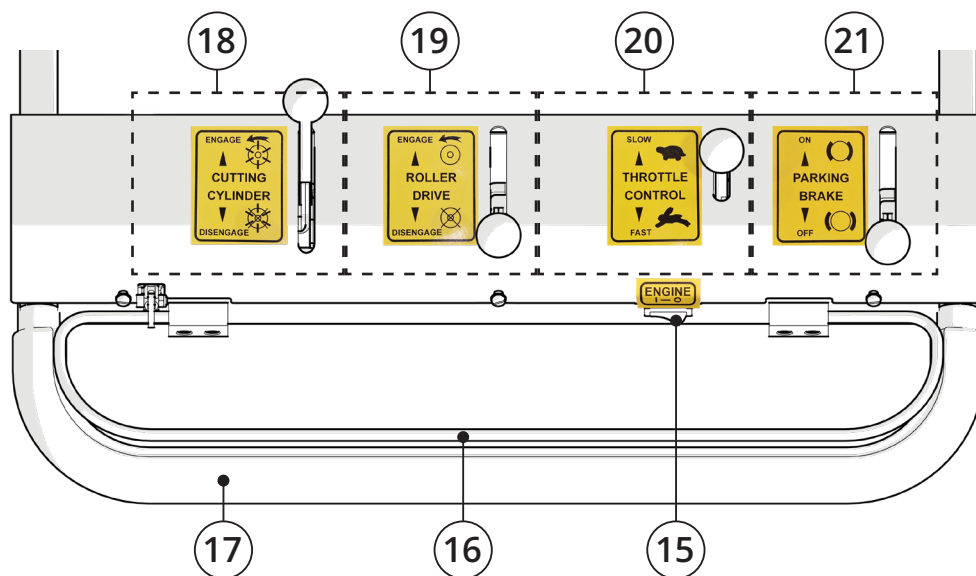

Fig.5 - Control components overview.

15. Start Switch

16. Operator Presence Control (OPC)

17. Handlebar

18. Cassette Lever

19. Drive Lever

20. Throttle Lever

21. Parking Brake Lever

15. Start Switch

The start switch is used for starting, and maintaining power, to the machine. Toggle to the **on** position prior to pulling the starter grip. This opens the grounding circuit for the spark plug to fire.

Toggle to the **off** position whenever the machine is not in use, or if immediate cut of power

is required. This grounds the ignition coil, preventing the ignition coil sending a voltage to the spark plug.



Fig.5A - Start button

2. Machine Overview

16. Operator Presence Control (OPC)

This lever mechanism is a safety feature to prevent accidents. It signals to the machine of your control, active or otherwise, and either supplies or stops power to the cassette, respectively.

The OPC requires continuous engagement for the cassette to be used. When used with the cassette lever in the on position, it powers the cassette motor.

When the OPC is released, this indicates you are no longer present or in control. At this, the machine immediately ceases all power to the cassette, regardless of lever position. This minimises risk caused by the machine being able to operate unattended or in unsafe conditions.



DANGER - BYPASSING OPC

Never interfere or tamper with the OPC in any way. This includes taping, tying up, altering the micro switch etc. Doing so bypasses a key safety mechanism of the machine and puts you and fellow pedestrians at risk.

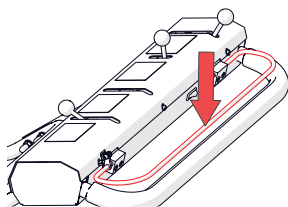

Fig.5B - OPC

18. Cutting Lever

This lever either engages/disengages power to the cassette. Push forward to engage (i.e. start spinning), or pull back to disengage (i.e. stop spinning). Only engage when the machine is on grass and is safe to do so.

19. Drive Lever

This lever either engages/disengages power to the rear roller. Push forward to engage (i.e. start moving forward), or pull back to disengage (i.e.

stop moving). Only engage when it is safe to do so.

20. Throttle Lever

This lever activates the speed of the machine. Push forward to engage tortoise (i.e. slow), pull back to engage hare (i.e. fast). The lever is proportional, therefore speed will alter depending on where it is positioned between the two. Choose the speed appropriate to the environment.

21. Parking Brake Lever

The mechanical parking brake physically stops the rotation of the rear roller driveshaft when engaged. This stops any unintended rolling and to be used when the machine is not in use. Push forward to engage (i.e. park brake on), or pull back to disengage (i.e. park brake off).



CAUTION - PARKING BRAKE

- **Always** engage the parking brake when the machine is not in use.
- Do **not** use the parking brake to stop the machine while moving. This may result in damage to the braking system. To stop, release the OPC and the machine will slow to a stop.

2. Machine Overview

2.4. Engine Components

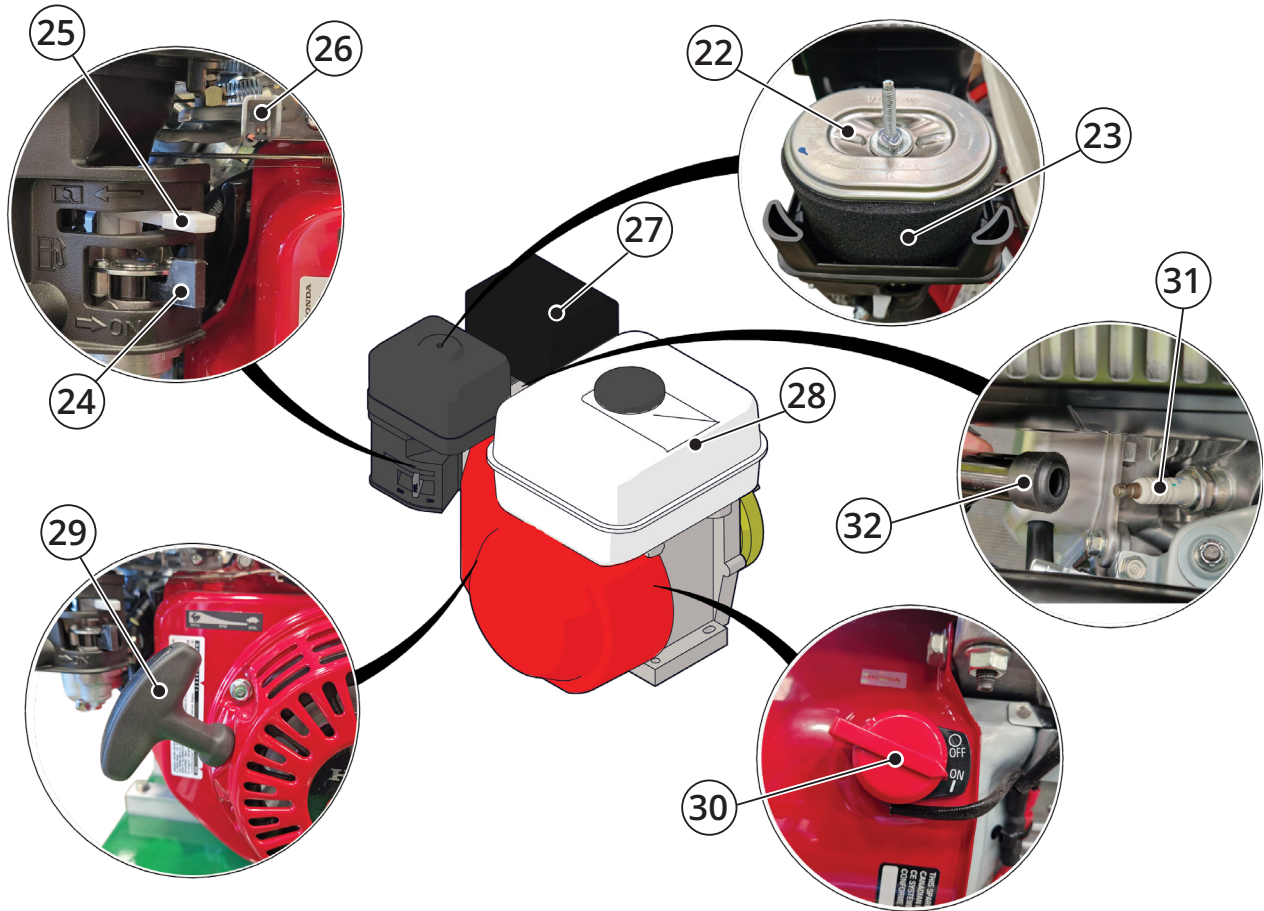

Fig.6 - Engine components overview.

- | | |
|-----------------------------|----------------------|
| 22. Air Filter (paper) | 28. Fuel Tank |
| 23. Air Filter (foam cover) | 29. Starter Grip |
| 24. Fuel Lever | 30. Engine On/Off |
| 25. Choke Lever | 31. Spark Plug |
| 26. Throttle Control Lever | 32. Spark Plug Cover |
| 27. Exhaust | |



Please refer to supplied OEM 'Owner's Manual' for description and use of each of the above components.

2. Machine Overview







2.5. Cassettes

Thirteen interchangeable cassettes are available for all G-Series machines. These are model specific and cannot be used interchangeably (i.e. a G660 cassette cannot be used in a G760/G860 machine and vice versa). Different cassette types are available for various grounds-care work, as outlined in the following table. With exception of the sorrel roller, they are all powered by the cassette pulley assembly allowing for easy interchangeability (the sorrel roller is free spinning and does not have the means to engage with the cassette drive).



For instructions on removing the cassette, see "3.5.1. Removing and Inserting a Cassette" p.26.

Type	Description and Use	Weight (kg)		
		G660	G760	G860
Cutting	6 Bladed Cylinder			
	 Six steel blades in a spiral format. Good general purpose cylinder and ideal for use on longer grass. As standard, no relief grind.	TBC	35.5	38.8
	8 Bladed Cylinder			
 Eight steel blades in a spiral format. Higher clip rate compared to 6 bladed cylinder and ideal for medium length grass. As standard, relief ground.	TBC	37.6	41.5	
11 Bladed Cylinder				
 Eleven steel blades in a spiral format. Higher clip rate compared to 8 bladed cylinder and ideal for short length grass. As standard, no relief grind.	TBC	TBC	38.9	

2. Machine Overview

Type	Description and Use	Weight (kg)		
		G660	G760	G860
Brushing				
Brush Soft Bristle				
	For moss and debris removal and use as a light scarifier for final pre-cut preparations.	<i>TBC</i>	<i>TBC</i>	19.1
Brush Hard Bristle				
	For moss and debris removal and use as a light scarifier for final pre-cut preparations.	<i>TBC</i>	<i>TBC</i>	19.1
Brush Multi-Dense				
	For moss and debris removal and use as a light scarifier for final pre-cut preparations.	<i>TBC</i>	18.0	19.5
Scarifying				
1 mm Scarifier				
	1 mm thick replaceable, wear resistant blades. 12 mm spacing for thatch removal throughout the season and autumn/spring renovation work.	<i>TBC</i>	<i>TBC</i>	<i>TBC</i>
2 mm Scarifier				
	2 mm thick replaceable, wear resistant blades. 12 mm spacing for thatch removal throughout the season and autumn/spring renovation work.	<i>TBC</i>	<i>TBC</i>	<i>TBC</i>
2 mm Scarifier Tungsten Tipped				
	2 mm thick replaceable, tungsten tipped blades. Designed for heavy duty thatch removal throughout the season and autumn/spring renovation work.	<i>TBC</i>	<i>TBC</i>	27.4

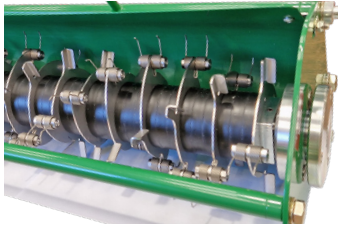
2. Machine Overview

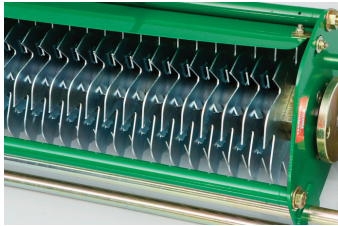
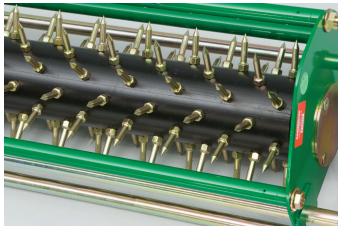
Type	Description and Use	Weight (kg)			
		G660	G760	G860	
Spring Tine Rake					
	 <p>Ideal for lifting lateral growth, helping to stand grasses up, removing dead matter or broken leaves. Helps to break up algae crust or help remove the glutinous slime that can sometimes appear on fine turf.</p>	TBC	21.4	23.4	
Verti-Cutter					
Verti-Cutters	 <p>1 mm thick 10 fingered replaceable discs. Regular use controls, thatch, lateral growth and the ingress of unwanted species such as annual meadow grass. Encourages vertical growth and ground cover. Cuts vertically into plant growth and above the soil, typically 2–3mm. Do not use to cut soil or during extended dry spells/drought.</p>	TBC	25.8	28.5	
	Verti-Cutter Tungsten Tipped				
	 <p>1 mm thick 10 fingered replaceable discs. Tungsten tip gives extra durability for heavy usage. Regular use controls, thatch, lateral growth and the ingress of unwanted species such as annual meadow grass. Encourages vertical growth and ground cover. Cuts vertically into plant growth and above the soil, typically 2–3mm. Do not use to cut soil or during extended dry spells/drought.</p>	TBC	25.3	28.0	
Sorrel Roller					
Sorrel Roller	 <p>Replaceable spikes relieves surface tension and allows penetration of air, water and fertilizer to the root zone. Good for over seeding and preparing damaged areas for repair.</p>	TBC	24.3	27.3	

3. Operation and Emergency Procedures

3.1. Pre-Start Maintenance and Safety Checks

Before using the machine, ensure all maintenance checks are complete, as per "4.1. Maintenance Schedule" p.36.

3.2. Starting the Engine



DANGER - POWER ON

- Prior to using the machine, ensure you read and understand this Operator Manual carefully. Failure to do so may result in personal injury and damage to the machine.
- Before turning the engine *on*, you *must* ensure the area is clear of people and obstacles, and all safety guards are present.
- Hearing protection must be worn prior and during use with the engine *on*.

To turn your engine *on*:

1. Set the parking brake to the *on* position (Fig.7A).
2. Set the engine switch (located on the engine) to the *on* position (Fig.7B).
3. Set the fuel lever to the *open* position (Fig.7C).
4. Set the choke lever to the *closed* position (Fig.7D). Note, setting the choke to this position is not required if the engine is warm or the air temperature is high.
5. Press the start switch (located with the control components) to the *on* position (Fig.7E).
6. Set the throttle lever to the *half-way* position (Fig.7F).
7. Grasp the starter grip handle and extend until the slack is removed. At this point, pull with a steady and fluid motion (Fig.7G). The engine will start.



NOTE - ENGINE START

Ensure the cassette and drive levers are both in the disengaged position before starting the engine. As a safety precaution, the machine will not start with these in the engaged position.

8. Allow the starter grip handle to return gently, avoid releasing it to 'snap' back into position.
9. Gradually move the choke lever into the *open* position (towards the front) (Fig.7H). Leave to warm up for 3-5 minutes while gradually moving the throttle to the tortoise position.

Fig.7 - Power on procedure

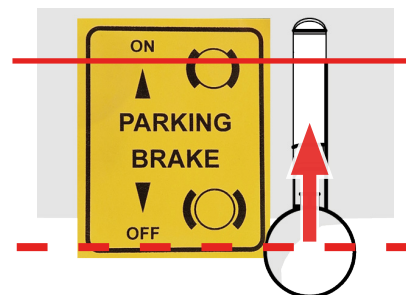

Fig.7A - Parking brake on.



Fig.7B - Engine switch on.

3. Operation and Emergency Procedures

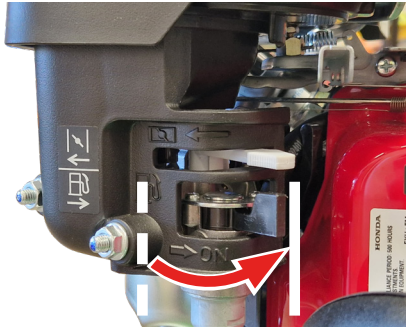

Fig.7C - Fuel lever open.

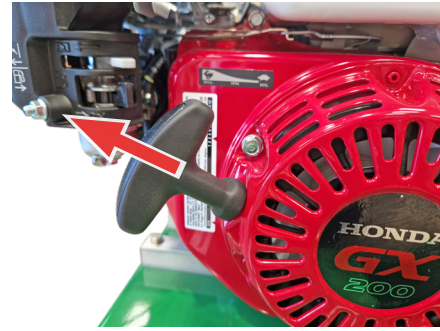

Fig.7G - Pull starter grip handle.

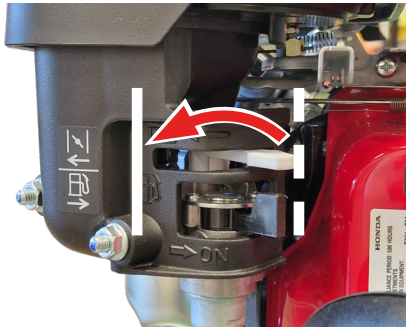

Fig.7D - Choke lever closed.

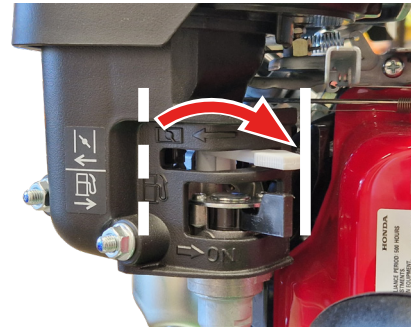

Fig.7H - Move choke lever into open position.

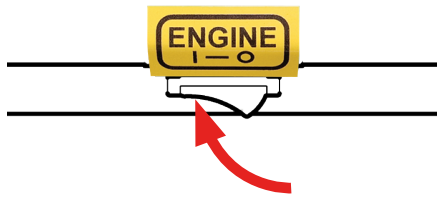

Fig.7E - Start switch on.



Fig.7F - Throttle set half-way

3.3. Stopping the Engine

To turn your machine *off*:

1. Move the throttle lever fully to the *low* (tortoise) position (Fig.8A).
2. Press the start switch (located with the control components) to the *off* position (Fig.8B).
3. Set the fuel lever to the *closed* position (towards the rear) (Fig.8C).

Fig.8 - Power off procedure

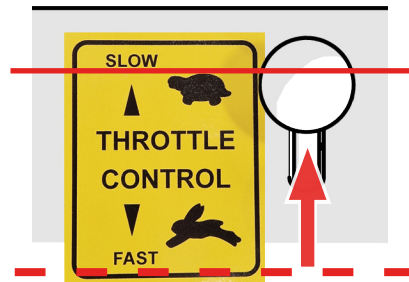

Fig.8A - Throttle set to low

3. Operation and Emergency Procedures

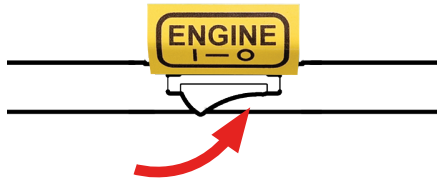

Fig.8B - Start switch off

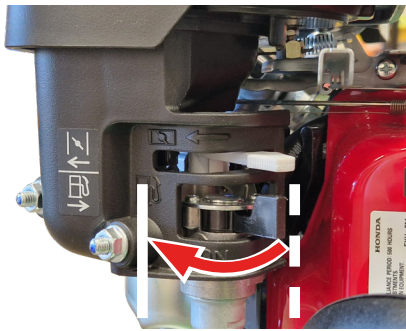

Fig.8C -

In emergency situations, turn either the start switch or engine switch to the **off** position.

3.4. Drive

3.4.1. Moving and Transport (no cut)



CAUTION - HANDLEBAR HEIGHT

Prior to moving the machine, set handlebar to the correct height. See "4.3.1. Handlebar Height Adjustment" p.47.

1. Start the engine as per "3.2. Starting the Engine" p.22.
2. Release the parking brake (**off** position).
3. Set the throttle to tortoise speed.
4. Push the Drive Lever **forwards** to **engage** drive (Fig.9A). Do this slowly to allow the clutch to ease into position.
5. Adjust the Throttle Lever to increase speed if desired (Fig.9B).
6. To **stop**, pull the Drive Lever towards the rear to the 'disengage' position (Fig.9C)



NOTE - ENGINE STOP

Depressing the OPC while keeping the park brake on will result in the engine stopping. Following the order above will stop this happening.



NOTE - DRIVING OVER HARD GROUND

When travelling over surfaces other than grass, tilt the machine backward to elevate the front roller, ensuring it travels solely on its rear roller. This avoids potential damage to the cassette and blades.

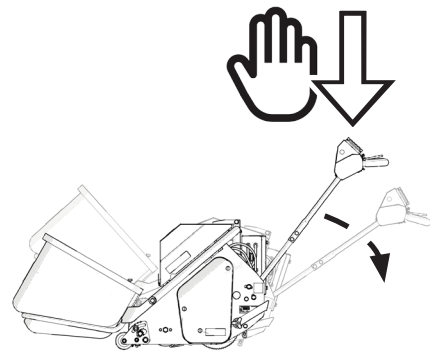

Fig.9 - Driving procedure

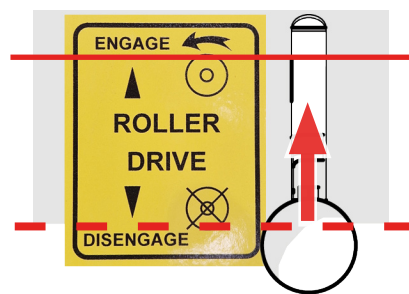

Fig.9A - Engage the drive lever.



Fig.9B - Adjust the throttle lever.

3. Operation and Emergency Procedures

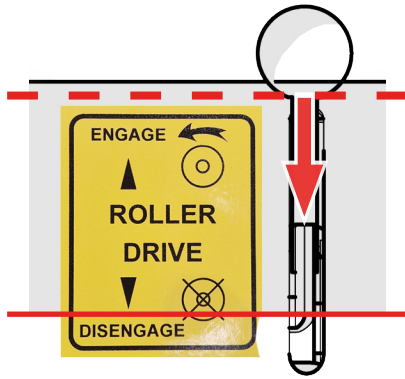

Fig.9C - Disengage the drive lever.

3.4.2. Moving (with cut/scarify/brush)



NOTE - HEIGHT OF CUT

Prior to cutting, set the cassette to the correct height. See "3.5.2. Adjusting Height of Cut (Cylinder)" p.28.

1. Start the engine as per "3.2. Starting the Engine" p.22.
2. Release the parking brake (off position).
3. Set the throttle to tortoise speed.
4. Depress the OPC (Fig.10A).
5. Push the Cassette Lever **forwards** to **engage** the cassette. Do this slowly to allow the clutch to ease into position (Fig.10B).
6. Push the Drive Lever **forwards** to **engage** drive. Do this slowly to allow the clutch to ease into position (Fig.10C).
7. Adjust the Throttle Lever to increase speed if desired (Fig.10D).
8. To **stop moving**, pull the Drive Lever towards the rear to the 'disengage' position - the cassette will continue to spin if the OPC is also depressed (Fig.10E).
9. To **stop the cassette spinning**, pull the Cassette Lever towards the rear to the 'disengage' position. Alternatively, release the OPC (Fig.10F).

Fig.10 - Cutting procedure

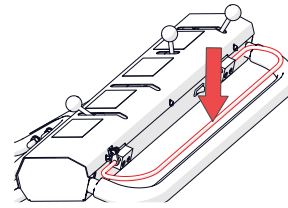

Fig.10A - Depress the OPC.

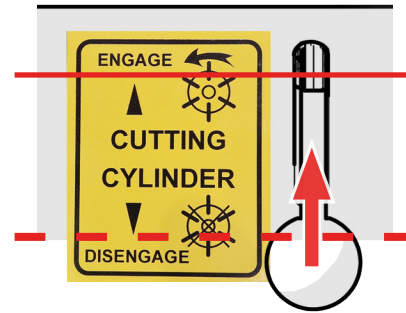

Fig.10B - Engage the cassette lever.

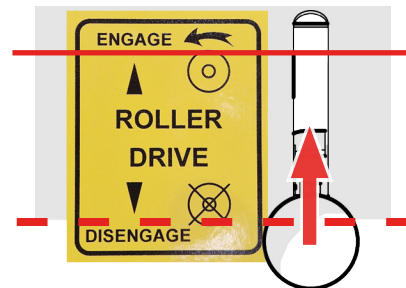

Fig.10C - Engage the drive lever.



Fig.10D - Adjust the throttle lever.

3. Operation and Emergency Procedures

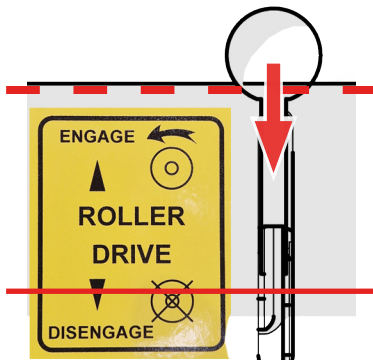

Fig.10E - Disengage the drive lever.

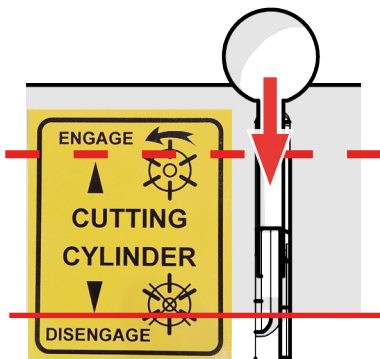

Fig.10F - Disengage the cassette lever.

3.4.3. Operating on Slopes



The machine operates best on flat ground. Follow the safety points below when operating on slopes:

- Slopes can tip a machine over. Observe extreme caution. Check for obstacles or anything that may lead to instability (e.g. dips, bumps, uneven ground) prior to operating.
- There is no maximum operating machine slope angle; use personal judgement, taking into account surrounding environment and weather. If in any doubt, do not use on a slope.
- Operate across the face of a slope, never up and down.
- Avoid when wet as this can increase the risk of an accident occurring.



WARNING - SLOPES

- Go slow; speed can increase the risk of an accident occurring. Take extra care when turning.

3.5. Cutting Preparation



WARNING - CASSETTE SAFETY

- Always turn the engine off before removing/inserting the cassette. Failure to do so creates a very high risk of cutting or damaging hands. Always wear hand protection.
- The cassettes are heavy - see "2.5. Cassettes" p.19 for more information. We recommend for two people to remove.

3.5.1. Removing and Inserting a Cassette

Tools required:

- 19 mm spanner
- 24 mm spanner

1. Turn the engine off.
2. Remove the grassbox and fold the frame up.
3. Loosen the cassette retaining bolt locknut [24 mm spanner] (Fig.11A) and unscrew the retaining bolt [19 mm spanner] (Fig.11B) until the pip end is inside the nut on the side frame.
4. Slide the cassette along the tie-bars towards the R/H side of the machine. The L/H of the cassette will be clear of the three pins of the drive coupling (~15 mm) (Fig.11C).
5. From the front of the machine, hold onto the cassette handle and remove by a lift-and-swing motion, from the back to the front. ⚠ We recommend two people to help with this (Fig.11D).

3. Operation and Emergency Procedures

- 6. To insert a cassette: Lift the cassette using the handle and lower the front slots of the cassette unit onto the front tie-bars. Slowly lower the back end onto the back tie-bars.
- 7. Slide the cassette to the L/H of the machine until there is full engagement with the three pins of the drive coupling (Fig.11E). The cylinder may need slight manual rotation to align with the pins. ⚠
- 8. Tighten the retaining bolt [19 mm spanner] (Fig.11F) and then the locknut [24 mm spanner] (Fig.11G).
- 9. Normal use can now be resumed.

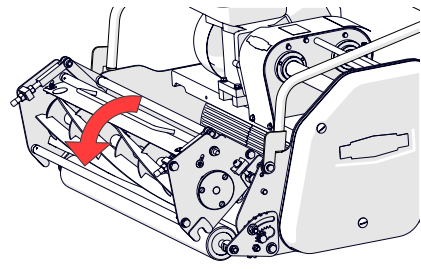

Fig.11D - Lift the cassette out

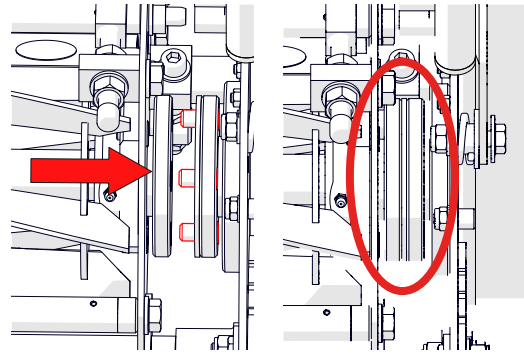

Fig.11E - Lower the new cassette in and slide across, engaging with three pins.

Fig.11 - Removing and Inserting a Cassette

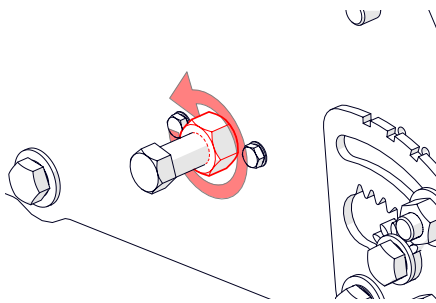

Fig.11A - Loosen retaining bolt locknut

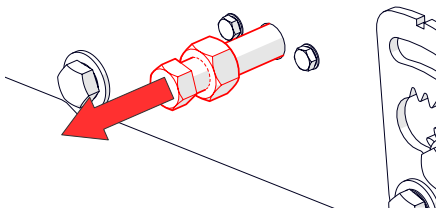

Fig.11B - Unscrew retaining bolt

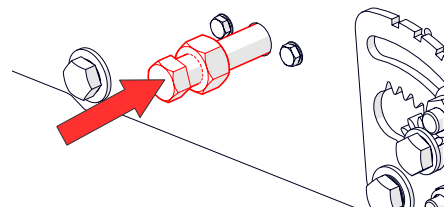

Fig.11F - Secure the retaining bolt

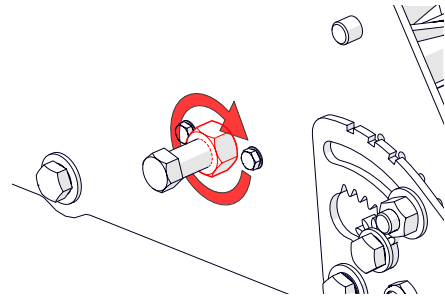

Fig.11G - Secure the locknut

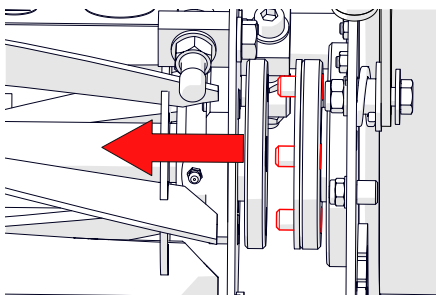

Fig.11C - Slide cassette until pins are visible

3. Operation and Emergency Procedures

3.5.2. Adjusting Height of Cut (Cylinder)

The following procedure is for adjusting the height of cut for the cylinder cassettes only. For other cassettes, see "3.5.3. Adjusting Height of Cut (Scarification, Dethatching and Brushing)" p.30.

Tools required:

- 19 mm spanner
- Rule
- Setting bar

1. Turn the engine off (Fig.12A).
2. Remove the grassbox and fold the carry frame up.
3. On the setting bar, adjust the bolt against the rule until the distance between the base of the bolt head and rule is that of the desired grass length. Secure with the nut [19 mm spanner] (Fig.12B).
4. Tip the machine gently back so it rests on the rear roller and handlebar (Fig.12C).
5. Two positions along the cassette are required to be measured and adjusted to result in an even cut. Choosing either end of the cassette first, lay the setting bar across the front and rear roller. Correct height is achieved when the underside of the bolt head rests, or is level with, the lip of the shear blade (Fig.12D). If it already is, then no further adjustment is needed. If not, then continue with step 6.
6. Loosen the top clamp nut of the roller quadrant [19 mm spanner] (Fig.12E). Repeat on the opposite side quadrant.
7. Rotate the toothed gear to raise or lower the front roller. While doing this, position up the setting bar again between the front and rear roller. Stop adjusting when the head rests within the lip of the shear blade (Fig.12F). Tighten lightly the top clamp nut.
8. Repeat step 7 for the second position on the other side of the cassette (Fig.12G).
9. Check the setting bar again for both sides.

Adjust if necessary. Once at the desired height, tighten both top clamp nuts.

10. Lift the machine gently up to rest on its front and rear rollers. Unfold the grass box carry frame and return the grass box.
11. Normal use can now be resumed.



NOTE - HEIGHT OF CUT

- If planning on adjusting the shear blade at the same time, always adjust the shear blade first then adjust the height of cut. Doing the opposite way may result in a different height of cut than planned.
- From the factory, the machine is set to cut mid-height.
- Remember height of cut is affected by moisture of turf, weight of the machine and thatch density. We advise to set the height a little higher than your preference and reduce height by trial.

Fig.12 - Adjusting Height of Cut

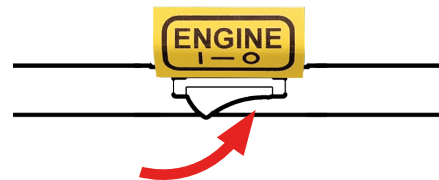

Fig.12A - Turn the machine off.

3. Operation and Emergency Procedures

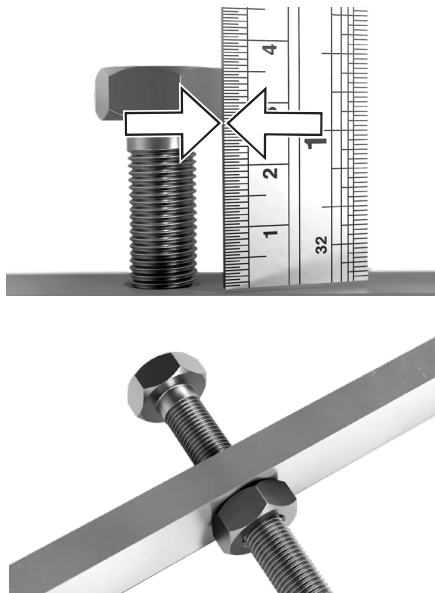

Fig.12B - Adjust bolt to desired cut height and secure nut (above example set for 27 mm)

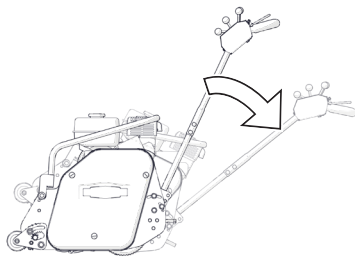

Fig.12C - Gently tip the machine back

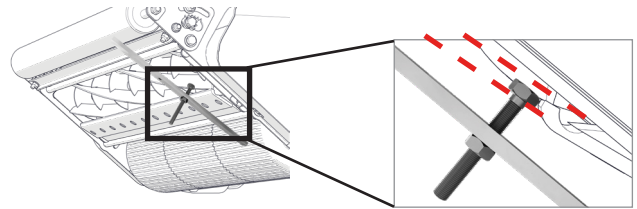

Fig.12D - Position the setting bar and observe distance between the top of the shear blade and bottom on the bolt head. In this example, the bolt head is below the shear blade, indicating the machine cut height is currently too high and therefore needs lowering.

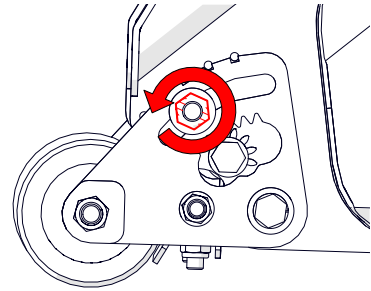

Fig.12E - Loosen the top clamp nut of the roller quadrant

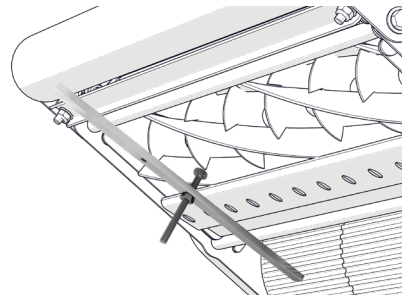

Fig.12G - Repeat process on the other side

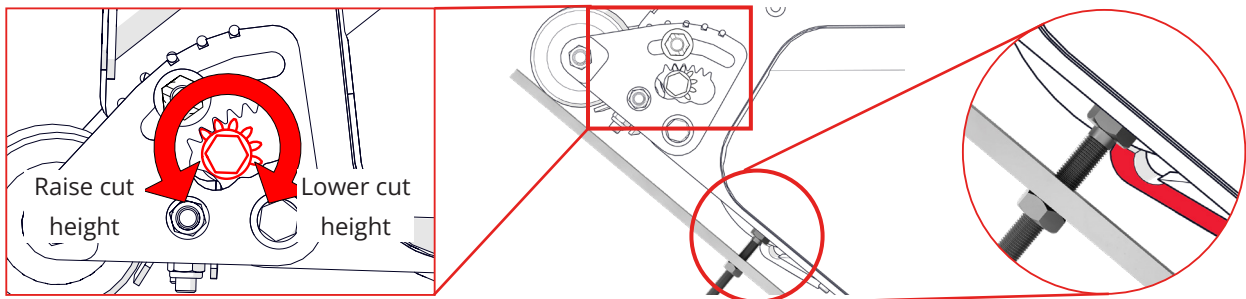

Fig.12F - Rotate the toothed gear while offering up the setting bar. Stop when the head rests level/within the shear blade

3. Operation and Emergency Procedures

3.5.3. Adjusting Height of Cut (Scarification, Dethatching and Brushing)

The following procedure is for adjusting the height of cut for the scarifying, dethatching and brushing cassettes. For cylinder cassettes, see "3.5.2. Adjusting Height of Cut (Cylinder)" p.28.

Tools required:

- 19 mm spanner
- Rule
- Setting bar

1. Turn the machine off (Fig.12A).
2. Remove the grassbox and fold the carry frame up.
3. On the setting bar, adjust the bolt against the rule until the distance above or below the setting bar (to the head or end, respec-

tively) is to that desired (Fig.13). To note:

- Brush/Verti-cutter/Spring-tine rake = Measure from top side of setting bar **up**.
- Scarifier/Sorrel roller = Measure from top side of setting bar **down**.

Secure the bolt height with the nut [19 mm spanner].

4. Tip the machine gently back so it rests on the rear roller and handlebar (Fig.12C).
5. Two positions along the cassette are required to be measured and adjusted to result in an even brush/verti-cut/scarify. Choosing either end of the cassette first, lay the setting bar across the front and rear roller (Fig.11D). Correct height is achieved when either the tips of the brush hairs/verti-cutters are level with the bolt head, or the

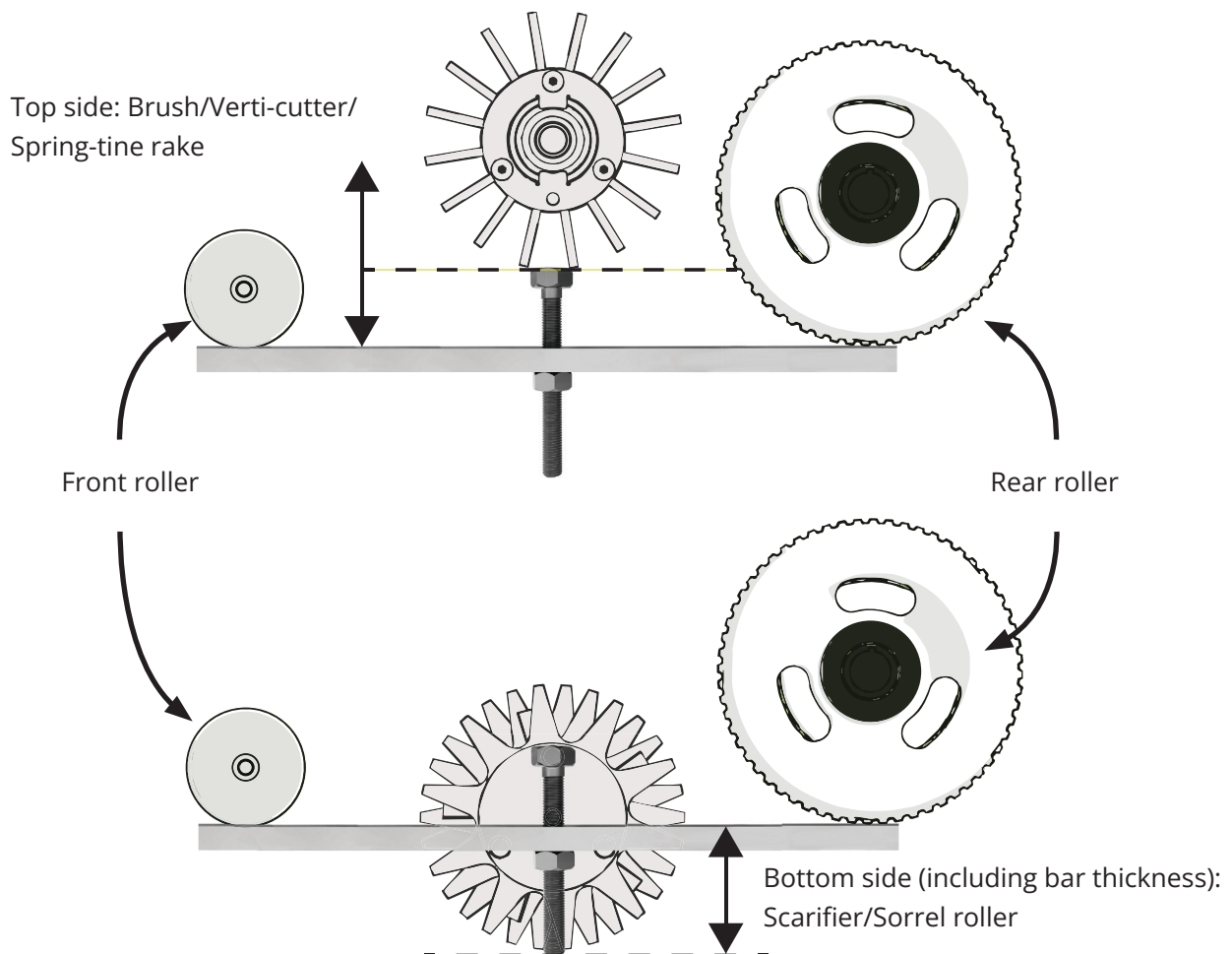

Fig.13 - Setting bar measurement for above/below ground cassettes.

3. Operation and Emergency Procedures

- tips of the scarifier/sorrel roller are level with the bolt end. If it already is, then no further adjustment is needed. If not, then continue with step 6.
- Loosen the top clamp nut of the roller quadrant [19 mm spanner] (Fig.121E). Repeat on the opposite side quadrant.
 - Rotate the toothed gear to raise or lower the front roller. While doing this, position up the setting bar again between the front and rear roller. Stop adjusting when either the tips of the brush hairs/verti-cutters are level with the bolt head, or the tips of the scarifier/sorrel roller are level with the bolt end. (Fig.13). Tighten lightly the top clamp nut.
 - Repeat step 7 for the second position on the other side of the cassette (Fig.12G).
 - Check the setting bar again for both sides. Adjust if necessary. Once at the desired height, tighten both top clamp nuts.
 - Lift the machine gently up to rest on its front and rear rollers. Unfold the grass box carry frame and return the grass box.
 - Normal use can now be resumed.
- Avoid cutting more than one third of the grass blade. Doing so can increase the risk of disease and stress for the plant.

3.5.4. Cutting Technique

There is no set technique for cutting as it will suit individual circumstances. However we recommend the following:

- Mow in straight lines - turning while cutting may damage the turf and produce an inferior quality of cut.
- To perform a turn, press the handlebar down to lift the front of the machine before applying force to the left/right side. The three part differential rear roller allows for easier and tighter turning.
- Mow at a standard walking space - alter the throttle speed accordingly to achieve this.
- Do not cut for too long in a single spot or without cutting grass. This can damage the grass and increase blade wear.

3. Operation and Emergency Procedures

3.6. Engine

3.6.1. Safety Information



Follow the engine guidance below to avoid damage and injury risk:

- **Always** refer to the OEM Operator's Manual for definitive engine instructions - it contains additional important information not given in this manual. Reference to the engine in this document is intended solely as supplementary information to support machine operation.
- **Flammable risk - Always** store fuel in specifically designed containers and handle correctly. Store the fuel in a suitable environment and use PPE when handling it.
- **Always** use regular unleaded petrol only (pump octane rating 86 or higher). Using the wrong fuel can damage the engine.
- **Always** keep maintained as per "4.1. Maintenance Schedule" p.36. This includes checking oil levels and leaks, keeping air filters clean and removing all debris blockages.
- **Always** operate outdoors or in a well ventilated area.
- **Always** add fuel before starting the engine. **Never** add while it is running.
- If fuel is spilt, move the machine a safe distance away and clean up the spill before starting the engine up.
- **Always** keep children and unauthorised personnel away from this unit.
- **Never** attempt to disassemble, repair or modify the engine.
- **Never** place anything on the engine due to fire risk.



- Allow the engine to idle for a short time before driving, especially in cold weather.
- The exhaust system/muffler becomes very hot and remains hot long after use. Be careful not to touch while still hot and allow to cool before transporting or storing indoors.
- Do not open, puncture, crush, incinerate, immerse in water, or tamper the engine in any way. Risk of fire or explosion.

3.6.2. Refuelling

Note the following for correct and safe refuelling use:

- Turn off the engine and allow it to cool before refuelling.
- Avoid smoking or using any ignition sources near the refuelling area.
- Refuel outdoors or in a well ventilated area.
- Only refuel using unleaded petrol (pump octane rating 86 or higher).
- Fill to no further than the neck of the tank.

3.6.3. Installation and Removal

The engine is supplied mounted to the chassis on engine bearers. During normal use, there is no expectation to remove the engine. However, if the engine is required to be removed entirely:

1. Turn the machine **off** from both the start switch (located with the control components) and the engine on/off switch.
2. If the engine is being removed permanently, remove all fuel and oil with a siphon pump

3. Operation and Emergency Procedures

or similar. If the engine is being removed temporarily, ensure the fuel cap and oil plug are secure.

3. Remove the 4 x M8 hex bolts securing the engine to the engine bearings [13 mm spanner].
4. Slide the engine towards the right hand side of the machine - this will disconnect the engine coupling from the driveshaft.

3.6.4. Engine Specifications

For engine specification, see "2.1.2. Specification Table" p.12 and within the supplied OEM manual for the engine.

3.6.5. Replacement and Disposal

Should the engine require disposal, follow the points in "4.7. Disposal" on page 51.

3.7. Operating Environment

The machine has been designed to be used on fine turf and meeting the demands of day-to-day use. The following operating conditions shall also be observed:

<p>Temperature:</p> <p>-15°C to +40°C. Usage in the upper and lower limits of this range will affect performance and engine life. It will also have an impact on the quality of cut and subsequent issues*. Operators must take necessary precautions against temperature, such as sun protection and suitable clothing.</p> <p><i>*The machine can operate beyond the temperature range of the optimum for grass cutting. Grass is best cut between 10-30°C.</i></p>
<p>Humidity:</p> <p>30-70% RH. High humidity can lead to rust and corrosion on metal parts. It can also lead to fungal diseases on the grass after cutting.</p> <p>Low humidity can lead to wilting and browning of the grass after cutting.</p>

<p>Weather:</p> <p>Use in dry conditions. This avoids damage to engine components and traction hazards caused from slippery grass.</p> <p>Cutting wet grass leads to poorer cut quality, clumping and reduced collection into the grass bag. This results in additional cleaning of the machine .</p> <p>Compaction of the soil is more likely with wet weather.</p> <p>Operators must take necessary precautions against the weather, such as sun protection and suitable clothing.</p>
<p>Terrain/Slope:</p> <p>Ensure the ground is firm and preferably dry. Soft or wet ground can cause manoeuvrability problems. There is no maximum slope angle, however use professional judgement when using on slopes (see "3.4.3. Operating on Slopes" p.26.</p> <p>Free from obstacles and obstructions, including rocks, branches and debris.</p>
<p>Dust and particulate:</p> <p>Avoid dusty or sandy conditions. Such environments can damage the machine and be hazardous to the operator.</p>
<p>Vibration and Shock:</p> <p>Keep vibration and shock to a minimum to avoid damage to machine components. This includes, bumps, pot holes and kerbs. Store the machine away from passing traffic and avoid transporting over rough ground - lower gently over kerbs or use alternative routes.</p>
<p>Lighting Conditions:</p> <p>Use the machine in good lighting conditions, either natural or artificial. This allows for the safe operation of the machine.</p>
<p>Safety Zones:</p> <p>Other than the operator, all other personnel must keep their distance from the machine during use. This must be maintained by the operator to keep the zone free.</p>

3. Operation and Emergency Procedures

3.8. Emergency Procedures

3.8.1. In the Event of a Breakdown



- Take full care and attention while investigating the cause of a fault. Where possible, wear suitable PPE including gloves and safety glasses.
- Never touch leaked materials, avoiding contact with skin and eyes. Rinse immediately with water and seek medical attention if necessary.
- Secure the working area with appropriate warning notices.
- In case of a petrol spill, clean it up immediately using appropriate absorbent materials.

Regular service and maintenance will prevent the majority of machine breakdowns. The below procedure outlines the immediate actions if the machine fails to function entirely. If the machine is not working as intended and a minor issue, refer to "4.8. Troubleshooting & FAQ" p.52.

In the event of a breakdown:

1. Turn the machine **off** and turn the switch located on the engine to **off**.
2. Disconnect the spark plug by holding between the thumb and fore-finger and pulling away. This prevents accidental engine starting.
3. If possible, move the machine to a safe area where further investigation can be carried out. If the machine cannot be moved, clearly label it as 'faulty' and cordon around the machine to mitigate unauthorised personnel from accessing the machine.
4. If there are fuel leaks, immediately clean up and adsorb with appropriate materials.
5. Once in a safe area or in a serviceable state,

inspect the machine for any obvious defects. Do not attempt repairs beyond basic troubleshooting unless qualified. Full repairs to be carried out by qualified service engineer and documented accordingly.

6. If the source of the breakdown cannot be found, contact your Dealer or Howardson Group for further information.

3.8.2. Hazardous Substances and Fire



- Always operate and refuel the lawnmower outdoors or in well-ventilated areas - never operate the engine in enclosed spaces. Avoid inhaling exhaust fumes.
- Wear appropriate PPE when handling petrol, such as gloves and safety glasses.
- Dispose of petrol and contaminated materials in accordance with local regulations.

When operating the lawnmower, the combustion of petrol in the engine produces several emissions that may be hazardous to health and the environment. This includes predominantly:

- Carbon Monoxide (CO): A toxic, odourless gas that can cause dizziness and headaches,
- Nitrogen Oxides (NO_x): Can irritate the respiratory system,
- Other emissions include Carbon Dioxide (CO₂), unburned hydrocarbons, particulate matter and Volatile Organic Compounds (VOCs).

Operating outdoors or in well ventilated area will reduce this risk.

3. Operation and Emergency Procedures



WARNING - HANDLING PETROL AND FIRE PREVENTION

Note the following when working and handling petrol:

- Always use approved containers for petrol storage.
 - Store petrol in a cool, well-ventilated area away from open flames or sparks.
 - Avoid overfilling the fuel tank to prevent spills.
 - Keep the area immediately around the engine and exhaust free of grass and debris to prevent fire hazards.
 - Regularly inspect the machine for fuel leaks. Repair any found immediately and prior to use.
-

In the event of a fire involving the machine or fuel:

- Stop the engine immediately (if safe to do so).
- Evacuate the area and ensure all persons are at a safe distance.
- Do not attempt to move the machine if it is on fire.
- Call Emergency Services if the fire cannot be quickly and safely controlled.
- Use a Class B fire extinguisher, which is designed for flammable liquids such as petrol.

Important: Only attempt to extinguish the fire if you are trained and it is safe to do so. Personal safety must always come first.

4. Maintenance and Service

4.1. Maintenance Schedule



Following the schedule set out below will prolong the life of your machine and deliver high performance.

Failure to carry out these checks at the specified intervals will result in damage to your machine and possible injury to personnel. If you are unsure of anything, contact Howardson Group or your Dealer.

Not servicing your machine correctly will invalidate your warranty. See "4.9. Warranty Policy" p.53 for more information.

Always use genuine Dennis/Honda parts when servicing and replacement.

The following checks must be actioned as per date, running hours or distance, whichever comes first. Ensure checks are performed in an appropriate area (such as a storage shed), and not on the playing surface due to risk of containments/petrol/oil. Complete checks with the engine *off* and when following 'Post-use', check only when the engine has cooled.

Checks regarding the petrol engine must be in conjunction with the maintenance items in the OEM manual. Where maintenance intervals differ, always follow the more frequent schedule to ensure optimal performance and warranty compliance.

Service kits are available for the machine - see "Appendix B. Service Kit" p.55.

Maintenance and Safety Checks	Daily		Monthly 150hr 480km	6-monthly 900hr 2,880km	Annually 1800hrs 5,760km
	Pre-use	Post-use			
Controls					
Check the following for signs of damage and that they operate freely and as intended: <ul style="list-style-type: none"> • OPC • Start switch • All 'Control Component' levers by handlebar (x4): <ul style="list-style-type: none"> ◦ Parking brake operates brake caliper. ◦ Throttle lever moves the throttle control lever on the engine. ◦ Drive and Cassette Levers both operate their respective clutches. 	•	•	•	•	•
Set the parking brake to <i>on</i> . Depress the OPC and try to start the engine - the engine must not start.	•		•	•	•
Operate the OPC (engine off), ensure the 'click' is heard from its microswitch.	•		•	•	•

4. Maintenance and Service

Maintenance and Safety Checks	Daily		Monthly 150hr 480km	6-monthly 900hr 2,880km	Annually 1800hrs 5,760km
	Pre-use	Post-use			
With the engine running, tip the machine back slightly so the cassette is raised above the ground. Depress the OPC and then engage the cassette. Release the OPC - the cassette <i>must</i> stop. If it does not, see " 4.8. Troubleshooting & FAQ " p.52.	•		•	•	•
Chassis					
Check all guards are fitted correctly.	•		•	•	•
Visually check all fixings (secure and in place).	•		•	•	•
Visually check condition of shear blade.	•		•	•	•
Check the cutting height is set correctly.	•		•	•	•
Check the grass box is fitted correctly.	•		•	•	•
Clean off all grass cuttings from bodywork.		•	•	•	•
 Clean off all grass cuttings from the cassette blade/disc (ensure the machine is turned off first. Use a long handled brush).		•	•	•	•
Grease ¹ rear roller (located under the belt guard near rear roller pulley).		•	•	•	•
Remove belt guard and visually check condition of drive belts. Adjust/change if required.			•	•	•
Apply a small amount of grease to shear blade adjuster rods.			•	•	•
Check rear roller bushes and bearings for wear.				•	•
Lubricate front roller pivot bushes.				•	•
Renew oil in rear rollers ²					•
Replace all drive belts.					•
Engine					
Check engine oil level.	•				
Check air filter.	•				
Check fuel level is enough for intended use (do no overfill past the neck). Clean all grass/debris around the neck first to avoid contaminating the fuel.	•				
Check condition of the entire engine (including driveshaft guards) following for signs of damage. Do not use if anything is damaged.	•	•	•	•	•

4. Maintenance and Service

Maintenance and Safety Checks	Daily		Monthly 150hr 480km	6-monthly 900hr 2,880km	Annually 1800hrs 5,760km
	Pre-use	Post-use			
Clean off all grass cuttings/debris from the entire engine using an air-hose, brush or similar. This includes: fuel tank, air filter, starter grip and exhaust. Failure to clean will increase fire risk.	•	•	•	•	•
Change engine oil (20 hours first change).			•	•	•
Clean sediment cup.			•	•	•
Check/clean spark plug.			•	•	•
Remove air filter cover and clean debris from base of filter.			•	•	•
Remove air filter cover and remove outer foam filter and wash in warm, soapy water. Ensure thoroughly dry before returning. Replace if damaged.			•	•	•
Remove air filter cover and clean debris from around the paper filter by tapping several times on a hard surface. Replace if excessively dirty or damaged.			•	•	•
Check/adjust valve clearance*.				•	•
Clean fuel tank and strainer*.				•	•
Check fuel line. Replace if necessary*.	Every two years				
Cassette 					
Check the blades/discs spin freely, with no grinding or metal-on-metal contact noises (<i>always</i> turn the machine <i>off</i> first).	•	•	•	•	•
Check for wear or damage (impact, dents, material cracking and excessive thinning).	•	•	•	•	•
Check the retaining nut is tight and secures the cassette.	•	•	•	•	•
Grease ¹ cylinder bearings (x2).		•	•	•	•
Check the cassette can be removed and replaced easily.			•	•	•
Check the three pins of the drive coupling engage with the cassette.			•	•	•
Replace worn or damaged blades/discs.				•	•

¹ Use multipurpose lithium EP2 grease

² Use oil grade EP90

*Authorised Honda dealer or mechanically proficient only.

4. Maintenance and Service

4.2. Servicing Instructions



WARNING - SAFETY

- You **must** turn the machine **off** before service work. Failure to do so may cause major injury.
- Always wear suitable PPE for the job at hand.



CAUTION - SERVICE LOCATION

When servicing the machine, position in a suitable environment for working on (for oil spills etc) and if planning leaving for extended periods.

4.2.1. Cassette and Drive Belt Replacement/ Tensioning



CAUTION - BELT TENSIONING

Incorrect tensioning of a belt can lead to a range of issues and premature failure of components. Issues include slippage (resulting in poor power transmission), increased component wear, increased noise, increased stress on bearings and pulleys, pulley damage and many others.

New belts will stretch during the first hours of use and must be monitored regularly. Inspect after ~30 minutes to four hours operating under full load and re-tension accordingly.

After approximately 24 hours of operation, inspect and re-tension again.

Tools required:

- Slotted screwdriver
- 10 mm spanner
- 17 mm spanner
- 9/16" spanner
- Belt tensioner gauge

- Replacement belt (*if required, cassette belt p/n 228030 (x2), drive belt p/n 228012*)

1. Turn the machine **off** and disengage both drive and cassette levers (Fig.13A).
2. Remove 3 x outer screws of the belt guard [slotted screwdriver] (Fig.13B) and keep the cover to the side.
3. Cassette Belt:
 - i. If re-tensioning only, skip to step iv. Remove the semi-circular belt guide by removing the two M6 bolts [10 mm spanner] (Fig.13C).
 - ii. Hold the tensioner pulley away. Remove the belts and replace (Fig.13D).
 - iii. Refit the belt guide but do not tighten.
 - iv. Engage the cassette lever (Fig.13E) - the tensioner pulley will make contact with the belts and put them under tension. Adjust the cable and lever to achieve more or less tension on the belts. Correct tension is achieved that when the upper pulley is turned (by hand), the belt moves and turns the lower pulley accordingly (Fig.13F). When the cassette lever is disengaged, the tensioner pulley must 'rest' on the belt and not provide any form of pressure (turning of the pulley does not result in the belt moving).

4. Maintenance and Service

  **WARNING - GUIDE PEG CONTACT**

When in the *engaged* position, the tensioner pulley must *not* make contact with the guide peg (circled). See "4.3.3. Guide Peg Adjustment" p.49 for more information.

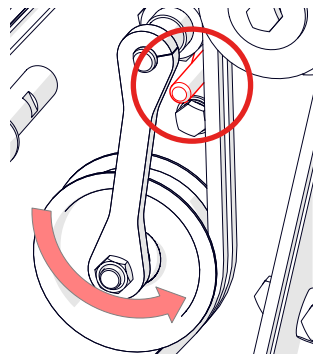

4. Drive Belt:

- i. If re-tensioning only, skip to step iii. Loosen the tensioner pulley [9/16" spanner] (Fig.14G).
- ii. Hold the tensioner pulley away. Remove the belt and replace (if required) (Fig.14H).
- iii. Adjust the tensioner pulley to add tension to the belt and tighten. Tension is tested by twisting the belt between thumb and forefinger. Achieve a twist between 70–90° (Fig.14I), or 350N with a belt tensioner gauge. Re-adjust the tensioner pulley if necessary, making more or less contact to achieve these values.

5. Attach the belt guard [slotted screwdriver].
6. The machine is now ready for use.

Fig.14 - Drive belt replacement / tensioning

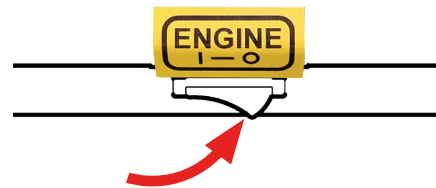

Fig.14A - Turn the machine off.

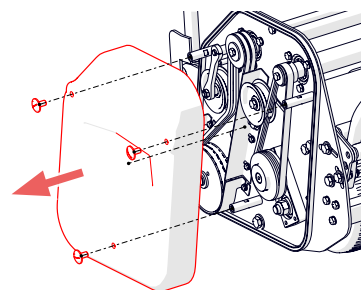

Fig.14B - Remove 3 x outer screws and cover.

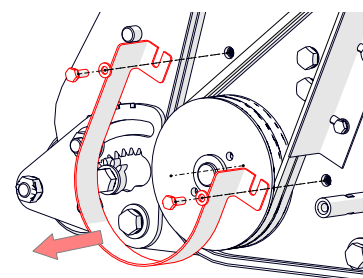

Fig.14C - Remove the belt guide.

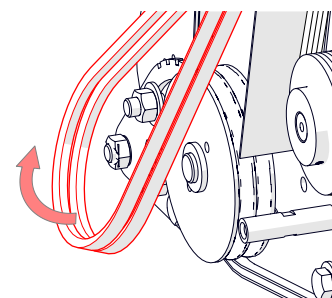

Fig.14D - Remove and replace the belt.

4. Maintenance and Service

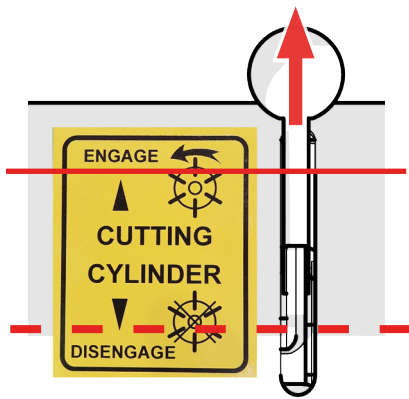

Fig.14E - Engage the cutting lever to apply tension.

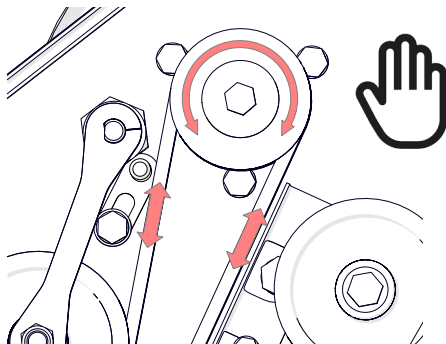

Fig.14F - Check correct tension by moving the pulley by hand.

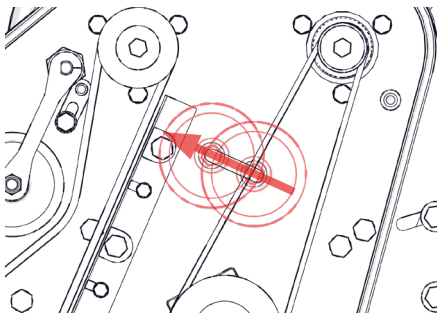

Fig.14G - Loosen the tensioner pulley.

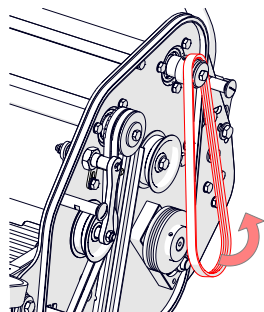

Fig.14H - Remove and replace the belt.

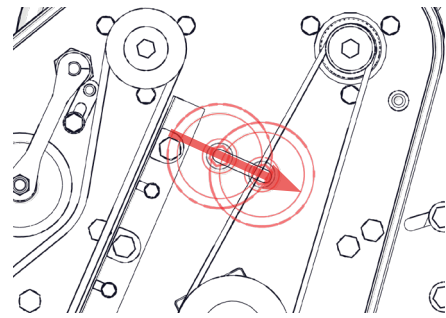

Fig.14I - Adjust the pulley to add pressure to the belt.



Fig.14J - Correct pressure achieved when the belt twists 90°.

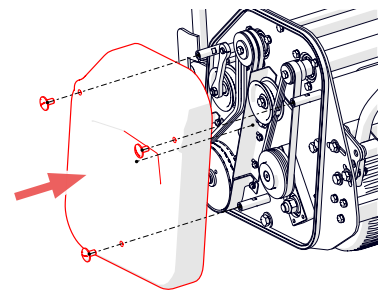

Fig.14K - Reattach cover.

4. Maintenance and Service

4.2.2. Transmission Belt Replacement/ Tensioning

Tools required:

- 10 mm spanner
- 13 mm spanner
- 24 mm spanner
- Replacement belt (*if required, belt p/n 228007*)

1. Turn the machine **off** and disengage both drive and cassette levers.
2. Remove the 4 x M8 bolts securing the transmission guard [13 mm spanner] (Fig.15A).
3. Remove the 4 x M8 hex bolts securing the engine to the engine bearings [13 mm spanner] (Fig.15B).
4. Check the fuel cap and engine oil plug are secure. Slide the engine towards the right hand side of the machine and remove safely to the side (Fig.15C).
5. Remove the 2 x M6 bolts securing the semi-circular belt guide [10 mm spanner] (Fig.15D).
6. Remove the brake disc [24 mm spanner] (Fig.15E).
7. Remove the belts and replace (if required) (Fig.15F).
8. Reassemble the brake disc [24 mm spanner] and belt guide [10 mm spanner].
9. Adjust the pulley so when the drive lever is in the disengaged position, it rests on the support bracket (Fig.15G), avoiding as much contact with the belt as possible.
10. Engage the drive lever. Ensure that when the output shaft is turned (manually), the belt moves and turns the drive shaft pulley (Fig.15H). Adjust the tension of the cable and arm to achieve this.
11. Disengage the drive lever. Reinstall the engine by aligning the coupling of the output shaft and engine bearer bolt holes.

12. Secure the engine to the engine bearings [13 mm spanner].

13. Reinstall the transmission guard [13 mm spanner].

14. The machine is now ready to use.

Fig.15 - Handlebar adjustment

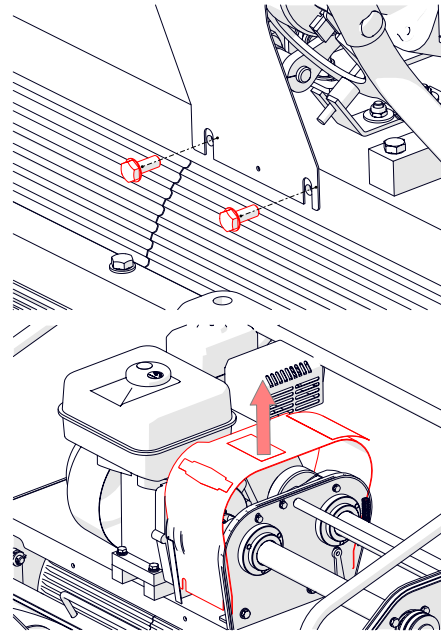

Fig.15A - Transmission guard removal.

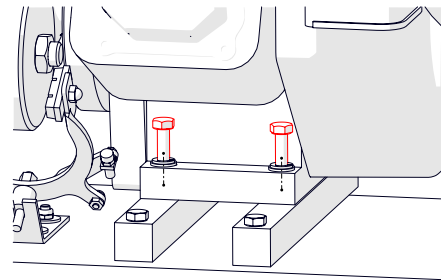

Fig.15B - Remove engine bolts from bearers.

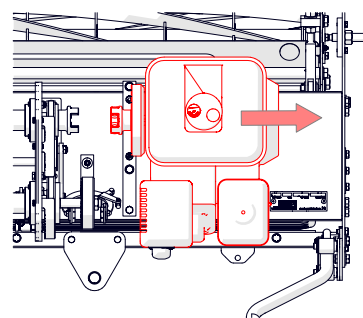

Fig.15C - Slide engine away from coupling.

4. Maintenance and Service

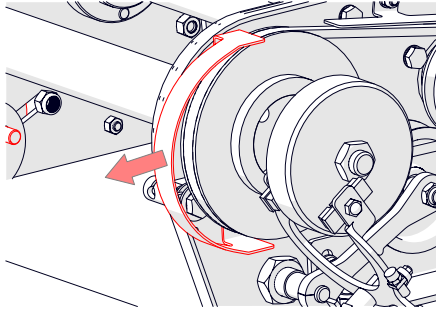
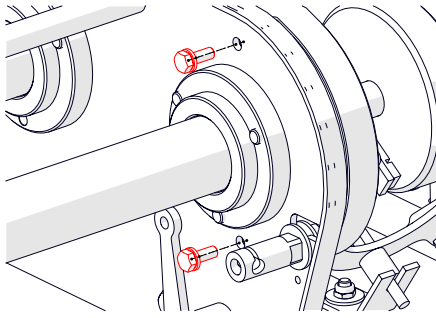

Fig.15D - Remove bolts for belt guide.

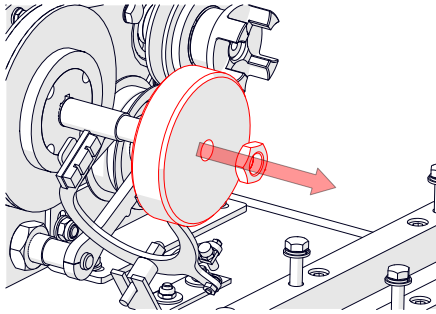

Fig.15E - Remove brake disc.

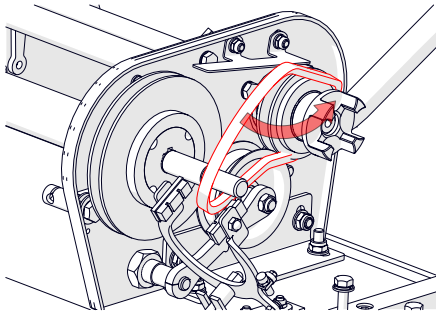

Fig.15F - Replace drive belt.

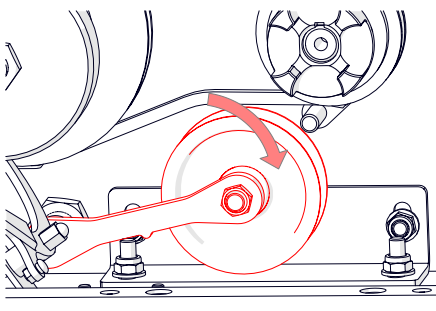

Fig.15G - Adjust the pulley to avoid belt contact in disengaged state.

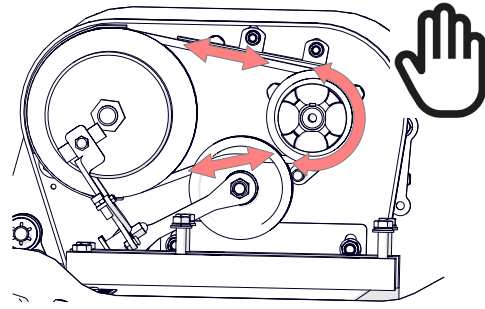

Fig.15H - Check correct tension by moving the pulley by hand.

4.2.3. Backlapping

Cutting blades will become blunt over time, producing an inferior quality of cut. Backlapping is the method of sharpening both the cylinder and shear blade simultaneously using a grinding compound while manually running the drive in reverse. This maintains a sharp edge on the blades to prolong their life, however it is not a substitute for a true grind. Do **not** backlap on damage blades or those beyond repair.

Grinding paste is required to achieve the sharpening of the blades. Three grit types are commonly available (80/120/220 grit) - the type chosen should be based on blade number, wear and expected use.

		WARNING - BACKLAPPING
		

- **Always** wear suitable PPE, including eye protection and gloves.
- **Always** use a long handled brush. This minimises risk of close contact with the spinning cylinder.
- Backlap in a suitable area where the paste can be washed away afterwards. The paste can splatter so ensure a distance is maintained around the machine.

4. Maintenance and Service

Tools required:

- Long handled brush
 - Back lapping paste
 - Backlap drive adaptor (p/n 229571)
 - Speed brace /drill (1/2" drive)
1. Turn the machine **off**. Remove the cassette from machine (see "**3.5.1. Removing and Inserting a Cassette**" p.26).
 2. On a level surface, place the cassette on its back, with the shear blade pointing upwards.
 3. Apply a small amount of grinding paste along the whole length of each blade using a long handled brush (Fig.16A).
 4. Insert the backlap drive adaptor into the cassette drive coupling.
 5. Using a suitable brace or drill, rotate the cylinder clockwise causing a grinding action with the shear blade (Fig.16B). This should be continued until a sharp lip is achieved on the leading edge of each cylinder blade. This may take a few minutes - stop periodically to check the edge and reapply paste as necessary.

Note: rotating the cylinder clockwise is opposite to the normal operation of the machine. This may cause the drive coupling to become unscrewed. If this occurs, chock the cylinder with a piece of wood or similar, and tighten the drive coupling [Left hand thread].
 6. When backlapping is complete, all grinding paste must be cleaned off the cylinder. This can be achieved with a low powered hose or a sponge and bucket of water. Failure to clean thoroughly will result in accelerated wear while cutting.
 7. Return the cassette to the machine. The machine will now need the shear blade adjusting to account for the change to the cylinder, "**4.3.2. Shear Blade Adjustment**" p.48.

Fig.16 - Backlapping

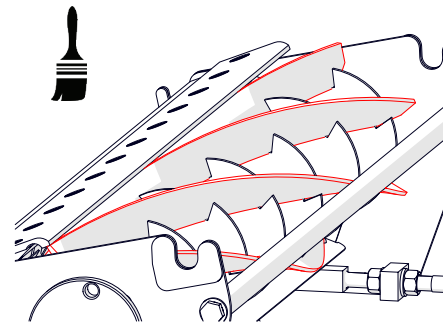

Fig.16A - Apply paste to the blades

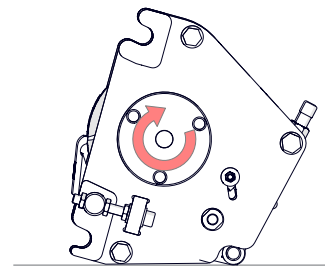

Fig.165B - Rotate the cylinder clockwise

4.2.4. Grinding Cutting Blades

Grinding, as with backlapping, restores the sharp edge of the blades, allowing for a clean, precise cut. Grinding is highly recommended to maintain optimal performance and extend the life of the cutting cassette. However unlike backlapping, this method creates an 'as new' sharp edge, rather than a temporary honed one.

Grinding is recommended when paper does not cut cleanly from the shear blade test (see "**4.3.2. Shear Blade Adjustment**" p.48), or when backlapping does not achieve the sharp edge required (usually caused by the edge being rounded too far beyond the capabilities of backlapping). Grinding can also help restore the cylindrical shape of the cylinder, which without, would be seen in poor grass cutting quality and streak marks.

Two grinding methods are performed on our cutting cylinders - spin and relief. As standard, all Dennis cutting cylinders are spun ground, with those of eight blades or more having an

4. Maintenance and Service

additional relief grind. Relief grinding is the process of removing material from the back of each cylinder blade to create a slight angle (i.e. the 'relief').

This relief angle produces a number of benefits:

- Improved cutting quality.
- Increased efficiency: Relief ground cylinders have been shown to reduce the power required to achieve a cut, thereby reducing fuel consumption. This is achieved from less friction between the cylinder and shear blade.
- Less wear between the cylinder and shear blade resulting in:
 - i. Longer blade life for both cylinder and shear blades.
 - ii. Less cylinder/shear blade adjustments.
 - iii. Less backlapping maintenance.
- Longer service life of adjacent moving parts, such as bearings and gears.

Factory standard relief grind is 50% land area at 30 degrees (see Fig.17). It is recommended to grind to these values.

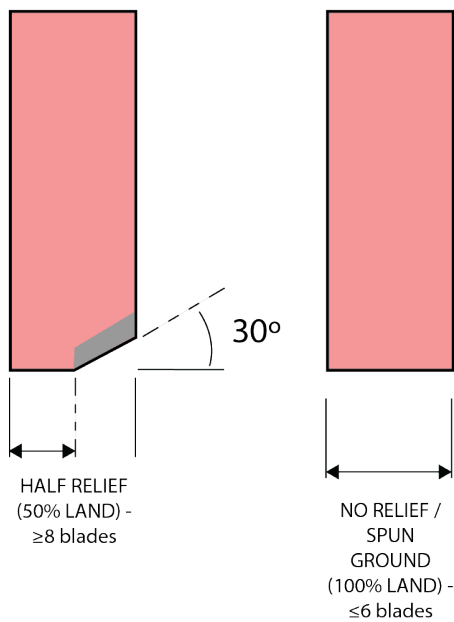

Fig.17 - Recommended cylinder grind angle

Shear blades also need to be ground, ideally at the same time as the cutting cylinder. It is important to include a relief grind as this helps present the grass at the correct height for cutting. Without this, using a flat or positive front angle can lead to inconsistent cutting heights and an uneven grass surface (see Fig. 19).

Factory standard is a front angle of -10° and top angle of -8° , as shown in Fig.18.

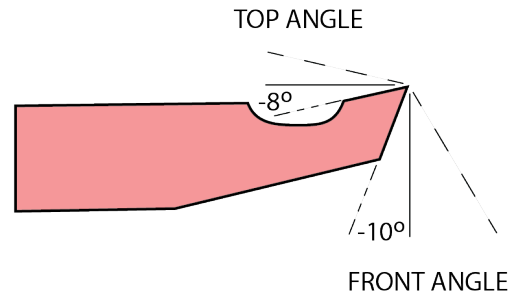

Fig.18 - Recommended shear blade grind angle

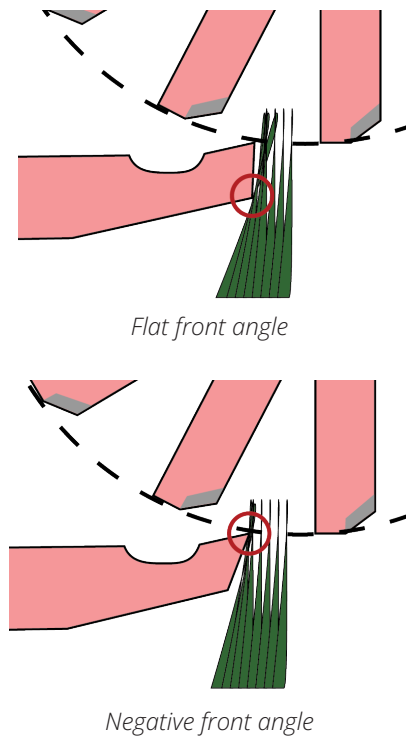

Fig.19 - Illustration of two different shear blade angles and their grass contact point

For any method of grind, you must use a professional grinding service or dedicated grinding machine. Failure to do this may result in a far inferior cut and increased risk of injury.

4. Maintenance and Service

4.2.5. Checking/Tensioning Parking Brake

Over time, wear and tear may reduce the parking brake effectiveness. If the following occurs when the parking brake is on then adjustment may be required:

- The machine moves under its own weight on a slope, or
- Can be easily pushed with minimal resistance,

Alternatively the brake may have been adjusted too tight and cannot be engaged.

Tools required:

- 10 mm spanner
 - 13 mm spanner
1. Turn the machine **off** and allow the engine to cool.
 2. Chock the front and rear rollers.
 3. Remove the transmission guard by loosening the 4 x M8 bolts [13 mm spanner] and lifting the guard upwards and away from the machine.
 4. Inspect the brake pads. If the wear indicator grooves are visible then replacement is not required. If the wear indicators are not visible, then replace with new before continuing to adjust tension.
 5. *Optional* - Remove the brake caliper [10 mm spanner] for easier access to park brake cable adjustment.
 6. Loosen the nut of the brake cable [10 mm spanner] and adjust the brake cable accordingly.
 7. Replace the brake caliper (if removed) and tighten.
 8. Operate the parking brake lever - it must engage fully and the brake hold the weight of the machine.

4.2.6. Changing Rear Roller Oil

To replace the oil in the rear roller:

Tools required:

- Lifting jack, raised platform or another method to raise the machine
 - Wooden chocks
 - 8 mm hex socket
 - Oil tray (volume >1.0 L)
 - Oil absorbent pads
 - Oil (grade EP90) - 0.5 L (G660), 0.6 L (G760), 0.7 L (G860)
 - Oil funnel and tube, or similar
1. Turn the machine **off** and allow the engine to cool.
 2. Chock the front rollers. Lift the rear of the machine enough to gain clearance for 8 mm hex socket and oil tray.
 3. Place oil absorbent pads down under the roller along with an oil tray.
 4. Rotate the central roller until the drain hole is pointing downwards (Fig.20A & Fig.20B).
 5. Remove the tapered plug [8 mm hex socket] and let the oil drain.
 6. Once fully drained, rotate the roller until the drain hole is pointing rearwards and above horizontal.
 7. Fill the roller with the correct grade and quantity of oil using the funnel/tube or similar.
 8. Insert the tapered plug. Remove the oil absorbent pads and trays and dispose of in a responsible manner.
 9. Lower the machine. The machine is now ready for use.

4. Maintenance and Service

Fig.20 - Rear roller oil

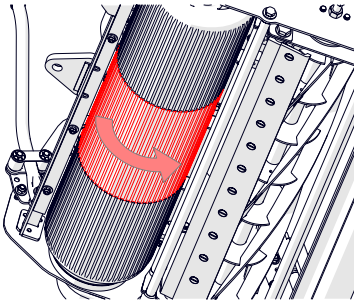

Fig.20A - Rotate central roller.

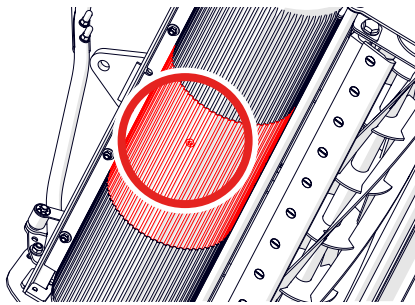

Fig.20B - Roller drain hole pointing downwards.

4.3. Adjustments and Settings

4.3.1. Handlebar Height Adjustment

Tools required:

- 2 x 17 mm spanner
1. Turn the machine *off*.
 2. Choosing either side of the machine, locate the three nuts at the bottom of handlebar and loosen [17 mm spanner] (Fig.21A & 21B). Secure the outer bolt head while doing so [17 mm spanner].
 3. Repeat with the other side.
 4. Adjust the handlebar to the desired height.
 5. When set, tighten the 6 x inner nuts.

Fig.21 - Handlebar adjustment

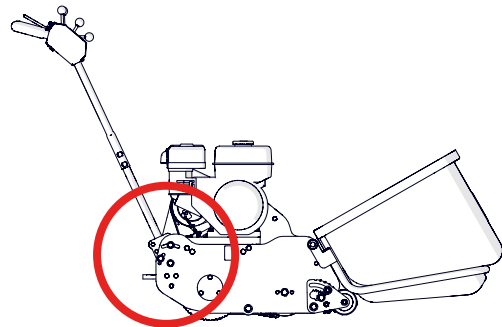

Fig.21A - Securing the bolt head

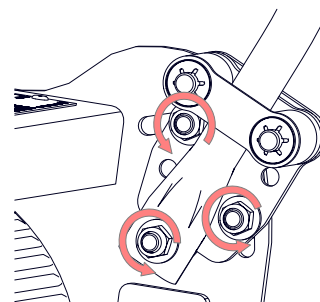

Fig.21B - Loosening the inner nut

4. Maintenance and Service

4.3.2. Shear Blade Adjustment



CAUTION - RISK OF INJURY

- **Always** turn the machine **off** before commencing this task.
- **Always** wear protective gloves to reduce risk of cuts and finger trapping.

Tools required:

- Scrap paper
- 2 x 19 mm spanner

1. Turn the machine **off** and disengage the cassette and drive levers.
2. Remove the grassbox and fold the carry frame up.
3. Tip the machine gently back so it rests on the rear roller and handlebar. Chock the rear roller to stop unintended rolling.
4. Choosing the left or right hand side of the cassette, test the cut by moving the cassette blade with a gloved hand and using a piece of paper between the cassette and shear blade (Fig.22A). If it does not cut the paper, or does not cut cleanly, then adjustment of the shear blade is required - see step 5. If it does cut cleanly, repeat test on the other side before proceeding to step 5 if required.
5. Located at each end of a cassette are two shear blade adjusters. On the side being adjusted, loosen the lock nut [19 mm spanner] (Fig.22B).
6. Adjust the gap with the adjustment nut [19 mm spanner] (Fig.22C). Only very small adjustments are required - start with $\frac{1}{8}$ of a turn and repeat the paper cut test. Repeat adjustment until the paper cuts cleanly.



NOTE - ADJUSTMENT DIRECTION

A sticker next to the adjuster informs of direction:

- ON = Decrease gap (i.e. cut 'on'),
- OFF = Increase gap (i.e. cut 'off').

7. Secure the lock nut.
8. Repeat step 6 on the opposite side.
9. Repeat the paper cut test on both sides. Adjust where necessary.
10. Lift the machine gently up to rest on its front and rear rollers. Unfold the grass carrier.
11. The machine is now ready for use.



NOTE - ORDER OF ADJUSTMENT

If planning on adjusting the height of cut at the same time, always adjust the shear blade first then adjust the height of cut. Doing the opposite way may result in a different height of cut.

Fig.22 - Shearblade adjustment

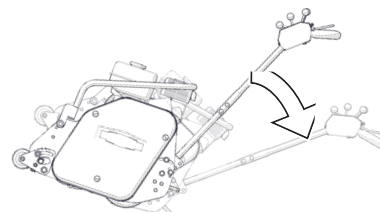

Fig.22A - Tip to rest of handlebars

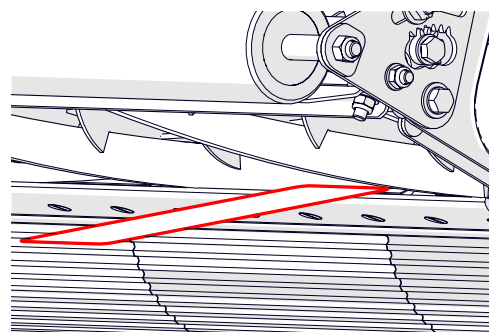

Fig.22B - Repeating adjustment for other side

4. Maintenance and Service

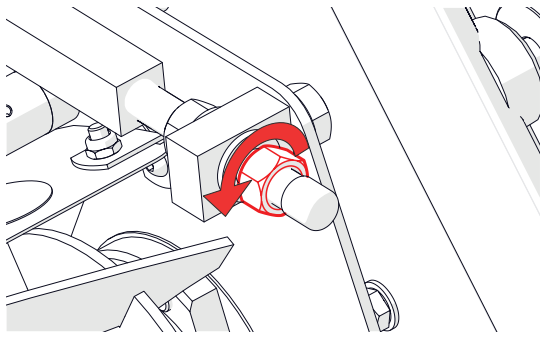

Fig.22C - Loosen the lock nut

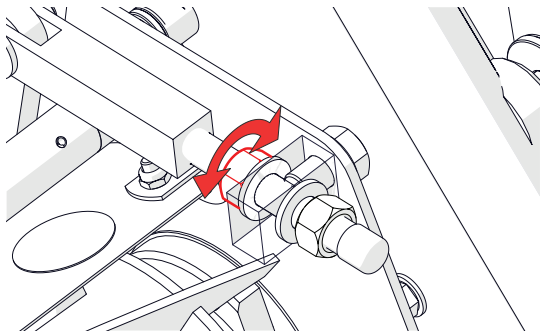

Fig.22D - Tighten/loosen the adjustment nut

4.3.3. Guide Peg Adjustment

The guide peg is located to quicken disengagement of the belt when the cassette tensioner pulley is in the *disengaged* position. It achieves this by providing a contact point for the belt and creating a small uplift, away from the top drive pulley. Without the peg in the correct position, the belt (and therefore cassette) will continue to run for a longer duration than necessary.

Tools required:

- Flat-headed screwdriver
- 13 mm spanner

1. Turn the machine **off**. Engage the parking brake and cassette lever.
2. Remove the belt guard [flat-headed screwdriver].
3. Loosen the guide peg hex screw [13 mm spanner].
4. Slide/rotate the guide plate until the guide peg is very close to the belt (but *not*

touching) and as high up as possible (Fig.23A & 23B). It must not make contact with any part of the cassette pulley.

5. Tighten the guide peg hex screw [13 mm spanner].

Fig.23 - Guide peg adjustment

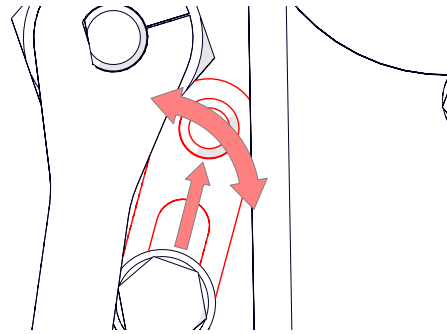

Fig.23A - Rotate and slide the guide to maximum

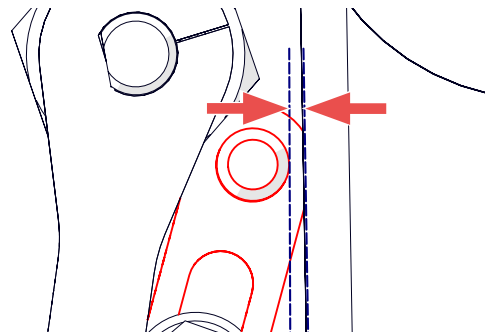

Fig.23B - Keep a very small gap between the peg and belt when pulley in the engaged

4. Maintenance and Service

4.4. Cleaning



CAUTION - WATER DAMAGE

Do *not* use a pressurised hose to clean your machine. Doing so may cause water ingress, damage and invalidate your warranty.



WARNING - SAFETY

Never place your hands inside the cassette area without firstly turning the machine *off*. We recommend to wear safety gloves and to use a long handled brush for cleaning.

Use a soft brush to remove as much grass and debris as possible. If further cleaning is required:

- **Chassis** - Remove the grass box and tilt the machine backwards so it rests on the handlebars. Using a low pressure hose, wash all of the grass from under the machine and around the cassette. Take extra care around the bearings, avoiding direct contact with the hose. Dry thoroughly after use.
- **Engine** - Allow to cool for at least 30mins before cleaning. Do *not* use a hose or pressurised hose to clean as this can cause damage. Use a damp cloth and brush.
- **Grass box** - Use a low pressure hose to rinse the inside of the box. Leave upside down to drip-dry before returning back to the machine.

4.5. Handling and Transport



WARNING - LIFTING

Do *not* lift the machine as it does *not* have designated lifting points. Lifting the machine may result in injury, damage to the machine, or both.

- Use a ramp to aid the machine onto a vehicle. For the technical specification of the machine, please refer to "**2.1. Technical Specifications**" p.11. The weight can also be found on the serial number plate.
- Anchor the machine to the floor/pallet using suitably rated tie-down straps. Anchor around the front and rear tie-bars (high-lighted red in Fig.24).
- Transport with fuel emptied - see note.
- Turn the machine *off* during transport (both from the engine and control components on the handlebar).



NOTE - SHIPPING THE ENGINE

Legislation for transporting and shipping a machine with an engine vary country to country. In most cases the fuel tank and carburettor must be completely emptied before transport. Additional requirements may include certification, declarations and packaging requirements. Always follow the requirements for your country and destination.

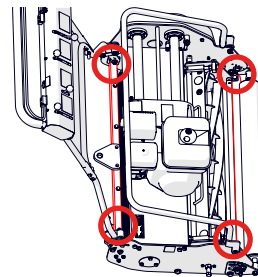

Fig.24 - Anchor points for transport.

4. Maintenance and Service

4.6. Storage

Follow the points below for correct storage of your machine. For the storage of petrol, refer to the regulations of your country:

- Store in a location away from direct sunlight, flames, heat sources and areas with high shock/vibrations.
- Store in a location maintaining a consistent temperature of 0°C to +30°C and avoiding high fluctuations.
- Store in a location that is dry, preferably with a relative humidity of 75% or less.
- If storing for >30 days, empty the fuel tank using a siphon pump. Over extended periods, petrol can degrade and absorb moisture, leading to engine and carburetor issues. See engine OEM 'Owner's Manual' for more information.
- Thoroughly clean and dry the machine prior to storage.
- Apply a small amount of grease to the cutting edge of the cylinder and shear blade. Use a small brush to achieve this.
- Store on a flat surface with the parking brake **on**. Chock the front and rear of the machine.
- Cover the machine to protect from damage and dust.



NOTE - INCORRECT STORAGE

Legislation for transporting and shipping a machine with an engine vary country to country. In most cases the fuel tank and carburettor must be completely emptied before transport. Additional requirements may include certification, declarations and packaging requirements. Always follow the requirements for your country and destination.

4.7. Disposal

4.7.1. Machine Disposal



NOTE - DISPOSAL NOTES

Check and comply with all environmental regulations and local disposal guidelines.

Dispose of the product in an environmentally friendly manner. The machine is predominately made up from metal waste - these can be suitably recycled at a local refuse collection site.



CAUTION - INJURY

Take care when removing components from the machine. If done incorrectly it may cause injury to yourself or damage to the surrounding environment. Wear suitable PPE and dismantle in an appropriate area.

1. Take the machine to a suitable area to allow for the removal of parts. Take into account access to the machine, tool availability, oil and other contaminants.
2. Wear suitable PPE. This must include safety glasses and gloves as a minimum.
3. Place oil absorbent pads under and around the machine.
4. Safely drain all fluids from the machine and engine using a siphon pump or similar, including oil and fuel. Use appropriate containers to collect these fluids and clearly label with their contents.
5. Clean the machine thoroughly.
6. Detach any removable parts, such as the handlebar, bodywork, rollers and cassette.
7. Separate recyclable parts like metal, plastic and electronic. Recycle at a recycling facility.
8. Dispose of non-recyclable components in accordance with local waste disposal regulations.

4. Maintenance and Service

9. Document the decommissioning process for record keeping.

4.7.2. Hazardous Materials

The engine contains petrol and oil which are classed as hazardous waste. Dispose of at a suitable recycling facility.

Other components to note include lubricating grease and roller bearing oil which may contaminate waste during recycling. The oil and grease should be removed prior to disposal with a suitable solvent or degreaser such as brake cleaner /denatured alcohol and wipes.

4.8. Troubleshooting & FAQ



WARNING - SAFETY

- You **must** turn the machine **off** before actioning any cause. Failure to do so may cause major injury.
- Always wear suitable PPE for the job at hand.

The most common troubleshooting issues are shown below. If your fault is not shown or you are still experiencing problems, please contact Howardson Group directly.

Issue	Possible Cause	Action
Engine won't start	[See OEM 'Owner's Manual']	[See OEM 'Owner's Manual']
Engine lacks power	[See OEM 'Owner's Manual']	[See OEM 'Owner's Manual']
Engine starts but stalls	<ol style="list-style-type: none"> 1. Choke left in the 'closed' position after warm-up. 2. Dirty carburettor. 3. Blocked fuel line or filter. 4. Low oil level triggering shutoff. 	<ol style="list-style-type: none"> 1. Move choke to the 'open' position. 2. Clean carburettor. 3. Inspect and clean fuel system. 4. Check oil level.
Engine runs rough or misfires	<ol style="list-style-type: none"> 1. Dirty or incorrect spark plug gap. 2. Contaminated fuel. 3. Air leak in intake system. 4. Clogged air filter. 5. Choke left in the 'closed' position after warm-up. 	<ol style="list-style-type: none"> 1. Clean or replace spark plug, check gap. 2. Drain and replace fuel. 3. Inspect intake gaskets and connections. 4. Clean or replace air filter. 5. Move choke to the 'open' position.
Grass does not cut.	<ol style="list-style-type: none"> 1. Cutting height is higher than grass length. 2. Gap between cylinder and shear blade is too much. 3. Cylinder and shear blades not sharp. 	<ol style="list-style-type: none"> 1. Adjust cutting height so it is below current grass height. 2. Adjust the shear blade - see "4.3.2. Shear Blade Adjustment" p.48. 3. See "4.2.3. Backlapping" p.43. If backlapping not sufficient, remove and re-sharpen using professional grinder/services.

4. Maintenance and Service

Issue	Possible Cause	Action
Cassette keeps spinning with the lever in the 'disengaged' position.	<ol style="list-style-type: none"> 1. Clutch is stuck or set too taut and cannot disengage with the cassette belt. 2. Guards surrounding the belt are set too close and providing a form of 'clutch'. 3. Guide peg is not set correctly and not providing the extra support for disengagement. 	<ol style="list-style-type: none"> 1. Re-tension cassette belt. See <i>"4.2.1. Cassette and Drive Belt Replacement/Tensioning" p.39.</i> 2. In the disengaged state, the belt should be static despite the upper pulley still spinning. Open the belt guard and readjust the guards away from the belt so they do not make contact. See <i>"4.2.1. Cassette and Drive Belt Replacement/Tensioning" p.39.</i> 3. In the disengaged state, the belt should be making light contact with the guide peg. See <i>"4.3.3. Guide Peg Adjustment" p.49</i>
Cassette does not spin with the lever in the 'engaged' position.	<ol style="list-style-type: none"> 1. Clutch is set too loose and cannot engage with drive belt. 2. Guide peg making contact with the tensioner pulley stopping it fully engage. 3. Faulty OPC. 	<ol style="list-style-type: none"> 1. Re-tension cassette belt. See <i>"4.2.1. Cassette and Drive Belt Replacement/Tensioning" p.39.</i> 2. Engage the cassette lever and check the tensioner pulley does not contact the guide peg. If it does, readjust the guide peg accordingly. 3. Inspect the micro-switch of OPC, replace if necessary.
OPC will not disengage when released	<ol style="list-style-type: none"> 1. Check the OPC operates freely and no damage to pivot block. 2. Parking brake microswitch faulty. 	<ol style="list-style-type: none"> 1. Service/replace OPC if faulty. 2. Service/replace OPC if faulty.

4.9. Warranty Policy

For full warranty terms and conditions, please contact your Dealer or refer to the warranty policy supplied separately.

Appendix

Appendix A. Optional Items and Attachments

A1. Weile (Grooved) Roller

This option replaces the standard wheel and brush configuration with a weile (grooved) roller. A weile roller has less surface area, allowing for the leaf blades to stand more upright in the grooves prior to being cut. This generally achieves a more consistent height and quality of cut compared to a smooth roller. It achieves less marking than the wheel option.

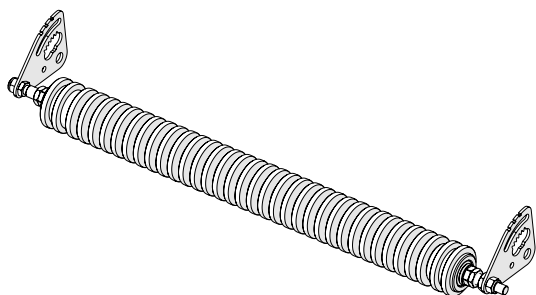

Fig.25 - Weile Roller

However, a smooth roller distributes the machine weight more evenly provides and is therefore less aggressive on the turf. Use a smooth roller on well maintained, level turf, or if your turf is stressed, recently aerated, or wet.

To remove the roller:

1. Remove the three fixings from the roller quadrant, as illustrated in Fig.26A [19 mm spanner, 17 mm spanner].
2. Loosen (do not remove) the M12 bolt securing the tie-bar [19 mm spanner] (Fig.26B).
3. The roller quadrant will now be able to move slightly to make space to remove the front roller (Fig.26C).
4. Replace the roller as desired and move the roller quadrant back into position.
5. Tighten the M12 bolt securing the tie-bar.
6. Reattach and tighten the three fixings from the roller quadrant

Fig.26 - Front roller removal

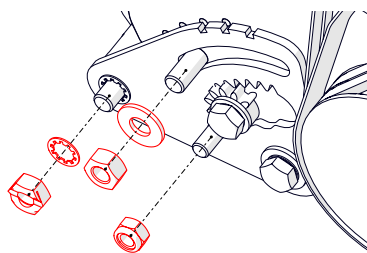

Fig.26A - Remove the three fixings as illustrated.

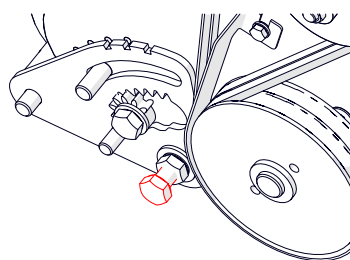

Fig.26B - Loosen the tie-bar bolt.

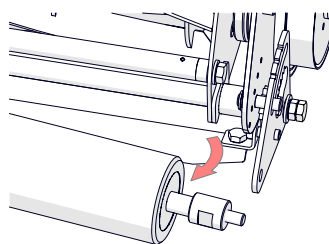

Fig.26C - Remove the roller.

Appendix

A2. Suspension trailer seat

Both the standard and self-steer trailer seats are designed to reduce operator fatigue during extended periods of use. They also add an additional level of striping along with the rear roller of the machine. Both seats have built-in suspension and adjustments for greater comfort.

They are supplied with a tow ball and bracket that is mounted to the rear tie bar of the machine.

The self-steer trailer seat has an additional pivot underneath the seat and a cross brace from the machine rear tie bar to the trailer seat rear roller. This allows for greater manoeuvrability, with the trailer seat following the turns of the machine more closely.

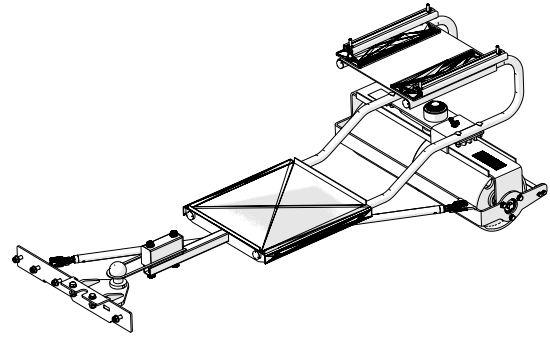

Fig.27 - Suspension trailer seat (frame only).

Appendix B. Service Kit

The service kits below are available to be purchased to aid in the servicing of the machine:

Machine	Service area of machine	Kit number	Item description	Item part number	Qty
G-Series	(SK04) - Handles	SK04002	Throttle Cable	SP12002	1
			Grommet PV270A	260138	1
			Cutter Drive Clutch Cable	229378	1
			Cable Return Spring	229422	1
			Roller Drive Clutch Cable	229596	1
			Cable Return Spring (not cylinder)	229421	1
			Brake Cable	229597	1
G860 only	(SK06) - Cutter	SK06002	34" Lipped Shear Blade	229229	1
			Blade Screw (12 needed)	185378	12
			Oil Seal	229701	2
			Grease Nipple 1/4" UNF	J20064	2
			Bearing 2205 2RS	228029	2
G760 only	(SK06) - Cutter	SK06003	30" Lipped Shear Blade	067171	1
			Blade Screw (10 needed)	185378	12
			Oil Seal	229701	2
			Grease Nipple 1/4" UNF	J20064	2
			Bearing	228029	2

Appendix

Machine	Service area of machine	Kit number	Item description	Item part number	Qty
G-Series	(SK02) - Rear Roller	SK02009	Roller Bearing 6205-2RS	062662	2
			Bearing 6204-2RS 3	J20052	4
			Rear Roller Drive Belt - 4pk 698	228012	1
			Pin Spirol M5 X 45	228053	1
			Tensioner Pulley	229038	1
			Hex Set Screw 3/8" UNF X 2 1/2"	SP01068	1
			Nut 3/8" UNF Nyloc (T)	SP02018	1
			Grease Nipple 1/4" UNF	J20064	1
			Grub Screw M8 X 8	J20467	1
			Grub Screw 3/8" BSPT	171702	1
			Gear Oil Ep90 (860 Qty)	OIL	0.7l
	(SK06) - Cutter	SK06010	Cylinder Drive Belt - V Z-997	228030	2
			Drive Gasket	229335	1
			Roller Bearing 6205-2RS	062662	2
			Coupling Element	228103	1
			Tensioner Pulley	229038	2
			Hex Set Screw 3/8" UNF X 1 1/2"	SP01071	1
			Nut 3/8" UNF Lock (Thin)	SP02033	1
			CSK Cap Head M8 X 16	SP01077	4
			Grub Screw M8 X 8	J20467	1
			Bearing 6204-2rs 3	J20052	2
	(SK05) - Drive / Power	SK05009*	Cylinder Drive Belt - V Z-997	228030	2
			Rear Roller Drive Belt - 4pk 698	228012	1
			Transmission Drive Belt - V X10-665 LP	228007	1

*Belt kit - not required with cutter or drive kit

Page intentionally left blank.

Page intentionally left blank.

Page intentionally left blank.

DENNIS



Email
sales@howardsongroup.com

UK & International
Tel: +44 (0) 1332 824777

Head Office
Ashbourne Road, Kirk Langley,
Derby DE6 4NJ, UK

Due to a policy of continual development Howardson Group Ltd reserves the right to change specification without prior notification.
All goods sold subject to the company's terms and conditions of sale, copies available on request.

E&EO