

Operator Manual

Petrol Dedicated Mower

G26D / G30D / G34D



DENNIS

Original Instructions in English (UK). Part number: SP20038.

Models covered: G26D (D147) / G30D (D146) / G34D (D145).

Rev.	Date	Description of Changes	Author
7.0	28/ APR/ 2026	Complete redesign of manual.	C.B

For a digital copy of this manual, parts catalogue and other information regarding this product, please scan:



For a digital copy of the Honda engine documentation, please scan:



Serial numbers:

Chassis
Engine

Head Office

Howardson Works,
Ashbourne Road,
Kirk Langley,
Derbyshire,
DE6 4NJ,
UK
Tel: +44 (0) 1332 824 777
howardsongroup.com

Copyright © 2004-2026 by Howardson Group Ltd. All Rights Reserved.

This document and all content within it, is protected by copyright and is the property of Howardson Group Ltd. You may not distribute, modify, transmit, copy or use the content of this document in any way, electronic or otherwise, whether in whole or in part, for commercial purposes or for personal gain. Any storage, reproduction or redistribution of the content by any means is prohibited without prior written consent from Howardson Group Ltd. You may store extracts from this document for your personal use only.

While every effort has been made to ensure the accuracy and completeness of the information contained in this manual, we assume no responsibility or liability for errors or omissions. The information provided is on an "as is" basis without any warranties of any kind, either expressed or implied. We reserve the right to make changes to the product and its documentation at any time without prior notice. This includes, but is not limited to, modifications to the design, specifications, and functionality of the product. The latest version of the manual will be available on our website or through our customer service department. Some imagery may not reflect the actual product you have.

Table of Contents

1. Introduction	5
1.1. Operator Manual Overview	5
1.2. Machine Description	5
2. Safety Information	6
2.1. Safety Statements	6
2.2. Warning Symbols	6
2.3. Safety Instructions	6
2.3.1. General Safety Instructions	7
2.3.2. Engine and Fuel Safety Instructions	7
2.3.3. Mechanical Safety Instructions	8
2.3.4. Noise and Vibration Safety Instructions	9
2.3.5. Personal Protective Equipment (PPE)	9
2.3.6. Intended Use and Residual Risks	9
2.3.7. Machine Decals	10
3. Assembly and Installation	11
3.1. Unpacking and Inspection	11
3.2. Assembly Instructions	11
3.3. Installation Requirements	12
3.4. Commissioning	12
3.5. Calibration	12
4. Machine Overview	13
4.1. Technical Specifications	13
4.1.1. Dimensions	13
4.1.2. Specification Table	14
4.1.3. Noise and Vibration	15
4.2. Machine Components	16
4.3. Control Components	18
4.4. Engine Components	20
5. Operation and Emergency Procedures	21
5.1. Pre-Start and Safety Checks	21
5.2. Cutting Preparation	21
5.2.1. Adjust Height of Cut	21
5.2.2. Handlebar Height Adjustment	24
5.2.3. Shear Blade Adjustment	24
5.3. Engine	26
5.3.1. Safety Information	26
5.3.2. Refuelling	26
5.3.3. Installation and Removal	26
5.3.4. Engine Specifications	26
5.3.5. Replacement and Disposal	26
5.4. Starting the Engine	27
5.5. Stopping the Engine	29
5.6. Drive	29
5.6.1. Moving and Transport (no cut)	29
5.6.2. Operating on Slopes	30
5.7. Cutting	31
5.7.1. Moving and Cutting	31
5.7.2. Cutting Technique	32
5.8. Operating Environment	33
5.9. Emergency Procedures	34
5.9.1. In the Event of a Breakdown	34
5.9.2. Hazardous Substances and Fire	34
6. Maintenance and Servicing	36
6.1. Maintenance Schedule	36
6.2. Servicing Instructions	39
6.2.1. Cylinder and Drive Belt Replacement/ Tensioning	39
6.2.2. Transmission Belt Replacement/Tensioning	42
6.2.3. Removing a Cylinder	44
6.2.4. Backlapping	46
6.2.5. Grinding Cutting Blades	47
6.2.6. Checking/Tensioning Parking Brake	48
6.2.7. Changing Rear Roller Oil	49
6.2.8. Lubrication	50
6.2.9. Guide Peg Adjustment	51
6.3. Cleaning	51
6.4. Handling and Transport	52

Table of Contents

6.5. Storage52
6.6. Disposal53
6.6.1. Machine Disposal53
6.6.2. Hazardous Materials53
6.7. Troubleshooting & FAQ53
6.8. Warranty Policy53

Appendix **54**

Appendix A. Optional Items and Attachments54
A1. Weile (Grooved) Roller54
A2. Suspension trailer seat55
Appendix B. Service Kit56
Appendix C. FAQ and Troubleshooting57

List of Key Figures

Fig.1. Viewpoints	5
Fig.2. Assembly Instructions	11
Fig.3. Machine components overview.	16
Fig.4. Control components overview.	18
Fig.5. Engine components overview.	20
Fig.6. Adjusting Height of Cut	22
Fig.7. Handlebar adjustment	24
Fig.8. Shearblade adjustment	25
Fig.9. Power on procedure	27
Fig.10. Power off procedure	29
Fig.11. Driving procedure	30
Fig.12. Cutting procedure	31
Fig.13. Drive belt replacement / tensioning	40
Fig.14. Transmission belt adjustment	42
Fig.15. Removing and Inserting a Cylinder	44
Fig.16. Backlapping	46
Fig.17. Recommended cylinder grind angle	47
Fig.18. Recommended shear blade grind angle	47
Fig.19. Illustration of two different shear blade angles and their grass contact point	48
Fig.20. Rear roller oil	49
Fig.21. Guide peg adjustment	51
Fig.22. Anchor points for transport.	52
Fig.23. Weile Roller	54
Fig.24. Front roller removal	54
Fig.25. Trailer Seat Attachment	55

1. Introduction

1.1. Operator Manual Overview

This operator manual contains important information regarding the safe, proper and efficient operation of the G26D/G30D/G34D, referred to as 'machine' in this manual. This operator manual must always be available and read by every User of the machine. 'User' is defined as an authorised person tasked with working on or with the machine, typically operators, groundskeepers and maintenance personnel.

Adherence to this operator manual will help to avoid and minimise risk to you as the User and to the machine. It will also lead to a greater quality of cut, lower repair costs and reduce downtimes. Prior to use, every User must ensure they have:

- Fully read and understood these instructions,
- Understood the machine controls,
- Understood the dangers and hazards involved, and methods to mitigate risk.

Reference will be made to the use, safety and maintenance of the petrol engine. However this is supplementary information only and you must also read the supplied OEM manual for the engine.

In the case of any difficulty or if further information is required, call Dennis or your Dealer. In the interests of speed and accuracy of information, please quote the serial number of the machine when making enquiries.

Location descriptions (e.g. left/right hand) throughout this manual are observed from the operators view whilst in normal drive position, as per Fig.1.

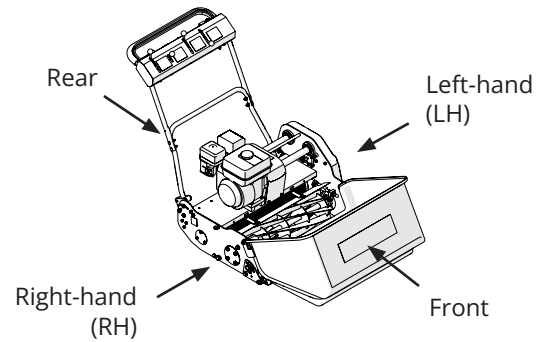

Fig.1. Viewpoints

1.2. Machine Description

The G26D, G30D and G34D are professional petrol grass mowers, using a 26" (660 mm), 30" (762 mm) or 34" (863 mm) cylinder respectively. This is a dedicated (i.e. non-removable cylinder) machine using a large cylinder for maximum performance.

All models are powered by an air cooled, single cylinder, four stroke petrol engine, the specification of which can be found in the supplied OEM manual, or selected specifications in this manual.





The rear roller and cylinder are controlled independently, operated from the controls located on the handlebar.

The design of the machine incorporates a system for quick adjustment of the height of cut and a sectional assembly system for easy service and maintenance of the main components. A mechanical parking brake is fitted which, when applied, prevents drive being engaged.

2. Safety Information

2.1. Safety Statements

Throughout this manual, potential safety risks are identified with a word and coloured coded box. They denote the following:

 DANGER	 WARNING
Indicates an imminently hazardous situation which, if not avoided, will result in death or serious injury.	Indicates a potentially hazardous situation which, if not avoided, could result in death or serious injury.
 CAUTION	 NOTE
Indicates a potentially hazardous situation which, if not avoided, may result in minor or moderate injury.	Indicates information considered important but not hazard related.

2.2. Warning Symbols

The following warning symbols are used throughout this Operator Manual and across the machine. Familiarise yourself with them prior to operating the machine. They are located near areas of potential danger or convey further information on machine use.

Warning Signs



General warning sign



Warning; Sharp element

Prohibition Signs



General prohibition sign

Mandatory Signs



General mandatory action sign



Refer to instruction manual/booklet



Wear ear protection



Wear eye protection



Wear protective gloves



Wear safety footwear

Other Signs



Take note



Heavy weight

2.3. Safety Instructions



DANGER - SAFETY INSTRUCTIONS

This machine can cause serious injury if it is not used correctly. Before use, carefully read all following safety instructions and the potential hazards that could occur. It is essential they are adhered to.

Failure to follow the safety information and correct operating procedures may result in serious injury or death.

2. Safety Information

2.3.1. General Safety Instructions



WARNING - GENERAL SAFETY INSTRUCTIONS

This machine contains mechanical and combustion engine related hazards. **Always** read this operator manual carefully, taking care to understand all safety instructions.

Training and Access

- Read and understand all instructions and machine hazards before use.
- Only trained and authorised personnel may operate the machine.
- The machine owner must ensure the manual is accessible to all users at all times.

Area Safety and Exclusion

- Never allow children to operate the machine, enter the work area or access the machine while in storage.
- Maintain a safe distance from pedestrians and remain alert to your surroundings.
- Prevent any unauthorised person from interacting with the machine under any circumstances.

Safe Operation

- Always keep both hands on the handlebar.
- Never exceed a standard walking pace.
- Operate only within the specific environmental conditions defined in "**5.8. Operating Environment**" p.33.

Fitness for Work

Do **not** operate the machine if your judgment or physical ability is impaired by:

- Illness or fatigue.
- Reduced physical capacity.
- The influence of drugs or alcohol.

2.3.2. Engine and Fuel Safety Instructions



WARNING - ENGINE AND FUEL SAFETY

This machine uses petrol and contains hot engine components. Incorrect handling poses a risk of fire, explosion, carbon monoxide exposure or serious burns. Always follow the guidance shown.

Fuel Handling

- Always use regular unleaded petrol only (pump octane rating 86 or higher). Using the wrong fuel will damage the engine.
- Always refuel outdoors with the engine switched off and cool. Never add fuel while it is running.
- Never smoke or use naked flames near petrol or the fuel system.
- Always wear correct PPE when handling fuel.
- Do not overfill the fuel tank.
- Clean up spilled fuel immediately. Ensure the engine is started a safe distance away from the spill after cleaning up.
- Never start or operate the machine if you suspect a leak.
- **Flammable risk** - Always store the petrol in a suitable container, away from direct sunlight, high temperatures and areas with risk of sparks.

Engine Operation

- This manual includes general guidance for the operation and maintenance of the engine. Always read the OEM engine 'Owner's Manual' provided for specific instructions and safety information not covered in this manual.

Note the following:

- The OEM engine manual takes precedence for all engine technical specifications.
- The recommended service intervals covered in this Operator Manual may

2. Safety Information

differ to the OEM. In cases of discrepancy, follow the more frequent service interval.

- Only operate the engine in open, well-ventilated areas. Exhaust gases contain carbon monoxide and other toxic gases that can be fatal if accumulated.
- Always disengage the drive and cylinder levers before starting the engine. Start the engine carefully following the instructions.
- Keep the exhaust, fuel tank and surrounding engine parts free from grass, debris, and oil build-up.
- Do not tilt the mower excessively while the engine is running.
- Never change engine governor settings or overspeed the engine.
- Never carry out adjustments whilst the machine is running.

Hot Surfaces

- Engine components and the exhaust system become extremely hot during operation and remain hot long after use. Never touch engine parts until the machine has fully cooled.
- Allow the engine to cool completely before storing or carrying out any maintenance.
- Keep clothing, hands, feet, and combustible materials clear of hot surfaces at all times.
- Never place anything in the engine due to fire risk.

Maintenance and Inspection

- Always keep the engine maintained with the schedule and procedures found in "**6. Maintenance and Servicing**" p.36 and in the maintenance section of the OEM engine 'Owner's Manual'.
- Allow the engine to cool completely before refuelling, storing, transporting, servicing or performing maintenance.
- Always switch off the engine and disconnect the spark-plug lead before cleaning, inspect-

ing or servicing.

- Inspect the fuel tank, fuel lines, cap and fittings regularly. Do not operate the machine if any part of the fuel system is damaged or leaking.
- Use only genuine replacement parts to maintain correct safety and performance.

Prohibitions

- Never open, modify or attempt to repair internal engine or fuel components. Strictly for qualified personnel only. Incorrect repair can cause fire, explosion, or severe injury.
- Never puncture, crush, incinerate, immerse in water or tamper the engine in any way - risk of fire or explosion.

2.3.3. Mechanical Safety Instructions



WARNING - MECHANICAL SAFETY INSTRUCTIONS

This machine contains sharp, fast-moving parts. Improper use can result in serious injury. Always keep all body parts away from rotating components, which may continue to move after power-off. Never operate without protective guards or bypass safety devices.

Vigilance

- Components such as blades, brushes and rollers can continue to rotate for a short period after the machine is switched off; maintain full attention until all motion has completely ceased.
- If any component is damaged, loose or excessively worn, **stop using the machine immediately.**

Maintenance and Inspection

- Carry out maintenance checks as shown in "**6.1. Maintenance Schedule**" p.36 to ensure safe and reliable operation.
- All servicing and repair must be carried out

2. Safety Information

by a suitably qualified person using genuine parts.

2.3.4. Noise and Vibration Safety Instructions



WARNING - NOISE AND VIBRATION SAFETY INSTRUCTIONS

This machine generates noise and low levels of mechanical vibration during normal use. Always use hearing protection to allow safe, extended operation and prevent long-term health risks associated with noise exposure.

Consult local regulations for vibration exposure limits. Do not exceed the maximum allowable duration for machine operation.

- If abnormal noise or vibration is detected, stop using the machine immediately and inspect it for damage or wear.
- Ensure all maintenance is carried out as specified to keep noise and vibration levels within their intended limits.

2.3.5. Personal Protective Equipment (PPE)

During use you must adhere to local rules and regulations regarding Personal Protective Equipment (PPE). In addition to this we recommend to wear:



- **Footwear;** heavy duty, slip resistant boots to protect against injury.



- **Eye protection;** to protect from flying debris.



- **Hearing protection;** must be worn at all times when the machine is activated.



- **Clothing;** suitable for the environment you are operating in (hot, cold, wet etc)



- **Hand protection;** to avoid cuts and blisters.



- **Respiratory protection;** for when there are occurrences of high dust and pollen.

2.3.6. Intended Use and Residual Risks



WARNING - INTENDED USE AND RISK

This machine is designed solely for cutting fine grass surfaces. Never use the machine for anything else other than this purpose. Personal injury and damage to the machine can result in using the machine for alternative uses.

Limitations

- Do not use the machine to cut grass above the maximum specified cutting height, or to cut thick, coarse vegetation expected for the use of different equipment (e.g. brushcutters or strimmers).

Prohibited Operations

- Do not ride on the machine, tow it, or use it to carry loads or transport goods.
- Do not use the machine as a general-purpose tool for any task other than fine grass cutting.
- Do not modify the machine or fit non-approved attachments.

Surfaces

- Do not operate the machine on surfaces other than grass (e.g. gravel, bare soil, hard surfaces). Operating on other terrain may cause damage or create hazards (such as flying debris).

2. Safety Information

2.3.7. Machine Decals

Your machine decals must be replaced when they become worn or damaged. Contact Howardson Group Service department with the part number listed below:



B32902_REV2 -
(200x50mm)
J20362_REV2 -
(120x30mm)



229600



229601



229602



229603



229599



229375



229376



B32903_REV0



SP18037 (95dB)

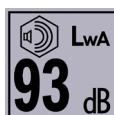

SP18068 (93dB)

3. Assembly and Installation

3.1. Unpacking and Inspection

The machine will arrive on a wooden pallet base, with either a cardboard or wooden outer frame. Carefully remove this outer packaging. You alternatively may have the machine delivered direct from our factory or your Dealer.

Visually inspect the machine for any signs of damage which may have occurred during transport. Contact Howardson Group or your Dealer as soon as possible should there be damage.

Included with the machine is this operator manual, a warranty registration document and machine parts catalogue.

To remove the machine from the pallet:

1. Remove all tie-down straps.
2. Wherever possible, use a suitably rated ramp to roll the machine off backwards to the ground. Refer to section "5. Operation and Emergency Procedures" p.21 for the relevant procedures. Gently toggle the park brake on/off to aid going down the ramp.



CAUTION - MACHINE WEIGHT

The machine is very heavy. Machine weight can be found on the serial plate or section "4.1.2. Specification Table" p.14. Take care when removing from the wooden pallet - we recommend two people to help with this. Follow all manual handling techniques for your business and region.

3. If a ramp is not available, disengage the parking brake and, while following correct manual handling techniques, **gently** lower the rear roller to the floor. Continue to roll backwards, keeping pressure on the handlebar so the front wheels remain in the air. Once clear of the pallet, lower the front to the floor **gently**.

Dispose of all packaging according to local laws - recycle where possible.

3.2. Assembly Instructions

Minimal assembly is required to get your machine into a ready state:

1. **Attach the grass box;** lower the grass box frame towards the front of the machine (Fig.2A). Lift the grass box onto this frame (Fig.2B), removing any plastic wrapping that may be left.
2. **Set handlebar height;** the handlebar may need readjusting to be optimum for your height. See section "5.2.2. Handlebar Height Adjustment" p.24 for further information.
3. **Fill the fuel tank** with unleaded petrol (see OEM manual supplied for more information).

Fig.2. Assembly Instructions

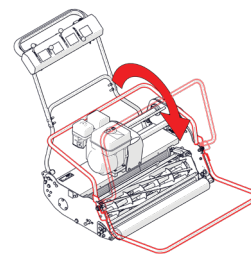

Fig.2A - Lower grass box frame.

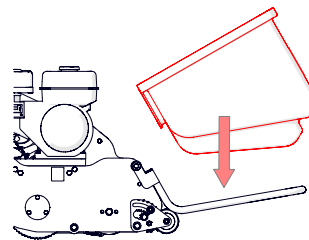

Fig.2B - Grass box fitment.

3. Assembly and Installation

3.3. Installation Requirements

Adjustments will be required to make adequate space for the storage and routine maintenance of the machine:

- See section "*4.1.1. Dimensions*" p.13 for minimum space requirements.
- See section "*6.5. Storage*" p.52 for correct storage requirements.

3.4. Commissioning

Your Dealer or a Howardson Group representative will be present to commission and set-up your machine. They will walk through the process of basic controls and getting started with your machine.

3.5. Calibration

No calibration procedures are required.

4. Machine Overview

4.1. Technical Specifications

4.1.1. Dimensions

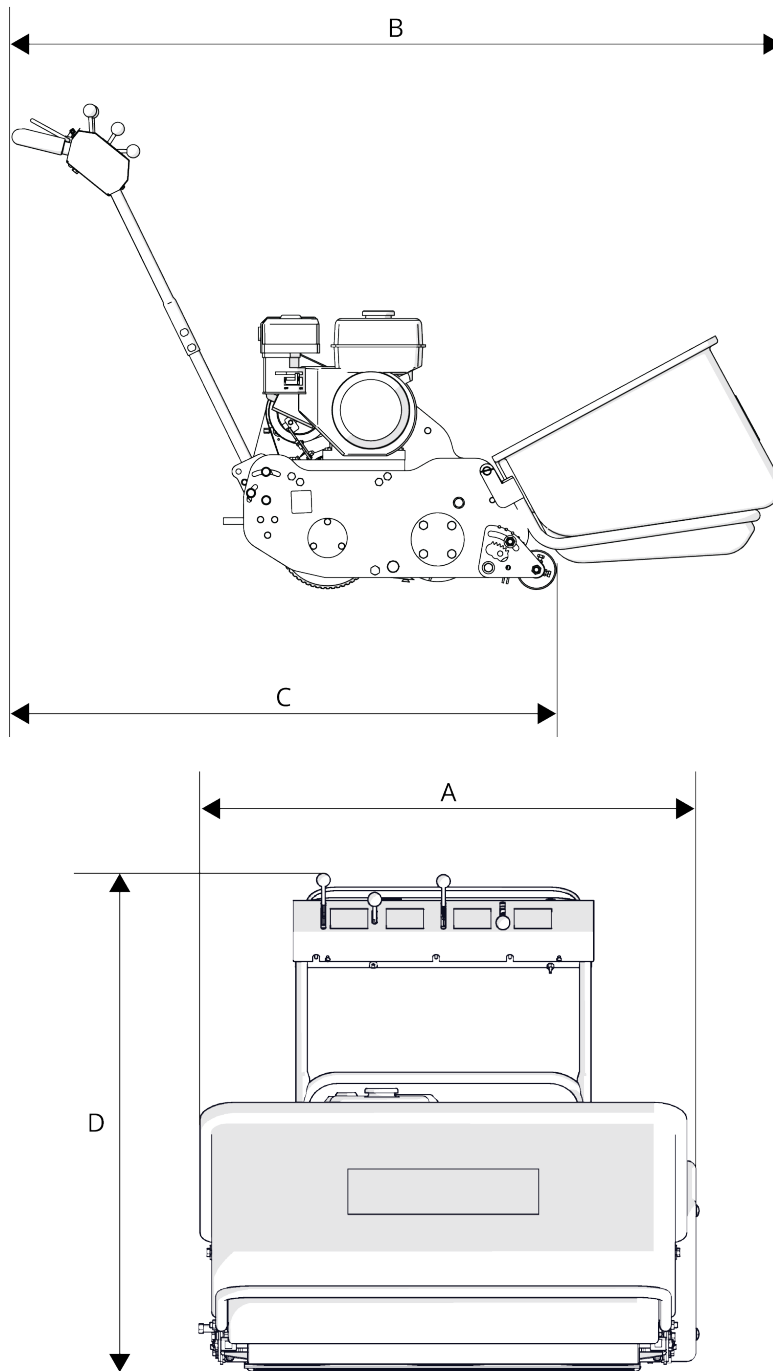

View	Model		
	G26D	G30D	G34D
A	884 mm	984 mm	1084 mm
B	1635 mm		
C	1121 mm		
D	1119 mm		

4. Machine Overview

4.1.2. Specification Table

System		Model			
		G26D	G30D	G34D	
Weight	Machine	163 kg	178 kg	200 kg	
Drive	Engine ¹	Type	Petrol Engine		
		Model	Honda GX160		
		Net Power	3.6 kW / 3,600 rpm		
		Fuel Tank Capacity	3.1 L		
		Engine Oil Capacity	0.6 L		
		Engine Oil Type	Genuine Honda, SAE 10W-30		
		Dry Weight	15.1 kg		
		Spark Plug Type	BPR6ES (NGK) or W20EPR-U (DENSO)		
		Spark Plug Gap	0.7–0.8 mm		
	Rear Roller System	'V' Belt			
	Cylinder Drive System	Multi 'V' Belt			
	Rear Roller Diameter	228 mm			
	Front Roller Diameter	89 mm			
	Speed (maximum)	Forwards	3.21 km/h		
Cutting	Blade unit	Dedicated cylinder			
	Cutting Width	26" [660 mm]	30" [762 mm]	34" [863 mm]	
	Number of blades	8 or 11			
	Height of cut	14–47 mm			
	Clips per metre	8 blade	117		
		11 blade	161		
	Grassbox volume	160 L	180 L	200 L	

4. Machine Overview

System		Model		
		G26D	G30D	G34D
Environmental	Operating temperature range	-20°C to +40°C (+10°C to +30°C optimal)		
	Storage temperature range	-20°C to +35°C For additional information, see section "6.5. Storage" <i>p.52.</i>		

¹For technical specifications of the engine, please refer to the 'Owner's Manual' supplied.

4.1.3. Noise and Vibration



WARNING - NOISE AND VIBRATION

This machine generates noise and low levels of mechanical vibration during normal use. Always use hearing protection to allow safe, extended operation and prevent long-term health risks associated with noise exposure.

System		Model		
		G26D	G30D	G34D
Noise	Measured Sound Power Level	90 dB(A)	92 dB(A)	92 dB(A)
	Guaranteed Sound Power Level	93 dB(A)	95 dB(A)	95 dB(A)
Vibration	Total value to which the hand-arm system is subjected	2.6 m/s ²	2.6 m/s ²	2.6 m/s ²

4. Machine Overview

4.2. Machine Components

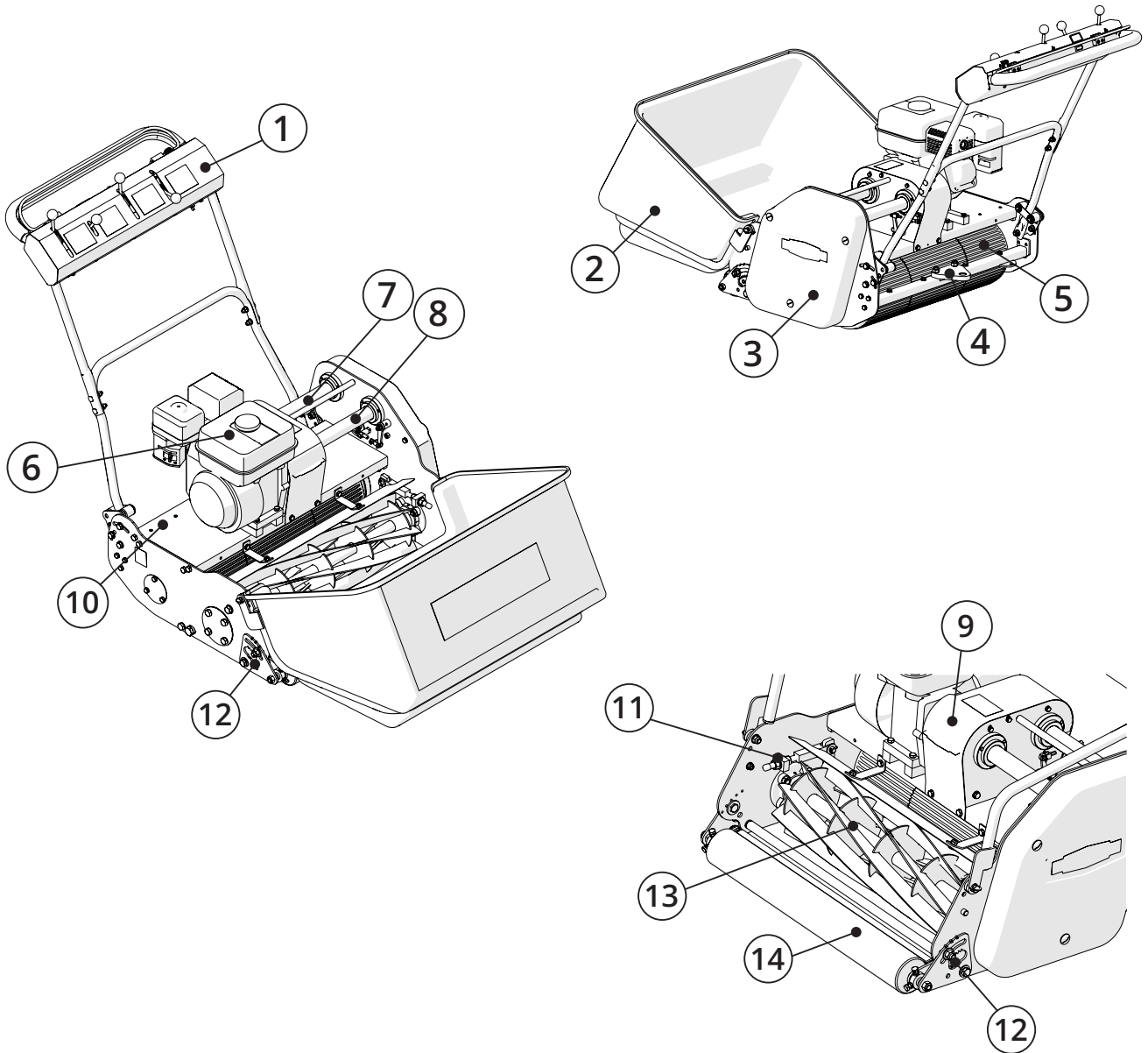

Fig.3. Machine components overview.

- | | |
|-----------------------------------|--------------------------------|
| 1. Control Components | 8. Driveshaft guard - Cylinder |
| 2. Grass Box | 9. Transmission guard |
| 3. Belt Guard | 10. Serial Plate |
| 4. Towbar Bracket | 11. Shear Blade Adjuster |
| 5. Rear Roller | 12. Cut Height Adjuster |
| 6. Engine | 13. Cylinder |
| 7. Driveshaft guard - Rear Roller | 14. Front roller |

4. Machine Overview

1. Control Components

See "4.3. Control Components" p.18.

2. Grass Box

The grass box collects the clippings from the cylinder. Maximum volume: G26 = 160 L, G30 = 180 L, G34 = 200 L.

3. Belt Guard

Behind the belt guard contains two belt and pulley assemblies; one set for the rear roller and one set for the cylinder. This guard protects the operator and machine from injury and damage. It must be kept on and secured at all times.

4. Towbar Bracket

For use with the optional trailer seat attachment. See "A2. Suspension trailer seat" on page 55

5. Rear Roller

The rear roller maintains stability along with the front roller, but also creates a striping effect behind the machine. It is split into three segments, with the two outer segments operated by differential to aid in manoeuvrability.

6. Engine

Refer to supplied OEM manual and "4.4. Engine Components" p.20 for further information.

7 / 8. Driveshaft Guards

Within each of these guards are drive shafts, transmitting power from the engine to the rear roller and cylinder pulley/belts, respectively. They must be kept on and secured at all times.

9. Transmission Guard

Behind the transmission guard is a single belt and pulley assembly to split power from the engine to both cylinder and rear roller drive shafts. Here is also the parking brake system composing of the brake pads and caliper. The guard must be kept on and secured at all times.

9. Serial Plate

The serial number can be found on the right-hand side of the machine, near the handlebar adjuster. Please make a note of the serial number of your machine and engine in the table found on the inside cover of this manual. Always quote these in any communication with Dennis.

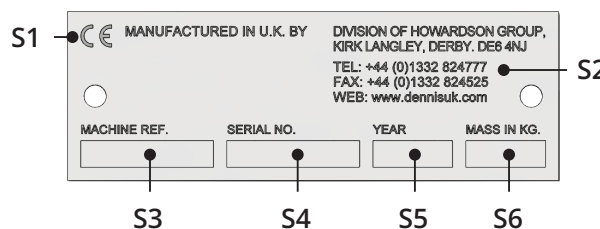

Fig. 3A - Serial plate components overview.

- S1. CE marking
- S2. Business/manufacture address and contact details
- S3. Machine code designation
- S4. Serial number
- S5. Year of build
- S6. Mass of machine (kg)

11. Shear Blade Adjuster

Over time the quality of cut will decrease due to blade wear. Adjustment of the shear blade carrier is required to maintain the cut "5.2.3. Shear Blade Adjustment" p.24.

12. Cut Height Adjuster

Located either side of the machine, cut height is adjusted here - see "5.2.1. Adjust Height of Cut" p.21.

13. Cylinder

The cylinder is the cutting unit of the machine. It is a dedicated (i.e. non-removable) cylinder in operational use, but can be removed for re-grinding and replacement.

Replace a worn or damaged cylinder with genuine Dennis replacement.

4. Machine Overview



DANGER - CYLINDER BLADES

Worn or damaged blades are dangerous. Incorrect use or maintenance can cause serious injury or death. Inspect before and after every use, as per "6.1. Maintenance Schedule" p.36.

Always inspect the blades/discs with the machine **off**.

14. Front Roller

The front roller maintains stability and guides the machine. As standard, a Smooth roller is supplied but a Weile roller is available as an optional extra.

4.3. Control Components

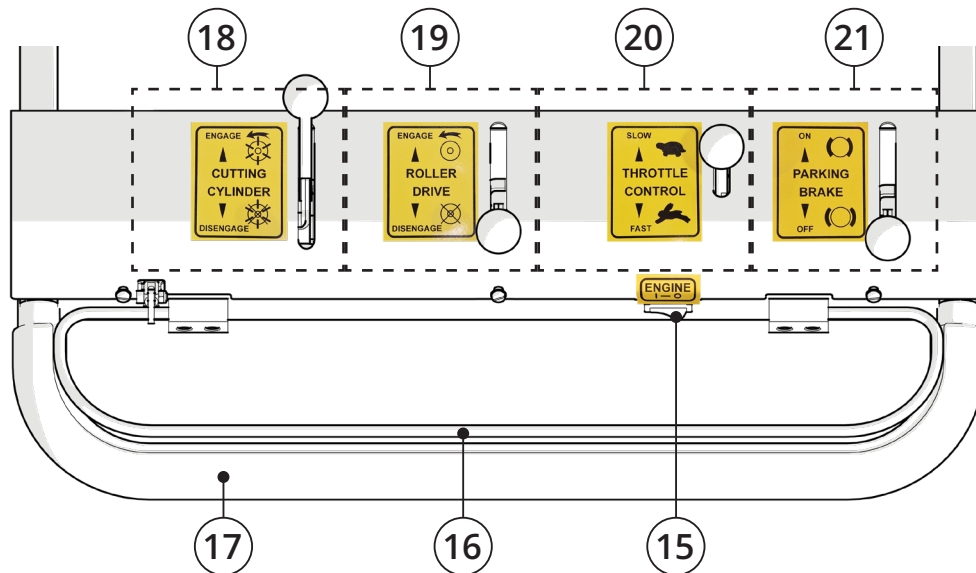

Fig.4. Control components overview.

- 15. Start Switch
- 16. Operator Presence Control (OPC)
- 17. Handlebar
- 18. Cutting/Cylinder Lever
- 19. Drive Lever
- 20. Throttle Lever
- 21. Parking Brake Lever

4. Machine Overview

15. Start Switch

The start switch is used for starting, and maintaining power, to the machine.

Toggle to the **on** position prior to pulling the starter grip. This opens the grounding circuit for the spark plug to fire.

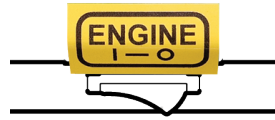

Fig. 5A - Start button

Toggle to the **off** position whenever the machine is not in use, or if immediate cut of power is required. This grounds the ignition coil, preventing the ignition coil sending a voltage to the spark plug.

16. Operator Presence Control (OPC)

This lever mechanism is a safety feature to prevent accidents. It signals to the machine of your control, active or otherwise, and either supplies or stops power to the cylinder, respectively.

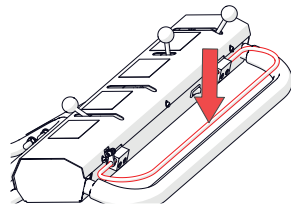

Fig. 5B - OPC

The OPC requires continuous engagement for the cylinder to be used. When used with the cylinder lever in the engaged position, it powers the cylinder clutch.

When the OPC is released, this indicates you are no longer present or in control. At this, the machine immediately ceases all power to the cylinder, regardless of lever position. This minimises risk caused by the machine being able to operate unattended or in unsafe conditions.



DANGER - BYPASSING OPC

Never interfere or tamper with the OPC in any way. This includes taping, tying up, altering the micro switch etc. Doing so bypasses a key safety mechanism of the machine and puts you and fellow pedestrians at risk.

18. Cutting/Cylinder Lever

This lever either engages/disengages power to the cylinder. Push forward to engage (i.e. start spinning), or pull back to disengage (i.e. stop spinning). Only engage when the machine is on grass and is safe to do so.

19. Drive Lever

This lever either engages/disengages power to the rear roller. Push forward to engage (i.e. start moving forward), or pull back to disengage (i.e. stop moving). Only engage when it is safe to do so.

20. Throttle Lever

This lever activates the speed of the machine. Push forward to engage tortoise (i.e. slow), pull back to engage hare (i.e. fast). The lever is proportional, therefore speed will alter depending on where it is positioned between the two. Choose the speed appropriate to the environment.

21. Parking Brake Lever

The mechanical parking brake physically stops the rotation of the rear roller driveshaft when engaged. This stops any unintended rolling and to be used when the machine is not in use. Push forward to engage (i.e. park brake on), or pull back to disengage (i.e. park brake off).



CAUTION - PARKING BRAKE

- **Always** engage the parking brake when the machine is not in use.
- Do **not** use the parking brake to stop the machine while moving. This may result in damage to the braking system. To stop, release the OPC and the machine will slow to a stop.

4. Machine Overview

4.4. Engine Components

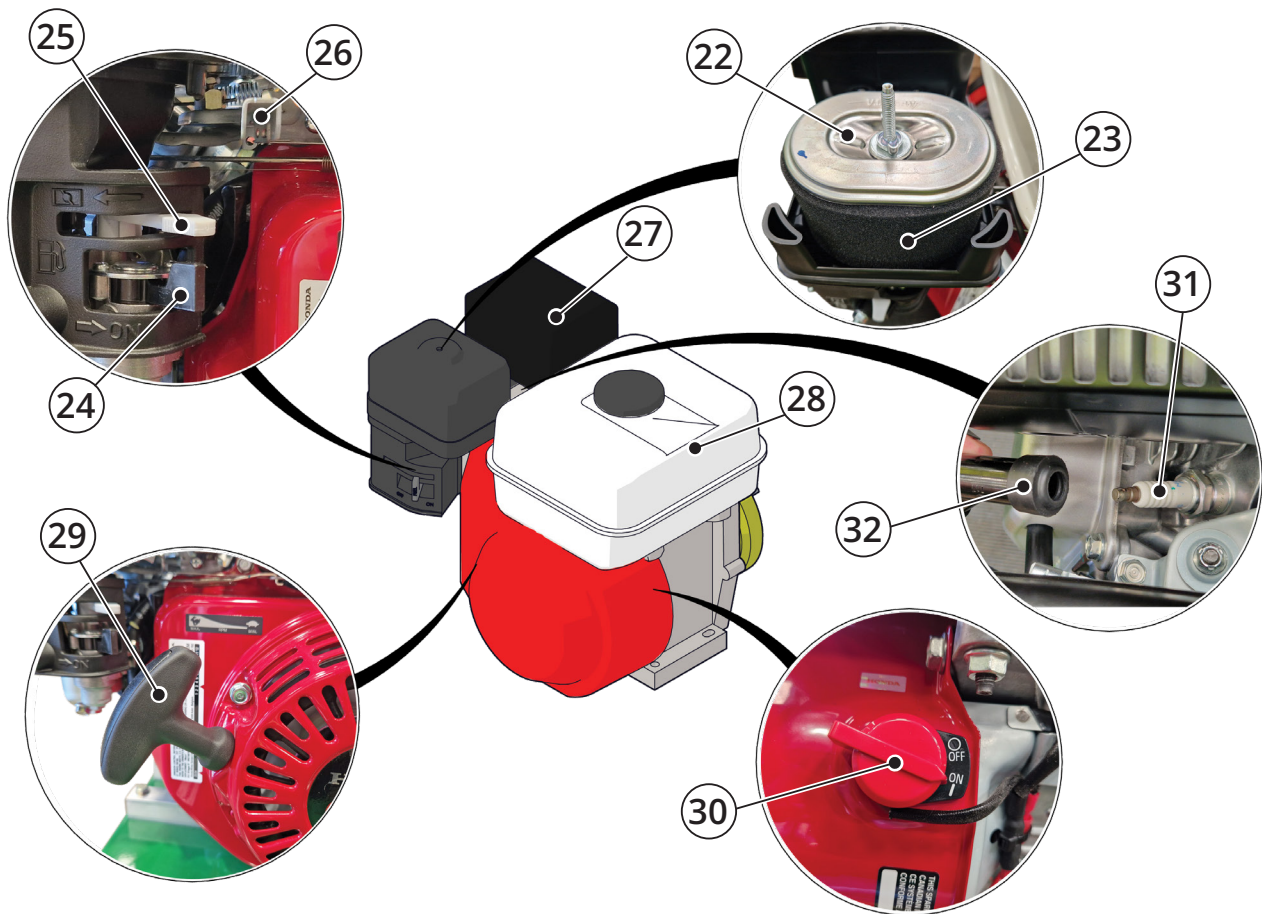

Fig.5. Engine components overview.

- | | |
|-----------------------------|----------------------|
| 22. Air Filter (paper) | 28. Fuel Tank |
| 23. Air Filter (foam cover) | 29. Starter Grip |
| 24. Fuel Lever | 30. Engine On/Off |
| 25. Choke Lever | 31. Spark Plug |
| 26. Throttle Control Lever | 32. Spark Plug Cover |
| 27. Exhaust | |

Please refer to supplied OEM 'Owner's Manual' for description and use of each of the above components.

5. Operation and Emergency Procedures

5.1. Pre-Start and Safety Checks



DANGER - OPERATING RISKS

- Prior to using the machine, ensure you read and understand this Operator Manual carefully. Failure to do so may result in injury and damage to the machine.
- Moving parts can cause serious injury. Keep hands, feet and clothing clear of moving components, particularly the cylinder and rollers. Contact with moving parts will cause severe personal injury or amputation.
- Before turning the engine on, you *must* ensure the area is clear of people and obstacles, and all safety guards are present.
- Hearing protection must be worn prior and during use with the engine *on*.



WARNING - MAINTENANCE CHECKS

Before using the machine, ensure all maintenance checks are complete, as per "6.1. Maintenance Schedule" p.36.



WARNING - SAFE OPERATING ENVIRONMENT

Always assess the job prior to starting. See "5.8. Operating Environment" p.33 for further information.

5.2. Cutting Preparation



WARNING - CYLINDER SAFETY

Always turn the machine *off* before adjusting any part of the cylinder or shear blade. Failure to do so creates a very high risk of cutting or amputation. *Always* wear hand protection.

5.2.1. Adjust Height of Cut

Cut height is adjusted using the supplied setting bar and basic tools.



NOTE - HEIGHT OF CUT

- When adjusting both the height of cut and the shear blade setting, always set the shear blade **first** before modifying the height of cut. Doing the opposite way may result in a different height of cut than planned.
- Remember height of cut is affected by moisture of turf, weight of the machine and thatch density. It is advised to set the height a little higher than your preference and reduce height by trial.

Tools required:

- 19 mm spanner
 - Rule
 - Setting bar
1. Turn the engine off (Fig. 6A).
 2. Remove the grassbox and fold the carry frame up.
 3. On the setting bar, adjust the bolt against the rule until the distance between the base of the bolt head and rule is that of the desired grass length. Secure with the nut [19 mm spanner] (Fig. 6B).
 4. Tip the machine gently back so it rests on the rear roller and handlebar (Fig. 6C).

5. Operation and Emergency Procedures

5. Two positions along the cylinder are required to be measured and adjusted to result in an even cut. Choosing either end of the cylinder first, lay the setting bar across the front and rear roller. Correct height is achieved when the underside of the bolt head rests, or is level with, the lip of the shear blade (Fig. 6D). If it already is, then no further adjustment is needed. If not, then continue with step 6.
6. Loosen the top clamp nut of the roller quadrant [19 mm spanner] (Fig. 6E). Repeat on the opposite side quadrant.
7. Rotate the toothed gear to raise or lower the front roller. While doing this, position up the setting bar again between the front and rear roller. Stop adjusting when the head rests within the lip of the shear blade (Fig. 6F). Tighten lightly the top clamp nut.
8. Repeat step 7 for the second position on the other side of the cylinder (Fig. 6G).
9. Check the setting bar again for both sides. Adjust if necessary. Once at the desired height, tighten both top clamp nuts.
10. Lift the machine gently up to rest on its front and rear rollers. Unfold the grass box carry frame and return the grass box.
11. Normal use can now be resumed.

Fig.6. Adjusting Height of Cut

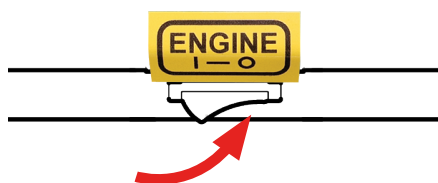

Fig. 6A - Turn the machine off.

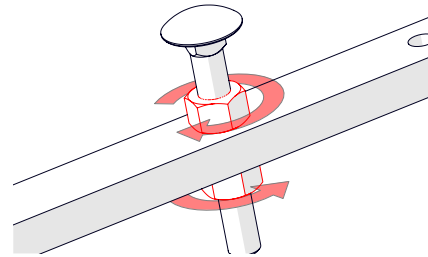
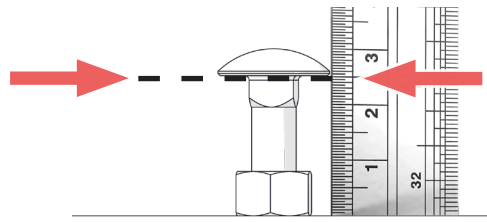

Fig. 6B - Adjust bolt to desired cut height and secure nut (above example set for 25 mm)

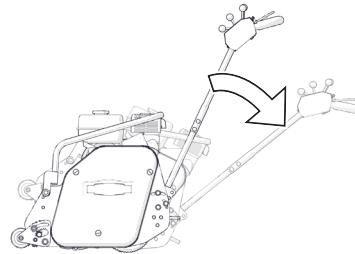

Fig. 6C - Gently tip the machine back

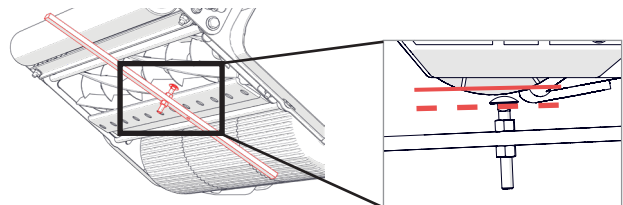

Fig. 6D - Position the setting bar and observe distance between the top of the shear blade and bottom on the bolt head. In this example, the bolt head is below the shear blade, indicating the machine cut height is currently too high and therefore needs lowering.

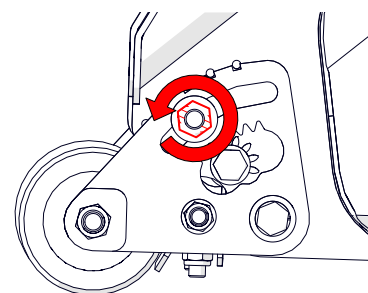

Fig. 6E - Loosen the top clamp nut of the roller quadrant

5. Operation and Emergency Procedures

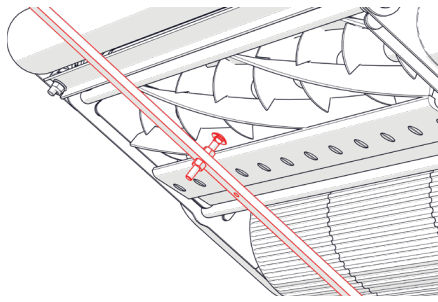

Fig. 6G - Repeat process on the other side

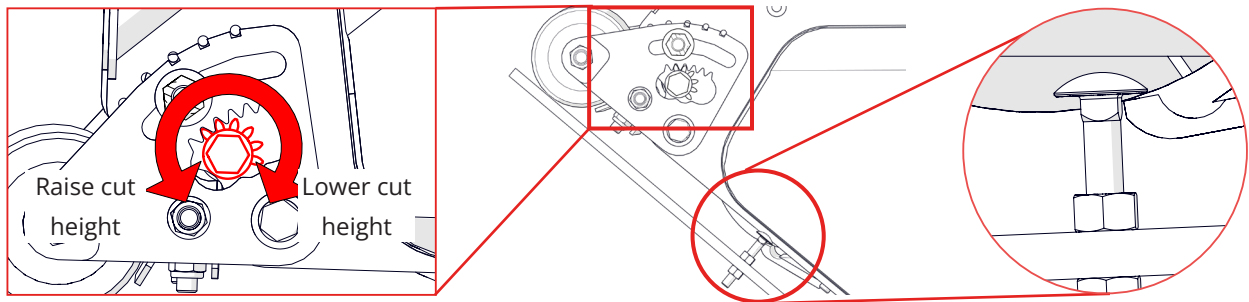

Fig. 6F - Rotate the toothed gear while offering up the setting bar. Stop when the head rests level/within the shear blade

5. Operation and Emergency Procedures

5.2.2. Handlebar Height Adjustment

Tools required:

- 2 x 19 mm spanner
1. Turn the machine **off**.
 2. Choosing either side of the machine, locate the two nuts at the bottom of handlebar and loosen [19 mm spanner] (Fig. 7A & 7B). Secure the outer bolt head while doing so [19 mm spanner].
 3. Repeat with the other side.
 4. Adjust the handlebar to the desired height.
 5. When set, tighten the 4 x inner nuts.

Fig.7. Handlebar adjustment

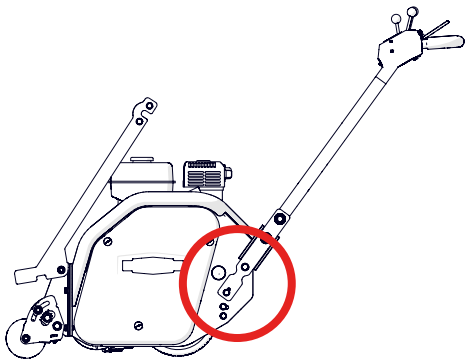

Fig. 7A - Securing the bolt head

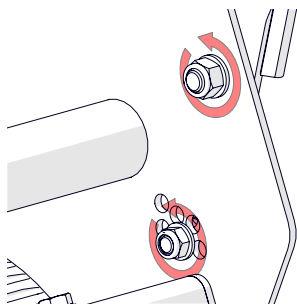

Fig. 7B - Loosening the inner nut

5.2.3. Shear Blade Adjustment



CAUTION - RISK OF INJURY

- **Always** turn the machine **off** before commencing this task.
- **Always** wear protective gloves to reduce risk of cuts and finger trapping.



NOTE - ORDER OF ADJUSTMENT

If planning on adjusting the height of cut at the same time, always adjust the shear blade first then adjust the height of cut. Doing the opposite way may result in a different height of cut.

Tools required:

- Scrap paper
 - 2 x 19 mm spanner
1. Turn the machine **off** and disengage the cutting and drive levers.
 2. Remove the grassbox and fold the carry frame up.
 3. Tip the machine gently back so it rests on the rear roller and handlebar. Chock the rear roller to stop unintended rolling (Fig. 8A).
 4. Choosing the left or right hand side of the cylinder, test the cut by moving the cylinder blade with a gloved hand and using a piece of paper between the cylinder and shear blade (Fig. 8B). If it does not cut the paper, or does not cut cleanly, then adjustment of the shear blade is required - see step 5. If it does cut cleanly, repeat test on the other side before proceeding to step 5 if required.
 5. Located at each end of a cylinder are two shear blade adjusters. On the side being adjusted, loosen the lock nut [19 mm spanner] (Fig. 8C).
 6. Adjust the gap with the adjustment nut

5. Operation and Emergency Procedures

[19 mm spanner] (Fig. 8D). Only very small adjustments are required - start with 1/8 of a turn and repeat the paper cut test. Repeat adjustment until the paper cuts cleanly.



NOTE - ADJUSTMENT DIRECTION

A sticker next to the adjuster informs of direction:

- ON = Decrease gap (i.e. cut 'on'),
- OFF = Increase gap (i.e. cut 'off').

7. Secure the lock nut.
8. Repeat step 6 on the opposite side.
9. Repeat the paper cut test on both sides. Adjust where necessary.
10. Lift the machine gently up to rest on its front and rear rollers. Unfold the grass carrier.
11. The machine is now ready for use.

Fig.8. Shearblade adjustment

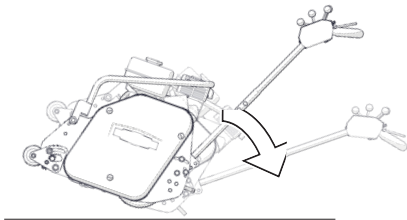

Fig. 8A - Tip to rest of handlebars

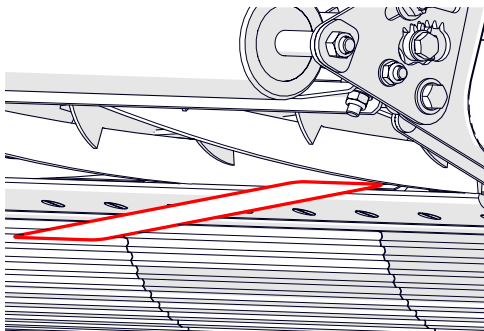

Fig. 8B - Repeating adjustment for other side

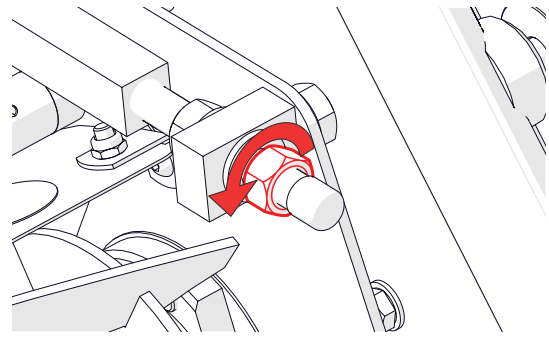

Fig. 8C - Loosen the lock nut

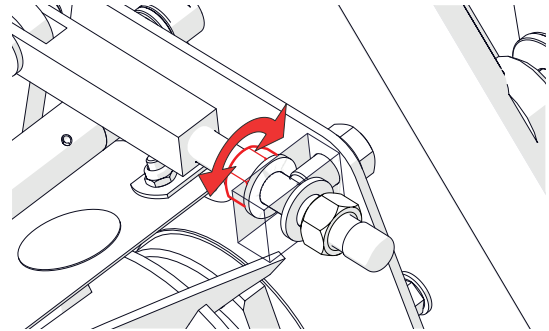

Fig. 8D - Tighten/loosen the adjustment nut

5. Operation and Emergency Procedures

5.3. Engine

5.3.1. Safety Information



WARNING - ENGINE SAFETY

- **Always** read the safety instructions in "2.3.2. Engine and Fuel Safety Instructions" p.7.
- This manual includes general guidance for the operation and maintenance of the engine. Always read the OEM engine 'Owner's Manual' provided for specific instructions and safety information not covered in this manual.
- Allow the engine to idle for a short time before driving, especially in cold weather.

5.3.2. Refuelling



WARNING - REFUELLING

Note the following for correct and safe refuelling use:

- Turn off the engine and allow it to cool before refuelling.
- Avoid smoking or using any ignition sources near the refuelling area.
- Refuel outdoors or in a well ventilated area.
- Only refuel using unleaded petrol (pump octane rating 86 or higher).
- Fill to no further than the neck of the tank.

5.3.3. Installation and Removal

The engine is supplied mounted to the chassis on engine bearers. During normal use, there is no expectation to remove the engine. However, if the engine is required to be removed entirely:

1. Turn the machine **off** from both the start switch (located with the control components) and the engine on/off switch.
2. If the engine is being removed permanently, remove all fuel and oil with a syphon pump or similar. If the engine is being removed temporarily, ensure the fuel cap and oil plug are secure.
3. Remove the 4 x M8 hex bolts securing the engine to the engine bearings [13 mm spanner].
4. Slide the engine towards the right hand side of the machine - this will disconnect the engine coupling from the driveshaft.

5.3.4. Engine Specifications

For engine specification, see "4.1.2. Specification Table" p.14 and within the supplied OEM manual for the engine.

5.3.5. Replacement and Disposal

Should the engine require disposal, follow the points in "6.6. Disposal" on page 53.

5. Operation and Emergency Procedures

5.4. Starting the Engine

To turn your engine **on**:

1. Set the parking brake to the **on** position (Fig. 9A).
2. Set the engine switch (located on the engine) to the **on** position (Fig. 9B).
3. Set the fuel lever to the **open** position (towards the front) (Fig. 9C).
4. Set the choke lever to the **closed** position (towards the rear) (Fig. 9D). Note, setting the choke to this position is not required if the engine is warm or the air temperature is high.
5. Press the start switch (located with the control components) to the **on** position (Fig. 9E).
6. Set the throttle lever to the **half-way** position (Fig. 9F).
7. Grasp the starter grip handle and extend until the slack is removed. At this point, pull with a steady and fluid motion (Fig. 9G). The engine will start.



NOTE - ENGINE START

Ensure the cylinder and drive levers are both in the disengaged position before starting the engine. As a safety precaution, the machine will not start with these in the engaged position.

8. Allow the starter grip handle to return gently, avoid releasing it to 'snap' back into position.
9. Gradually move the choke lever into the **open** position (towards the front) (Fig. 9H). Leave to warm up for 3-5 minutes while gradually moving the throttle to the tortoise position.

Fig.9. Power on procedure

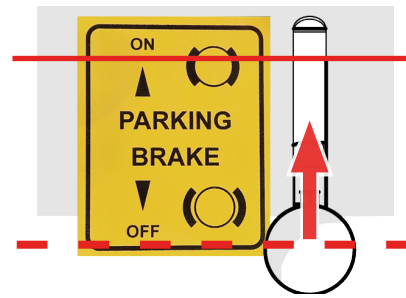

Fig. 9A - Parking brake on.



Fig. 9B - Engine switch on.

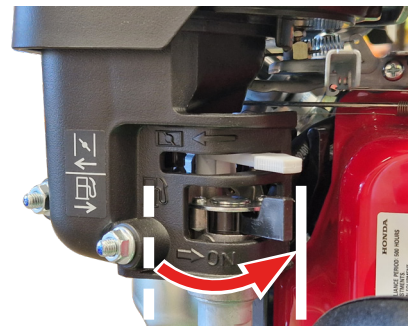

Fig. 9C - Fuel lever open.

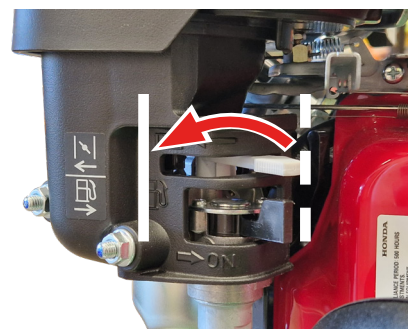

Fig. 9D - Choke lever closed.

5. Operation and Emergency Procedures

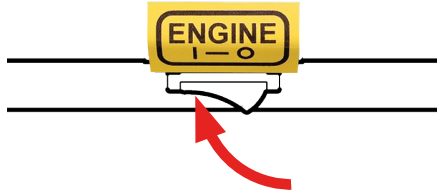

Fig. 9E - Start switch on.

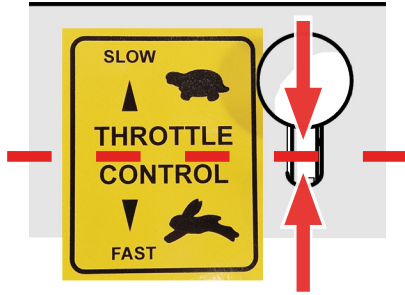

Fig. 9F - Throttle set half-way

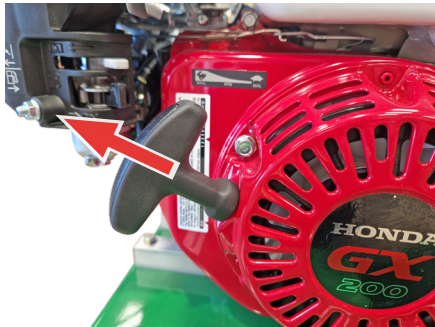

Fig. 9G - Pull starter grip handle.

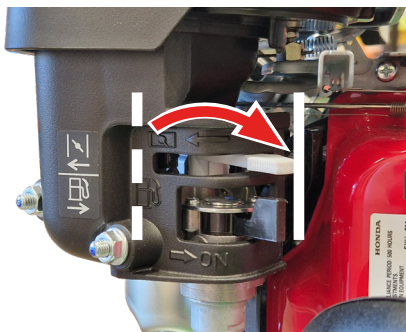

Fig. 9H - Move choke lever into open position.

5. Operation and Emergency Procedures

5.5. Stopping the Engine

To turn your machine *off*:

1. Move the throttle lever fully to the *low* (tortoise) position (Fig. 10A).
2. Press the start switch (located with the control components) to the *off* position (Fig. 10B).
3. Set the fuel lever to the *closed* position (towards the rear) (Fig. 10C).

Fig.10. Power off procedure

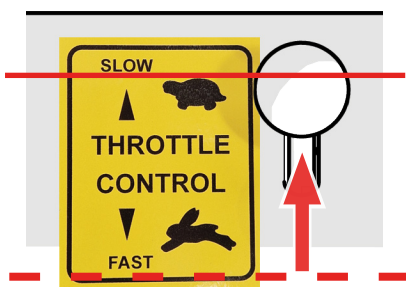

Fig. 10A - Throttle set to low

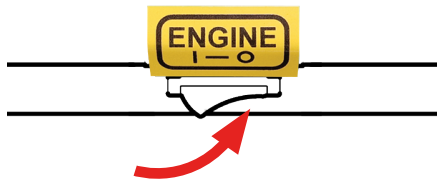

Fig. 10B - Start switch off

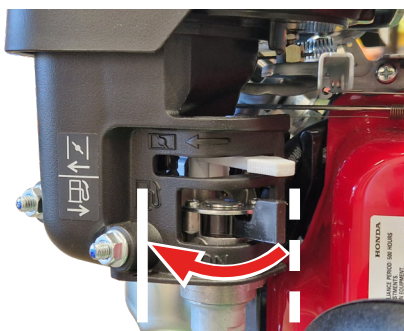

Fig. 10C -

In emergency situations, turn either the start switch or engine switch to the *off* position.

5.6. Drive

5.6.1. Moving and Transport (no cut)



CAUTION - HANDLEBAR HEIGHT

Prior to moving the machine, set handlebar to the correct height. See "5.2.2. Handlebar Height Adjustment" p.24.

1. Start the engine as per "5.4. Starting the Engine" p.27.
2. Release the parking brake (*off* position).
3. Set the throttle to tortoise speed.
4. Depress the OPC (Fig.11A).
5. Push the Drive Lever *forwards* to *engage* drive (Fig. 11B). Do this slowly to allow the clutch to ease into position.
6. Adjust the Throttle Lever to increase speed if desired (Fig. 11C).
7. To *stop*, pull the Drive Lever towards the rear to the 'disengage' position (Fig. 11D).



NOTE - ENGINE STOP

Depressing the OPC while keeping the park brake on will result in the engine stopping. Following the order above will stop this happening.



NOTE - DRIVING OVER HARD GROUND

When driving over ground other than grass, tilt the machine backward to elevate the front roller, ensuring it travels solely on its rear roller. This avoids potential damage to the cylinder and blades.

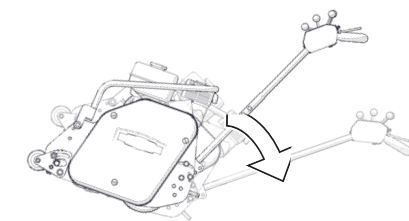

5. Operation and Emergency Procedures

Fig.11. Driving procedure

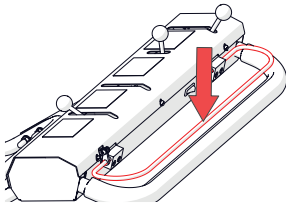

Fig. 11A - Depress the OPC.

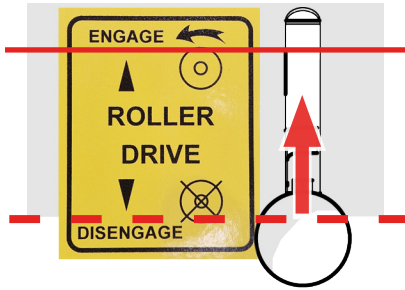

Fig. 11B - Engage the drive lever.



Fig. 11C - Adjust the throttle lever.

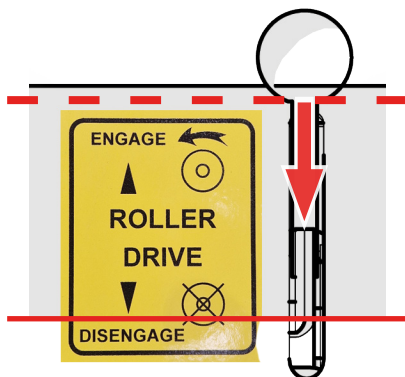

Fig. 11D - Disengage the drive lever.

5.6.2. Operating on Slopes



WARNING - SLOPES

The machine operates best on flat ground. Follow the safety points below when operating on slopes:

- Slopes can tip a machine over. Observe extreme caution. Check for obstacles or anything that may lead to instability (e.g. dips, bumps, uneven ground) prior to operating.
- There is no maximum operating machine slope angle; use personal judgement, taking into account surrounding environment and weather. If in any doubt, do not use on a slope.
- Operate across the face of a slope, never up and down.
- Avoid when wet as this can increase the risk of an accident occurring.
- Go slow; speed can increase the risk of an accident occurring. Take extra care when turning.

5. Operation and Emergency Procedures

5.7. Cutting

5.7.1. Moving and Cutting



WARNING - ROTATING BLADES AND MOVING PARTS

- Blades, brushes and rollers can continue to rotate even after the motor has stopped.
- *Never* lift or carry a machine whilst any parts are moving.
- *Always* wait for the cylinder to stop rotating before travelling over anything that is not grass.
- *Never* carry out adjustments whilst the machine is running.



NOTE - HEIGHT OF CUT

Prior to cutting, set the cylinder to the correct height. See "5.2.1. Adjust Height of Cut" p.21.

1. Start the engine as per "5.4. Starting the Engine" p.27.
2. Release the parking brake (off position).
3. Set the throttle to tortoise speed.
4. Depress the OPC (Fig. 12A).
5. Push the Cylinder Lever *forwards* to *engage* the cylinder. Do this slowly to allow the clutch to ease into position (Fig. 12B).
6. Push the Drive Lever *forwards* to *engage* drive. Do this slowly to allow the clutch to ease into position (Fig. 12C).
7. Adjust the Throttle Lever to increase speed if desired (Fig. 12D). Push forward to engage tortoise (i.e. slow), pull back to engage hare (i.e. fast). The lever is proportional, therefore speed will alter depending on where it is positioned between the two.
8. To *stop moving*, pull the Drive Lever towards the rear to the 'disengage' position - the cylinder will continue to spin if the OPC is also depressed (Fig. 12E).

9. To *stop the cylinder spinning*, pull the Cylinder Lever towards the rear to the 'disengage' position. Alternatively, release the OPC (Fig. 12F).

Fig.12. Cutting procedure

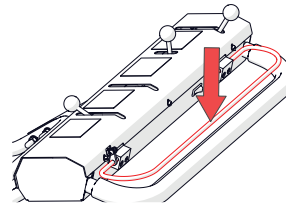

Fig. 12A - Depress the OPC.

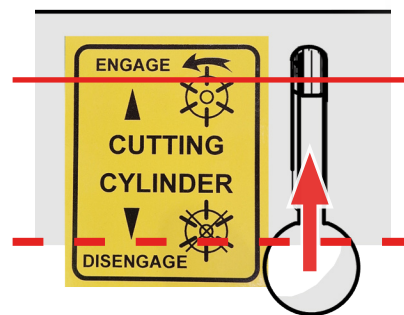

Fig. 12B - Engage the cylinder lever.

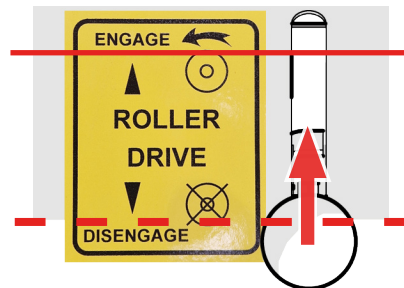

Fig. 12C - Engage the drive lever.



Fig. 12D - Adjust the throttle lever.

5. Operation and Emergency Procedures

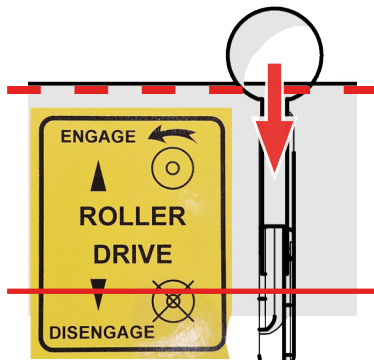

Fig. 12E - Disengage the drive lever.

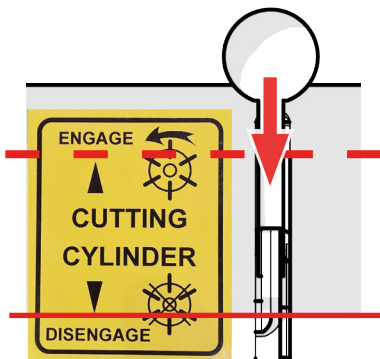

Fig. 12F - Disengage the cylinder lever.

5.7.2. Cutting Technique

There is no set technique for cutting as it will suit individual circumstances. However we recommend the following:

- Mow in straight lines - turning while cutting may damage the turf and produce an inferior quality of cut.
- To perform a turn, press the handlebar down to lift the front of the machine before applying force to the left/right side. The three part differential rear roller allows for easier and tighter turning.
- Mow at a standard walking space - alter the throttle speed accordingly to achieve this.
- Do not cut for too long in a single spot or without cutting grass. This can damage the grass and increase blade wear.
- Avoid cutting more than one third of the grass blade. Doing so can increase the risk of disease and stress for the plant.

5. Operation and Emergency Procedures

5.8. Operating Environment



CAUTION - ENVIRONMENTAL CONDITIONS

Failure to observe the conditions listed below may result in a risk to the operator and damage to the machine.

Refer to the OEM engine 'Owner's Manual' for further information.

Temperature:

- Use between -20 to +40°C*. However usage in the upper and lower limits of this range will affect performance and engine life.
- Operators must take necessary precautions against temperature, such as sun protection and suitable clothing.

**The machine can operate beyond the temperature range optimum for grass cutting. Grass is best cut between 10-30°C.*

Weather:

- Use in dry conditions wherever possible. Do not use on excessively wet or frozen ground. This avoids damage to motor components and traction hazards caused from slippery grass.
- Cutting wet grass leads to poorer cut quality, clumping and reduced collection into the grass bag. This results in additional cleaning of the machine.
- Compaction of the soil is more likely with wet weather.
- Do not use in adverse weather conditions (e.g. storms, high wind, risk of lightning etc).
- Operators must take necessary precautions against the weather, such as sun protection and suitable clothing.

Terrain/Slope:

- Ensure the ground is firm and preferably dry. Soft or wet ground can cause manoeuvrability problems.
- There is no maximum slope angle, however use professional judgement when using on slopes (see "5.6.2. Operating on Slopes" p.30.)
- Before use, check to ensure the terrain is free from obstacles and obstructions, including rocks, branches and debris.

Humidity:

- Use between 30–70% RH. High humidity can lead to rust and corrosion on metal parts, and to fungal diseases on the grass after cutting.
- Low humidity can lead to wilting and browning of the grass after cutting.

Dust and particulate:

- Avoid dusty or sandy conditions. Such environments can damage the machine and be hazardous to the operator.

Vibration and Shock:

- Keep vibration and shock to a minimum to avoid damage to machine components. This includes, bumps, pot holes and kerbs.
- Store the machine away from passing traffic and avoid transporting over rough ground - lower gently over kerbs or use alternative routes.

Lighting Conditions:

- Use the machine in good lighting conditions, either natural or artificial. This allows for the safe operation of the machine.

Safety Zones:

- Other than the operator, all other personnel must keep their distance from the machine during use. This must be maintained by the operator to keep the zone free.

5. Operation and Emergency Procedures

5.9. Emergency Procedures

5.9.1. In the Event of a Breakdown



WARNING - MACHINE BREAKDOWN

- Take full care and attention while investigating the cause of a fault. Where possible, wear suitable PPE including gloves and safety glasses.
- Never touch leaked materials, avoiding contact with skin and eyes. Rinse immediately with water and seek medical attention if necessary.
- Secure the working area with appropriate warning notices.
- In case of a petrol spill, clean it up immediately using appropriate absorbent materials.

Regular service and maintenance will prevent the majority of machine breakdowns. The below procedure outlines the immediate actions if the machine fails to function entirely. If the machine is not working as intended and a minor issue, refer to "6.7. Troubleshooting & FAQ" p.53.

In the event of a breakdown:

1. Turn the machine **off** from both the start switch (located with the control components) and the engine on/off switch.
2. Disconnect the spark plug by holding between the thumb and fore-finger and pulling away. This prevents accidental engine starting.
3. If possible, move the machine to a safe area where further investigation can be carried out. If the machine cannot be moved, clearly label it as 'faulty' and cordon around the machine to mitigate unauthorised personnel from accessing the machine.
4. If there are fuel leaks, immediately clean up and adsorb with appropriate materials.
5. Once in a safe area or in a serviceable state, inspect the machine for any obvious defects.

Do not attempt repairs beyond basic troubleshooting unless qualified. Full repairs to be carried out by qualified service engineer and documented accordingly.

6. If the source of the breakdown cannot be found, contact your Dealer or Dennis for further information.

5.9.2. Hazardous Substances and Fire



WARNING - HAZARDOUS SUBSTANCES

- Always operate and refuel the lawnmower outdoors or in well-ventilated areas - never operate the engine in enclosed spaces. Avoid inhaling exhaust fumes.
- Wear appropriate PPE, such as gloves and safety glasses, when handling petrol.
- Dispose of petrol and contaminated materials in accordance with local regulations.

When operating the lawnmower, the combustion of petrol in the engine produces several emissions that may be hazardous to health and the environment. This includes predominantly:

- Carbon Monoxide (CO): A toxic, odourless gas that can cause dizziness and headaches,
- Nitrogen Oxides (NO_x): Can irritate the respiratory system,
- Other emissions include Carbon Dioxide (CO₂), unburned hydrocarbons, particulate matter and Volatile Organic Compounds (VOCs).

Operating outdoors or in well ventilated area will reduce this risk.

5. Operation and Emergency Procedures



WARNING - HANDLING PETROL AND FIRE PREVENTION

Note the following when working and handling petrol:

- Always use approved containers for petrol storage.
 - Store petrol in a cool, well-ventilated area away from open flames or sparks.
 - Avoid overfilling the fuel tank to prevent spills.
 - Keep the area immediately around the engine and exhaust free of grass and debris to prevent fire hazards.
 - Regularly inspect the machine for fuel leaks. Repair any found immediately and prior to use.
-

In the event of a fire involving the machine or fuel:

- Stop the engine immediately (if safe to do so).
- Evacuate the area and ensure all persons are at a safe distance.
- Do not attempt to move the machine if it is on fire.
- Call Emergency Services if the fire cannot be quickly and safely controlled.
- Use a Class B fire extinguisher, which is designed for flammable liquids such as petrol.

Important: Only attempt to extinguish the fire if you are trained and it is safe to do so. Personal safety must always come first.

6. Maintenance and Service

6.1. Maintenance Schedule



WARNING - CORRECT MAINTENANCE

- Following the schedule set out below will prolong the life of your machine and deliver high performance.
- Failure to carry out these checks at the specified intervals will result in damage to your machine and possible injury to personnel. If you are unsure of anything, contact Dennis or your Dealer.
- Not servicing your machine correctly will invalidate your warranty. See "6.8. Warranty Policy" p.53 for more information.
- Always use genuine Dennis/Honda parts when servicing and replacement.

The following checks must be actioned as per date or running hours, whichever comes first. Ensure checks are performed in an appropriate area (such as a storage shed), and not on the playing surface due to risk of containments/ petrol/oil. Complete checks with the engine *off* and when following 'Post-use', check only when the engine has cooled.

Checks regarding the petrol engine must be in conjunction with the maintenance items in the OEM manual. Where maintenance intervals differ, always follow the more frequent schedule to ensure optimal performance and warranty compliance.

Service kits are available for the machine - see "Appendix B. Service Kit" p.56.

Maintenance and Safety Checks	Daily		Weekly 25hr	Monthly 100hr	6-monthly 600hr	Annually 1200hrs
	Pre-use	Post-use				
Engine						
Check engine oil level is between upper and lower limit.	•					
Check air filter for dirt or damage. Remove any debris.	•					
Check fuel level is enough for intended use (do no overfill past the neck). Clean all grass/debris around the neck first to avoid contaminating the fuel.	•					
Check condition of the entire engine (including driveshaft guards) following for signs of damage. Do not use if anything is damaged.	•	•				
Clean off all grass cuttings/debris from the entire engine using an air-hose, brush or similar. This includes: fuel tank, air filter, starter grip and exhaust. Failure to clean will increase fire risk.	•	•				
Measure engine speed with tachometer. Speed must be 2800 rpm (±50 rpm) at full throttle. Adjust accordingly (see 'Idle speed' in engine Owner's Manual).					•	

6. Maintenance and Service

Maintenance and Safety Checks	Daily		Weekly 25hr	Monthly 100hr	6-monthly 600hr	Annually 1200hrs
	Pre-use	Post-use				
Change engine oil (20 hours first change).	Refer to engine Owner's Manual					
Clean sediment cup.						
Check/clean spark plug.						
Remove air filter cover and clean debris from base of filter.						
Remove air filter cover and remove outer foam filter and wash in warm, soapy water. Ensure thoroughly dry before returning. Replace if damaged.						
Remove air filter cover and clean debris from around the paper filter by tapping several times on a hard surface. Replace if excessively dirty or damaged.						
Check/adjust valve clearance*.						
Clean fuel tank and strainer*.						
Check fuel line. Replace if necessary*.						
Cylinder 						
Check cylinder and shear blade for wear or damage (impact, dents, material cracking and excessive thinning). Replace or re-grind worn blades. Replace damaged blades.	•					
Check the blades spin freely, with no grinding or metal-on-metal contact noises (<i>always</i> turn the machine <i>off</i> first).	•					
Check the quality of cut. Adjust the shear blade if required.	•					
Grease cylinder bearings ¹ .			•			
Apply a small amount of grease to shear blade adjuster rods ¹ .			•			
Adjust the metal deflector.	<i>As required</i>					
Chassis						
Check all guards are fitted correctly.	•					
Visually check all fixings (secure and in place).	•					
Check the cutting height is set correctly.	•					
Check the grass box is fitted correctly.	•					
Clean off all grass cuttings from bodywork.		•				

6. Maintenance and Service

Maintenance and Safety Checks	Daily		Weekly 25hr	Monthly 100hr	6-monthly 600hr	Annually 1200hrs
	Pre-use	Post-use				
 Clean off all grass cuttings from the cylinder blade (ensure the machine is turned off first. Use a long handled brush).		•				
Check front roller bushes and bearings for wear. Replace if necessary.			•			
Grease rear roller internal spur gear ¹ .			•			
Remove belt guard and visually check condition of drive belts. Adjust/replace if required (<i>check within first 20hrs and after replacement</i>).				•		
Apply a small amount of oil to the control cables ¹ .					•	
Apply a small amount of copper grease to each control lever ¹ .					•	
Check condition of rear roller bearings and bushes. Replace if necessary.					•	
Renew oil in rear rollers ²						•
Controls						
Check the following for signs of damage and that they operate freely and as intended: <ul style="list-style-type: none"> • OPC • Start switch • All 'Control Component' levers by handlebar (x4): <ul style="list-style-type: none"> ◦ Parking brake operates brake caliper. ◦ Throttle lever moves the throttle control lever on the engine. ◦ Drive and Cutting Levers both operate their respective clutches. 	•					
Set the parking brake to on . Depress the OPC and try to start the engine - the engine must not start.	•					
Operate the OPC (engine off), ensure the 'click' is heard from its microswitch.	•					
With the engine running, tip the machine back slightly so the cylinder is raised above the ground. Depress the OPC and then engage the cylinder. Release the OPC - the cylinder must stop. If it does not, see " 6.7. Troubleshooting & FAQ " p.53.	•					

¹ See section "**6.2.8. Lubrication**" p.50. ² See section "**6.2.7. Changing Rear Roller Oil**" p.49.

*Authorised Honda dealer or mechanically proficient only.

6. Maintenance and Service

6.2. Servicing Instructions



WARNING - SAFETY

- You **must** turn the engine **off** before service work. Failure to do so may cause major injury.
- Always wear suitable PPE for the job at hand.



CAUTION - SERVICE LOCATION

When servicing the machine, position in a suitable environment for working on (for oil spills etc) and if planning leaving for extended periods.

6.2.1. Cylinder and Drive Belt Replacement/ Tensioning



CAUTION - BELT TENSIONING

Incorrect tensioning of a belt can lead to a range of issues and premature failure of components. Issues include slippage (resulting in poor power transmission), increased component wear, increased noise, increased stress on bearings and pulleys, pulley damage and many others.

New belts will stretch during the first hours of use and must be monitored regularly. Inspect after ~30 minutes to four hours operating under full load and re-tension accordingly.

After approximately 24 hours of operation, inspect and re-tension again.

Tools required:

- Slotted screwdriver
- Spanners: 10 mm, 17 mm and 9/16"
- Replacement belt (*if required, cylinder belt p/n 228030 (x2), drive belt p/n 228012*)

1. Turn the machine **off** and disengage both drive and cutting levers (Fig. 13A).
2. Remove 3 x outer screws of the belt guard [slotted screwdriver] (Fig. 13B) and keep to the side.
3. Cylinder Belt:
 - i. If re-tensioning only, skip to step iv. Remove the semi-circular belt guide by removing the two M6 bolts [10 mm spanner] (Fig. 13C).
 - ii. Hold the tensioner pulley away. Remove the belts and replace (Fig. 13D & 13E).
 - iii. Refit the belt guide but do not tighten.
 - iv. Engage the cutting lever - the tensioner pulley will make contact with the belts and put them under tension. Adjust the two nuts of the cable to achieve more or less tension on the belts (Fig. 13F). Turn the top pulley (by hand), the belts should move freely and turn the lower pulley accordingly (Fig. 13G). When the cutting lever is disengaged, the tensioner pulley will 'rest' on the belts and not provide any form of firm pressure (turning of the pulley does not result in the belt moving).
 - v. Test; replace the belt guard and secure with the outer screws (Fig. 13L). Disengage the cutting lever.
 - i. Turn the engine **on** and observe the cylinder - it must **not** rotate with the cutting lever in the disengaged position.
 - ii. Engage the cutting lever - the cylinder must engage and spin. Now disengage the cutting lever - the cylinder **must stop** within 7 seconds.
- If either of the above is not achieved then further adjustment of the tensioner pulley is required; Add more tension if the cylinder does not spin with the lever in the engaged position, reduce tension if the cylinder does not stop within the seven second period with the lever in the

6. Maintenance and Service

disengaged position (note guide peg warning message below). Re-test v.i and v.ii above.



WARNING - GUIDE PEG CONTACT

When in the *engaged* position, the tensioner pulley must *not* make contact with the guide peg (circled). See "6.2.9. Guide Peg Adjustment" p.51 for more information.

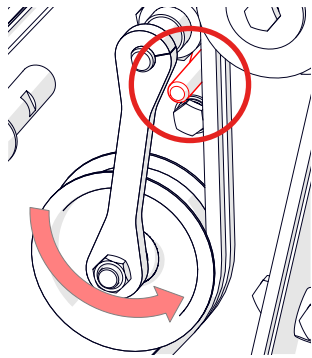

4. Drive Belt:

- i. If re-tensioning only, skip to step iii. Loosen the tensioner pulley [9/16" spanner] (Fig. 13H).
- ii. Hold the tensioner pulley away. Remove the belt and replace (if required) (Fig. 13I).
- iii. Adjust the tensioner pulley to add tension to the belt and tighten. Tension is tested by twisting the belt between thumb and forefinger on the longest straight section of belt. Achieve a twist between 70–90° (Fig. 13J). Re-adjust the tensioner pulley if necessary, making more or less contact to achieve this value.

5. Attach the belt guard [slotted screwdriver].

6. The machine is now ready for use.

Fig.13. Drive belt replacement / tensioning

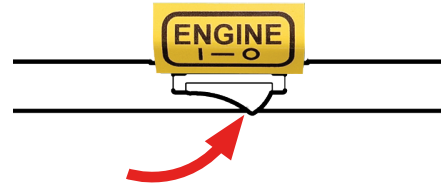

Fig. 13A - Turn the machine off.

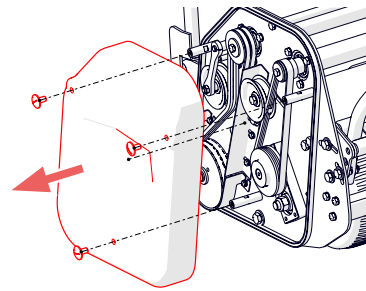

Fig. 13B - Remove 3 x outer screws and cover.

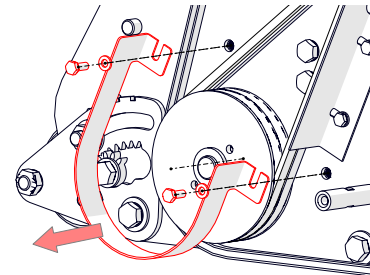

Fig. 13C - Remove the belt guide.

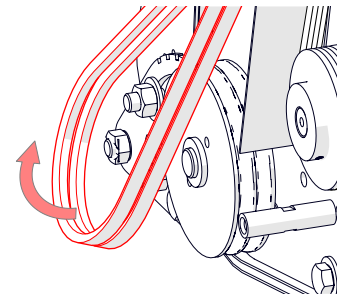

Fig. 13D - Remove and replace the belt.

6. Maintenance and Service

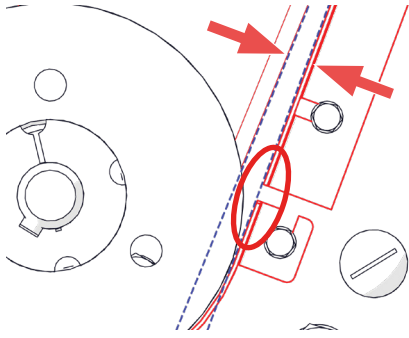

Fig. 13E - Ensure both belt guides are level (i.e.no step) (circled) and sufficient gap between the belt and belt guide (lines).

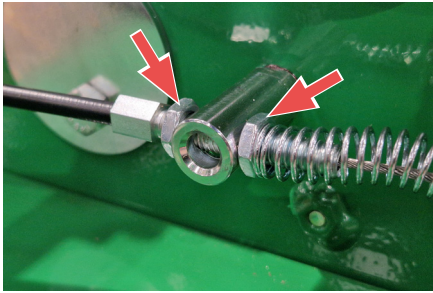

Fig. 13F - Tension by adjusting the nuts accordingly.

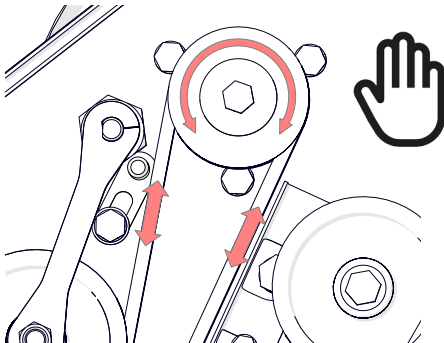

Fig. 13G - Check correct tension by moving the pulley by hand.

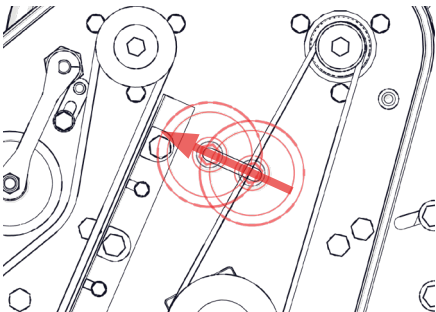

Fig. 13H - Loosen the tensioner pulley.

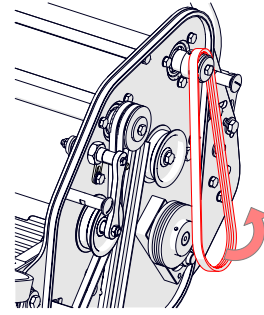

Fig. 13I - Remove and replace the belt.

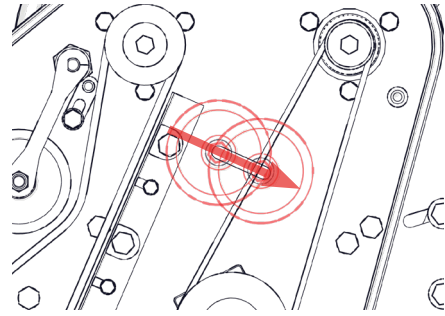

Fig. 13J - Adjust the pulley to add pressure to the belt.

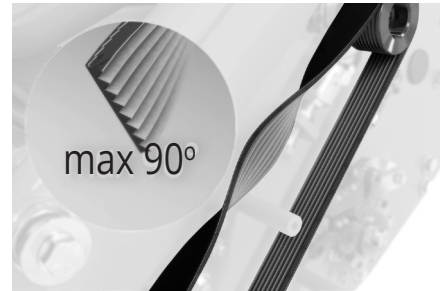

Fig. 13K - Correct pressure achieved when the belt twists 90°.

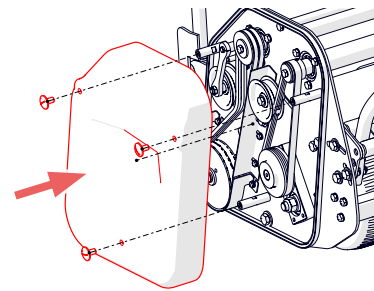

Fig. 13L - Reattach cover.

6. Maintenance and Service

6.2.2. Transmission Belt Replacement/ Tensioning

Tools required:

- Spanners: 10 mm, 13 mm and 24 mm
- Replacement belt (*if required, belt p/n 228007*)

1. Turn the machine **off** and disengage both drive and cutting levers.
2. Remove the 4 x M8 bolts securing the transmission guard [13 mm spanner] (Fig. 14A).
3. Remove the 4 x M8 hex bolts securing the engine to the engine bearings [13 mm spanner] (Fig. 14B).
4. Disconnect the earth [10 mm spanner] and ignition cables connecting to the engine (Fig. 14C).
5. Check the fuel cap and engine oil plug are secure. Slide the engine towards the right hand side of the machine and remove safely to the side (Fig. 14D).
6. Remove the 2 x M6 bolts securing the semi-circular belt guide [10 mm spanner] (Fig. 14).
7. Remove the brake disc [24 mm spanner] (Fig. 14F).
8. Remove the belts and replace (if required) (Fig. 14G).
9. Reassemble the brake disc [24 mm spanner] and belt guide [10 mm spanner].
10. Adjust the pulley so when the drive lever is in the disengaged position, it rests on the support bracket (Fig. 14H), avoiding as much contact with the belt as possible.
11. Engage the drive lever. Ensure that when the output shaft is turned (manually), the belt moves and turns the drive shaft pulley (Fig. 14I). Adjust the tension of the cable and arm to achieve this (Fig.14J). Adjusting tension will also alter the engagement point of the drive lever/pulley, resulting in a quicker or slower acceleration - adjust to suit preference.

12. Disengage the drive lever. Reinstall the engine by aligning the coupling of the output shaft and engine bearer bolt holes.
13. Secure the engine to the engine bearers [13 mm spanner].
14. Reinstall the transmission guard [13 mm spanner].
15. The machine is now ready to use.

Fig.14. Transmission belt adjustment

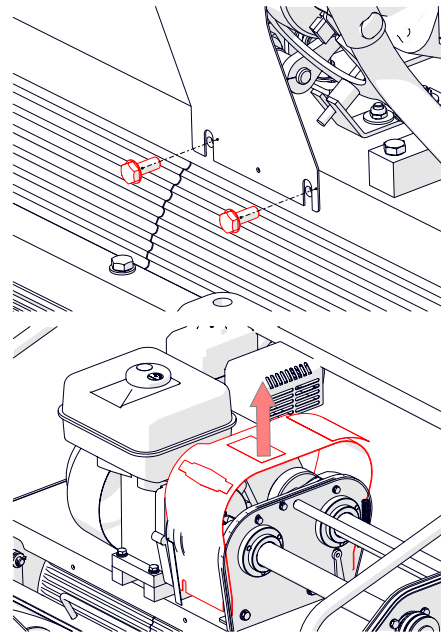

Fig. 14A - Transmission guard removal.

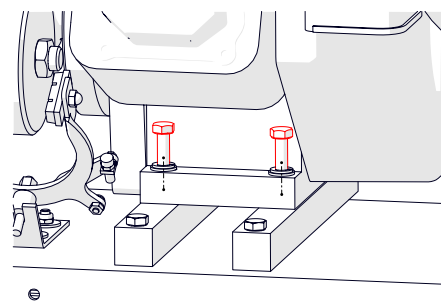

Fig. 14B - Remove engine bolts from bearers.

6. Maintenance and Service

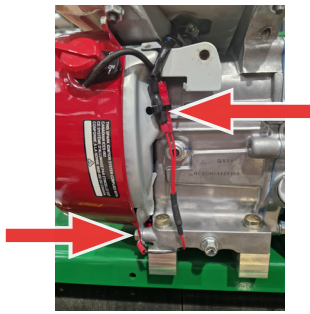

Fig. 14C - Disconnect cables to the engine.

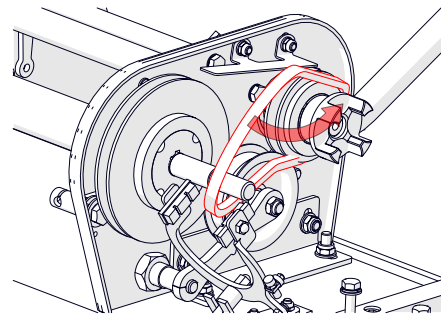

Fig. 14G - Replace drive belt.

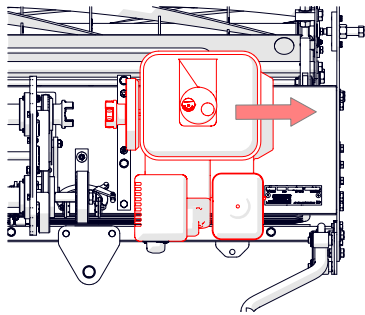

Fig. 14D - Slide engine away from coupling.

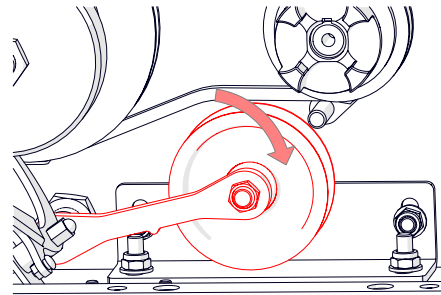

Fig. 14H - Adjust the pulley to avoid belt contact in disengaged state.

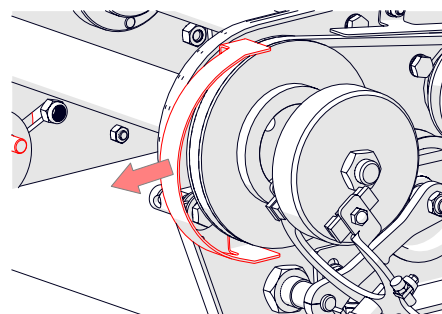
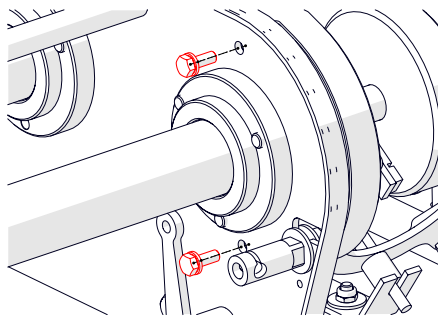

Fig. 14E - Remove bolts for belt guide.

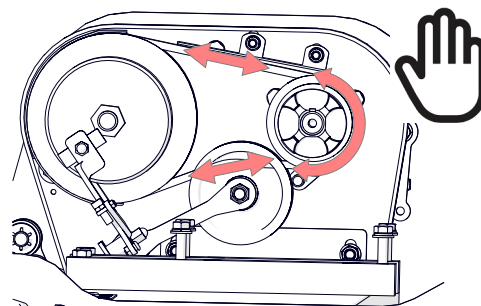

Fig. 14I - Check correct tension by moving the pulley by hand.

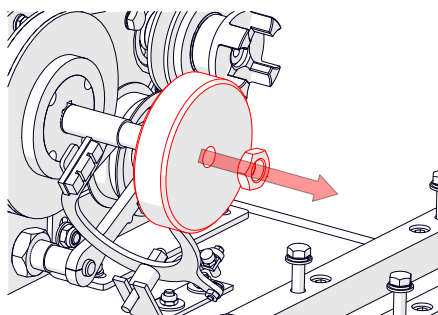

Fig. 14F - Remove brake disc.

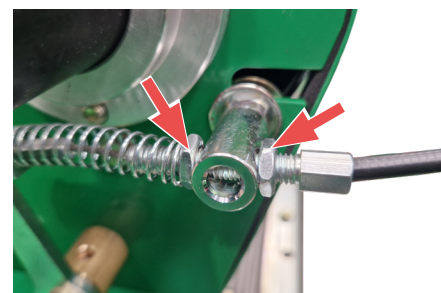

Fig. 14J - Tension by adjusting the nuts accordingly.

6. Maintenance and Service

6.2.3. Removing a Cylinder

Tools required:

- Slotted screwdriver
- Spanners: 10 mm, 19 mm, 3/4" and 5/16"
- 5 mm hex key



WARNING - PPE

Always wear suitable PPE, including eye protection and gloves.

1. Turn the machine **off** and disengage both drive and cutting levers.
2. Remove the grassbox and fold the frame up.
3. Tip the machine gently back so it rests on the rear roller and handlebar. Chock the rear roller to stop unintended rolling.
4. Bring a block of wood or similar underneath the cylinder, this will secure it when removed from the machine.
5. Remove 3 x outer screws of the belt guard [slotted screwdriver] (Fig. 15A) and keep the cover to the side.
6. Remove the semi-circular belt guide by removing the two M6 bolts [10 mm spanner] (Fig. 15B). Hold the tensioner pulley away. Remove the belts (Fig. 15C).
7. The cylinder pulley requires removing but is held by a tapered bush. Remove the two grub screws [5 mm hex key] and then insert one of those grub screws into the empty third opening - the tapered bush and cylinder pulley will separate. Remove the grub screw. Additional force may be required to slide the tapered bush off the cylinder shaft. (Fig. 15D).
8. Remove the top and bottom hex screws [3/4" spanner and 5/16" spanner] from each side securing the shear blade carrier (Fig. 15E & Fig. 15F). Support the shear blade carrier as it is lowered from the machine (Fig. 15G).

9. Remove the 4 x M12 hex bolts (Fig. 15H) securing the cylinder on the left-hand side.
10. Remove the 4 x M12 hex bolts (Fig. 15I) securing the cylinder on the right-hand side. Carefully lower the cylinder down and away from the machine (Fig. 15J)
11. To insert a cylinder, repeat steps 1-10 in reverse, using instructions in "6.2.1. Cylinder and Drive Belt Replacement/Tensioning" p.39 to aid in reapplying the belt and tensioning.

Fig.15. Removing and Inserting a Cylinder

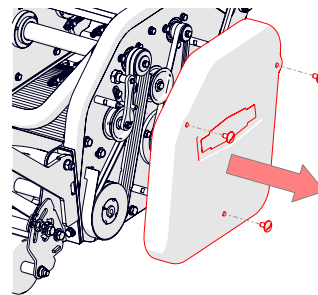

Fig. 15A - Remove 3 x outer screws and cover.

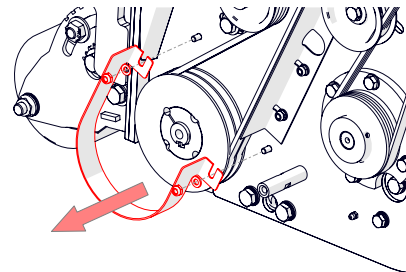

Fig. 15B - Remove the belt guide.

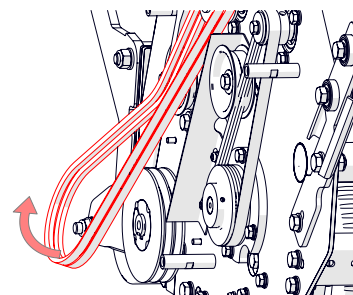

Fig. 15C - Remove and replace the belt.

6. Maintenance and Service

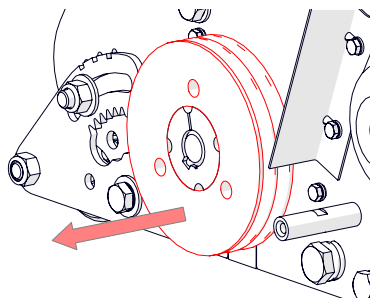

Fig. 15D - Remove the pulley.

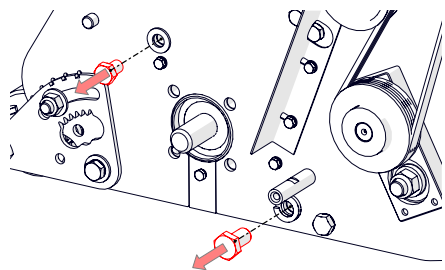

Fig. 15E - Remove LH shear blade hex screws.

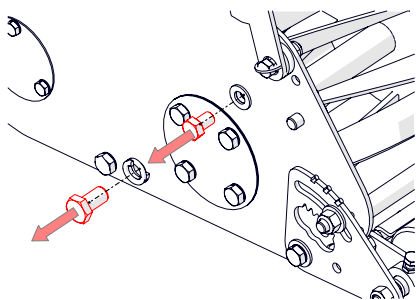

Fig. 15F - Remove RH shear blade hex screws.

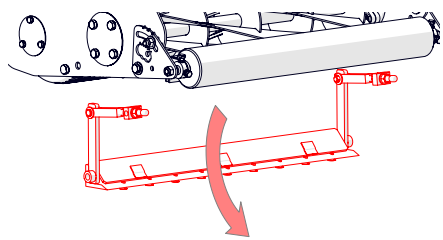

Fig. 15G - Remove shear blade from the machine.

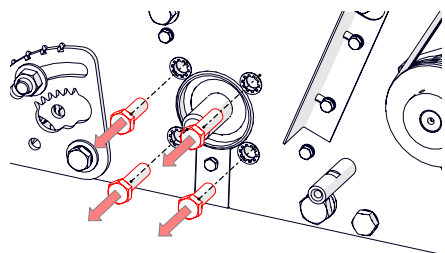

Fig. 15H - Remove cylinder securing bolts from LH side.

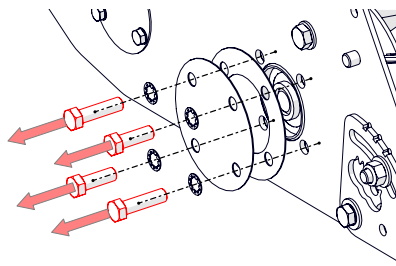

Fig. 15I - Remove cylinder securing bolts from RH side.

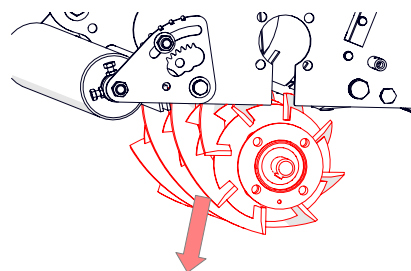

Fig. 15J - Remove cylinder from the machine.

6. Maintenance and Service

6.2.4. Backlapping

Cutting blades will become blunt over time, producing an inferior quality of cut. Backlapping is the method of sharpening both the cylinder and shear blade simultaneously using a grinding compound while manually running the drive in reverse. This maintains a sharp edge on the blades to prolong their life, however it is not a substitute for a true grind. Do **not** backlap on damage blades or those beyond repair.

Grinding paste is required to achieve the sharpening of the blades. Three grit types are commonly available (80/120/220 grit) - the type chosen should be based on blade number, wear and expected use.



WARNING - BACKLAPPING

- **Always** wear suitable PPE, including eye protection and gloves.
- **Always** use a long handled brush. This minimises risk of close contact with the spinning cylinder.
- Backlap in a suitable area where the paste can be washed away afterwards. The paste can splatter so ensure a distance is maintained around the machine.

Tools required:

- Long handled brush
 - Back lapping paste
 - Backlap drive adaptor (p/n 229571)
 - Speed brace /drill (1/2" drive)
 - Slotted screwdriver
 - 10 mm spanner
1. Follow steps 1-6 in "**6.2.3. Removing a Cylinder**" p.44.
 2. Apply a small amount of grinding paste along the whole length of each blade using a long handled brush (Fig. 16A).
 3. Insert the backlap drive adaptor into the cylinder pulley.

4. Using a suitable brace or drill, rotate the cylinder clockwise causing a grinding action with the shear blade (Fig. 16B). This should be continued until a sharp lip is achieved on the leading edge of each cylinder blade. This may take a few minutes - stop periodically to check the edge and reapply paste as necessary.

Note: rotating the cylinder clockwise is opposite to the normal operation of the machine. This may cause the drive coupling to become unscrewed. If this occurs, chock the cylinder with a piece of wood or similar, and tighten the drive coupling [Left hand thread].

5. When backlapping is complete, all grinding paste must be cleaned off the cylinder. This can be achieved with a low powered hose or a sponge and bucket of water. Failure to clean thoroughly will result in accelerated wear while cutting.
6. Return the cylinder to the machine. The machine will now need the shear blade adjusting to account for the change to the cylinder, "**5.2.3. Shear Blade Adjustment**" p.24.

Fig.16. Backlapping

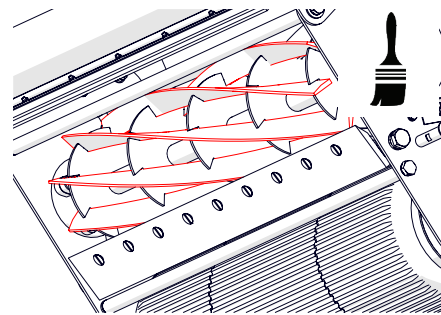

Fig. 16A - Apply paste to the blades

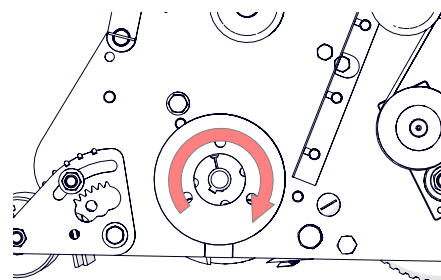

Fig. 16B - Rotate the cylinder clockwise using the adapter.

6. Maintenance and Service

6.2.5. Grinding Cutting Blades

Grinding, as with backlapping, restores the sharp edge of the blades, allowing for a clean, precise cut. Grinding is highly recommended to maintain optimal performance and extend the life of the cutting cylinder. However unlike backlapping, this method creates an 'as new' sharp edge, rather than a temporary honed one.

Grinding is recommended when paper does not cut cleanly from the shear blade test (see "5.2.3. Shear Blade Adjustment" p.24), or when backlapping does not achieve the sharp edge required (usually caused by the edge being rounded too far beyond the capabilities of backlapping). Grinding can also help restore the cylindrical shape of the cylinder, which without, would be seen in poor grass cutting quality and streak marks.

Two grinding methods are performed on our cutting cylinders - spin and relief. As standard, all Dennis cutting cylinders are spun ground, with those of eight blades or more having an additional relief grind. Relief grinding is the process of removing material from the back of each cylinder blade to create a slight angle (i.e. the 'relief').

This relief angle produces a number of benefits:

- Improved cutting quality.
- Increased efficiency: Relief ground cylinders have been shown to reduce the power required to achieve a cut, thereby reducing fuel consumption. This is achieved from less friction between the cylinder and shear blade.
- Less wear between the cylinder and shear blade resulting in:
 - i. Longer blade life for both cylinder and shear blades.
 - ii. Less cylinder/shear blade adjustments.
 - iii. Less backlapping maintenance.
- Longer service life of adjacent moving parts, such as bearings and gears.

Factory standard relief grind is 50% land area at 30 degrees (see Fig. 17). It is recommended to grind to these values.

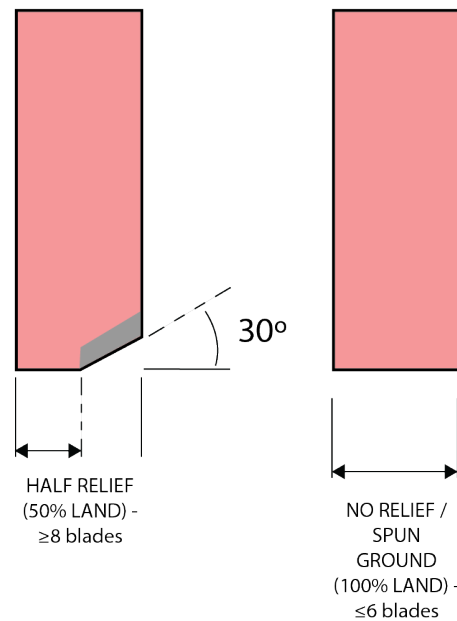

Fig.17. Recommended cylinder grind angle

Shear blades also need to be ground, ideally at the same time as the cutting cylinder. It is important to include a relief grind as this helps present the grass at the correct height for cutting. Without this, using a flat or positive front angle can lead to inconsistent cutting heights and an uneven grass surface (see Fig. 19).

Factory standard is a front angle of -10° and top angle of -8°, as shown in Fig. 18.

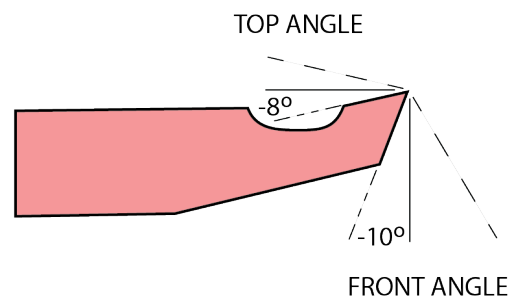

Fig.18. Recommended shear blade grind angle

6. Maintenance and Service

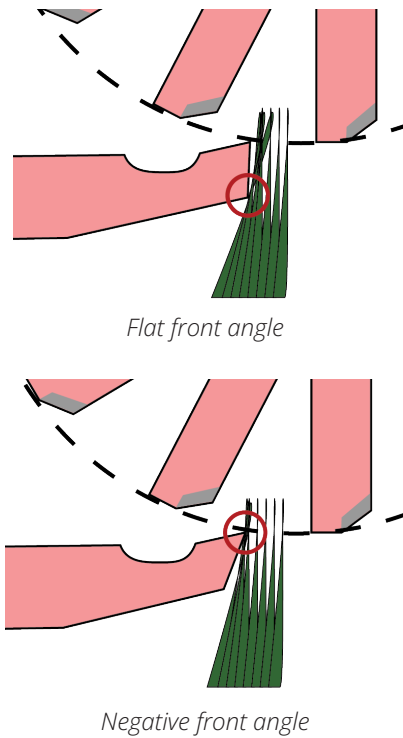

Fig.19. Illustration of two different shear blade angles and their grass contact point

For any method of grind, you must use a professional grinding service or dedicated grinding machine. Fail to do this may result in a far inferior cut and increased risk of injury.

6.2.6. Checking/Tensioning Parking Brake

Over time, wear and tear may reduce the parking brake effectiveness. If the following occurs when the parking brake is on then adjustment may be required:

- The machine moves under its own weight on a slope, or
- Can be easily pushed with minimal resistance,

Alternatively the brake may have been adjusted too tight and cannot be engaged.

Tools required:

- Spanners: 10 mm and 13 mm
1. Turn the machine **off** and allow the engine to cool.
 2. Chock the front and rear rollers.
 3. Remove the transmission guard by loosening the 4 x M8 bolts [13 mm spanner] and lifting the guard upwards and away from the machine.
 4. Inspect the brake pads. If the wear indicator grooves are visible then replacement is not required. If the wear indicators are not visible, then replace with new before continuing to adjust tension.
 5. *Optional* - Remove the brake caliper [10 mm spanner] for easier access to park brake cable adjustment.
 6. Loosen the nut of the brake cable [10 mm spanner] and adjust the brake cable accordingly.
 7. Replace the brake caliper (if removed) and tighten.
 8. Operate the parking brake lever - it must engage fully and the brake hold the weight of the machine.

6. Maintenance and Service

6.2.7. Changing Rear Roller Oil

The rear roller is split into three sections incorporating a differential gear system. This is lubricated with oil which requires replacement annually or every 1200hrs.

To replace the oil in the rear roller:

Tools required:

- Lifting jack, raised platform or another method to raise the machine
 - Wooden chocks
 - 8 mm hex socket
 - Oil tray (volume >0.8 L)
 - Oil absorbent pads
 - Oil (grade EP90) - 0.5 L (G26), 0.6 L (G30), 0.7 L (G34)
 - Oil funnel and tube, or similar
-
1. Turn the machine **off** and allow the engine to cool.
 2. Chock the front rollers. Lift the rear of the machine enough to gain clearance for 8 mm hex socket and oil tray.
 3. Place oil absorbent pads down under the roller along with an oil tray.
 4. Rotate the central roller until the drain hole is pointing downwards (Fig. 20A & Fig. 20B).
 5. Remove the tapered plug [8 mm hex socket] and let the oil drain.
 6. Once fully drained, rotate the roller until the drain hole is pointing rearwards and above horizontal.
 7. Fill the roller with the correct grade and quantity of oil using the funnel/tube or similar.
 8. Insert the tapered plug. Remove the oil absorbent pads and trays and dispose of in a responsible manner.
 9. Lower the machine. The machine is now ready for use.

Fig.20. Rear roller oil

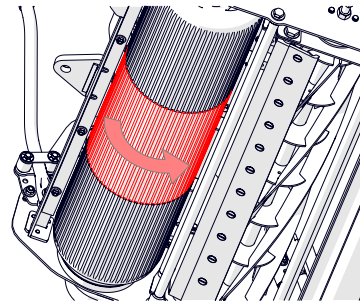

Fig. 20A - Rotate central roller.

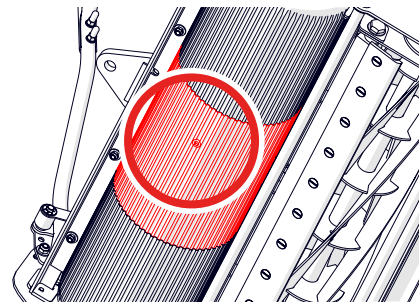
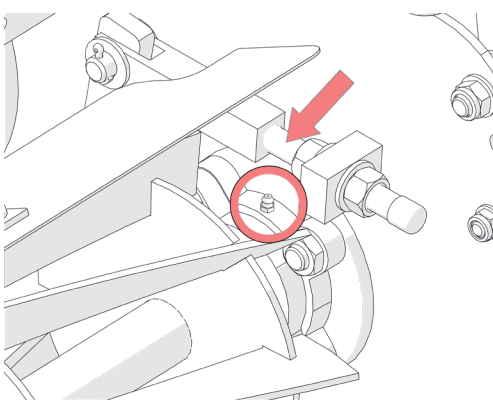
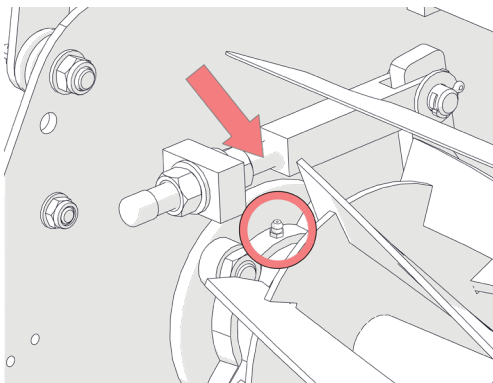

Fig. 20B - Roller drain hole pointing downwards.

6. Maintenance and Service

6.2.8. Lubrication

Grease the following locations at the intervals stated. We recommend to use a grease gun with a multipurpose lithium EP2 grease.

Location	Frequency (whichever is first)
<p>Left hand side:</p> <ul style="list-style-type: none"> • Cylinder bearing • Shear blade adjuster rod 	<p>One pump weekly or every 25hrs</p>
<p>Right hand side:</p> <ul style="list-style-type: none"> • Cylinder bearing • Shear blade adjuster rod 	

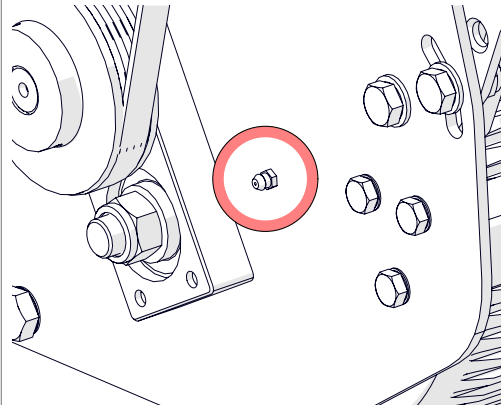
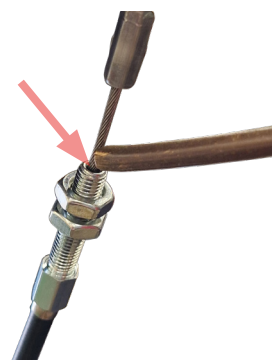
Location	Frequency (whichever is first)
<p>Rear roller internal spur gear (found underneath belt guard)</p> 	<p>One pump weekly or every 25hrs</p>
<p>Control cables (x4). Access by removing the cover of the control components. Loosen the nuts securing the cable to the chassis and unhook the spring. Allow the oil to flow down the protective cables and operate the cable a few times before reattaching.</p> 	<p>Few drops of oil monthly or every 100hrs</p>
<p>Control levers (x4). Access by removing the cover of the control components. Apply copper grease to metal-on-metal components of the control levers, taking care not to make contact with the micro switches.</p>	<p>Small amount of copper grease monthly or every 100hrs</p>
<p>Rear roller oil - see "6.2.7. Changing Rear Roller Oil" p.49</p>	<p>Replace annually or every 1200hrs</p>

6. Maintenance and Service

6.2.9. Guide Peg Adjustment

The guide peg is designed to quicken disengagement of the belt when the cutting tensioner pulley is in the *disengaged* position. It achieves this by providing a contact point for the belt and creating a small uplift, away from the top drive pulley. Without the peg in the correct position, the belt (and therefore cylinder) will continue to run for a longer duration than necessary.

Tools required:

- Flat-headed screwdriver
 - 13 mm spanner
1. Turn the machine **off**. Engage the parking brake and cutting lever.
 2. Remove the belt guard [flat-headed screwdriver].
 3. Loosen the guide peg hex screw [13 mm spanner].
 4. Slide/rotate the guide plate until the guide peg is very close to the belt (but *not* touching) and as high up as possible (Fig.21A & 21B). It must not make contact with any part of the cutting pulley or its arm.
 5. Tighten the guide peg hex screw [13 mm spanner].

Fig.21. Guide peg adjustment

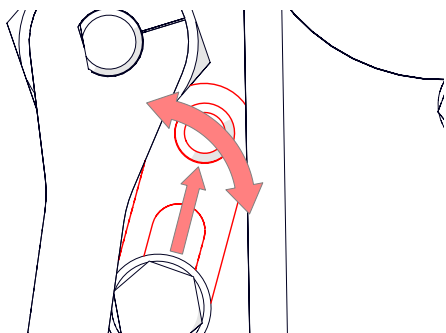

Fig.21A - Rotate and slide the guide to maximum

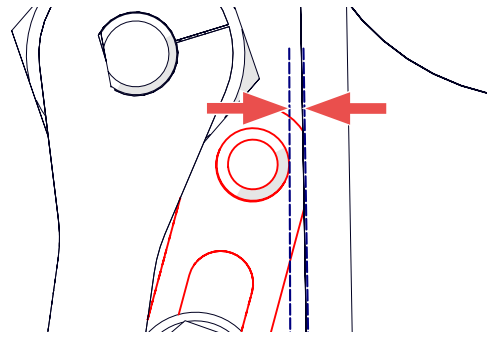

Fig.21B - Keep a very small gap between the peg and belt when pulley in the engaged

6.3. Cleaning



CAUTION - WATER DAMAGE

Do not use a pressurised hose to clean your machine. Doing so may cause water ingress, damage and invalidate your warranty.



WARNING - SAFETY

Never place your hands inside the cylinder area without firstly turning the machine **off**. We recommend to wear safety gloves and to use a long handled brush for cleaning.

Use a soft brush to remove as much grass and debris as possible. If further cleaning is required:

- **Chassis** - Remove the grass box and tilt the machine backwards so it rests on the handlebars. Using a low pressure hose, wash all of the grass from under the machine and around the cylinder. Take extra care around the bearings, avoiding direct contact with the hose. Dry thoroughly after use.
- **Engine** - Allow to cool for at least 30mins before cleaning. Do **not** use a hose or pressurised hose to clean as this can cause damage. Use a damp cloth and brush.
- **Grass box** - Use a low pressure hose to rinse the inside of the box. Leave upside down to drip-dry before returning back to the machine.

6. Maintenance and Service

6.4. Handling and Transport



WARNING - LIFTING

Do *not* lift the machine as it does *not* have designated lifting points. Lifting the machine may result in injury, damage to the machine, or both.

- Use a ramp to aid the machine onto a vehicle. For the technical specification of the machine, please refer to "**4.1. Technical Specifications**" p.13. The weight can also be found on the serial number plate.
- Anchor the machine to the floor/pallet using suitably rated tie-down straps. Anchor around the front and rear tie-bars (high-lighted red in Fig. 21).
- Transport with fuel emptied - see note.
- Turn the machine **off** during transport (both from the engine and control components on the handlebar). Ensure the engine is fully cool before transporting or handling.



NOTE - SHIPPING THE ENGINE

Legislation for transporting and shipping a machine with an engine vary country to country. In most cases the fuel tank and carburettor must be completely emptied before transport. Additional requirements may include certification, declarations and packaging requirements. Always follow the requirements for your country and destination.

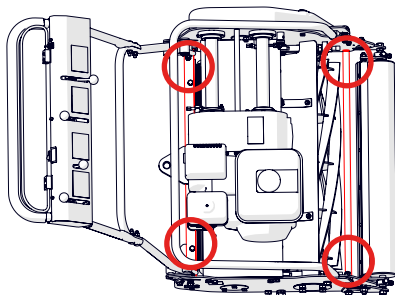

Fig.22. Anchor points for transport.

6.5. Storage



CAUTION - INCORRECT STORAGE

- Failure to store the machine correctly will cause machine degradation and reduce its operating life.
- The points below exclude specific requirements for the engine and fuel. Refer to the supplied OEM 'Owner's Manual' for these storage requirements.

Follow the points below for the correct storage of your machine. For the storage of petrol, refer to the regulations of your country:

- Store in a location away from direct sunlight, flames, heat sources and areas with high shock/vibrations.
- Store in a location maintaining a consistent temperature of -20°C to +35°C. Avoid high fluctuations.
- Store in a location that is dry, preferably with a relative humidity between 30–70% RH.
- Thoroughly clean and dry the machine prior to storage.
- Apply a small amount of grease to the cutting edge of the cylinder and shear blade. Use a small brush to achieve this.
- Store on a flat surface with the parking brake **on**. Chock the front and rear of the machine.
- Cover the machine to protect from damage and dust.

6. Maintenance and Service

6.6. Disposal

6.6.1. Machine Disposal



NOTE - DISPOSAL NOTES

Check and comply with all environmental regulations and local disposal guidelines.

Dispose of the product in an environmentally friendly manner. The machine is predominately made up from metal waste - these can be suitably recycled at a local refuse collection site.



CAUTION - INJURY

Take care when removing components from the machine. If done incorrectly it may cause injury to yourself or damage to the surrounding environment. Wear suitable PPE and dismantle in an appropriate area.

1. Take the machine to a suitable area to allow for the removal of parts. Take into account access to the machine, tool availability, oil and other contaminants.
2. Wear suitable PPE. This must include safety glasses and gloves as a minimum.
3. Place oil absorbent pads under and around the machine.
4. Safely drain all fluids from the machine and engine using a siphon pump or similar, including oil and fuel. Use appropriate containers to collect these fluids and clearly label with their contents.
5. Clean the machine thoroughly.
6. Detach any removable parts, such as the handlebar, bodywork, rollers and cylinder.
7. Separate recyclable parts like metal, plastic and electronic. Recycle at a recycling facility.
8. Dispose of non-recyclable components in accordance with local waste disposal regulations.
9. Document the decommissioning process for record keeping.

6.6.2. Hazardous Materials

The engine contains petrol and oil which are classed as hazardous waste. Dispose of at a suitable recycling facility.

Other components to note include lubricating grease and roller bearing oil which may contaminate waste during recycling. The oil and grease should be removed prior to disposal with a suitable solvent or degreaser such as brake cleaner /denatured alcohol and wipes.

6.7. Troubleshooting & FAQ



WARNING - SAFETY

- You **must** turn the machine **off** before actioning any cause. Failure to do so may cause major injury.
- Always wear suitable PPE for the job at hand.

The most common troubleshooting issues are shown in Appendix C. If your fault is not shown or you are still experiencing problems, please contact Dennis directly.

6.8. Warranty Policy

For full warranty terms and conditions, please contact your Dealer or refer to the warranty policy supplied separately.

Appendix

Appendix A. Optional Items and Attachments

A1. Weile (Grooved) Roller

This option replaces the standard smooth front roller with a weile (grooved) roller. A weile roller has less surface area so the machine sits lower in the turf, allowing for the leaf blades to stand more upright in the grooves prior to being cut. This generally achieves a more consistent height and quality of cut. The grooves also help maintain better traction, so more suited to thicker turf, uneven ground and slopes.

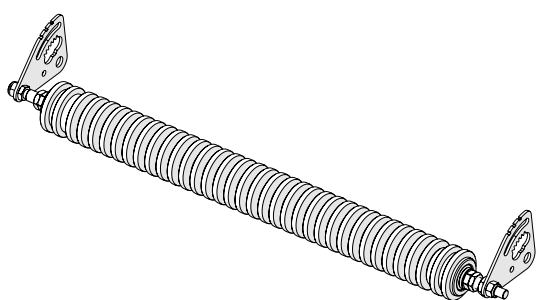

Fig.23. Weile Roller

However, a smooth roller distributes the machine weight more evenly provides and is therefore less aggressive on the turf. Use a smooth roller on well maintained level turf, or if your turf is stressed, recently aerated or in soft ground conditions.

To remove the roller:

Tools required:

- Spanners: 17 mm and 19 mm

To remove the roller:

1. Turn the machine **off**.
2. Remove the grassbox and fold the carry frame up.
3. Remove the three fixings from the roller quadrant, as illustrated in Fig. 24A [19 mm spanner, 17 mm spanner].
4. Loosen (do not remove) the M12 bolt

securing the tie-bar [19 mm spanner] (Fig. 24B).

5. The roller quadrant will now be able to move slightly to make space to remove the front roller (Fig. 24C).
6. Replace the roller as desired and move the roller quadrant back into position.
7. Tighten the M12 bolt securing the tie-bar.
8. Reattach and tighten the three fixings from the roller quadrant

Fig.24. Front roller removal

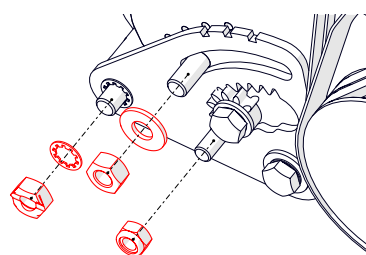

Fig. 24A - Remove the three fixings as illustrated.

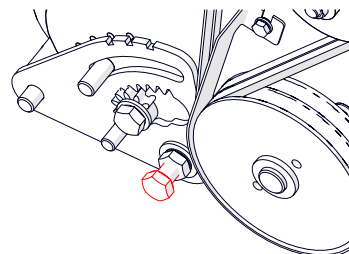

Fig. 24B - Loosen the tie-bar bolt.

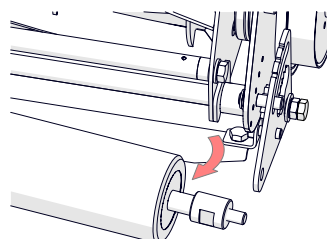

Fig. 24C - Remove the roller.

Appendix

A2. Suspension trailer seat

Both the standard and self-steer trailer seats are designed to reduce operator fatigue during extended periods of use. They also add an additional level of striping along with the rear roller of the machine. Both seats have built-in suspension and adjustments for greater comfort.

The self-steer trailer seat has an additional pivot underneath the seat and a cross brace from the machine rear tie bar to the trailer seat rear roller. This allows for greater manoeuvrability, with the trailer seat following the turns of the machine more closely. On delivery, this trailer seat will have a transport bracket located above the roller - remove this before proceeding with its use.

Both seats are supplied with a towball bracket that requires mounted to the rear tie bar of the machine.

To attach the trailer seat:

Tools required:

- Spanners: 19 mm (x2)
1. Turn the machine **off**.
 2. Position up the towball bracket to the rear tie-bar/scraper (Fig. 25A).
 3. Insert two M12 bolts from underneath and secure with nuts on the top [19 mm spanner x 2] (Fig. 25B).
 4. Couple the trailer seat to the towball, ensuring the cross-brace is also attached, secured with the spring clip (Fig. 28C).
 5. Adjust the handlebar height to a comfortable position prior to using. Controls remain the same as with walking, but a slightly different technique may be required, particularly when turning. Test steering and ensure you are comfortable before cutting.

Fig.25. Trailer Seat Attachment

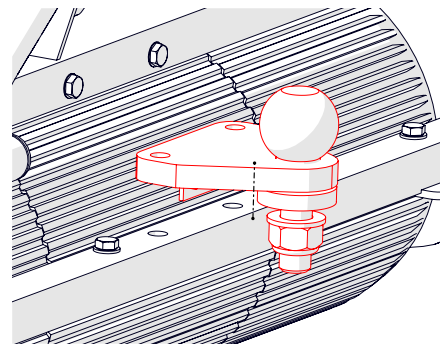

Fig. 25A - Position the towball bracket.

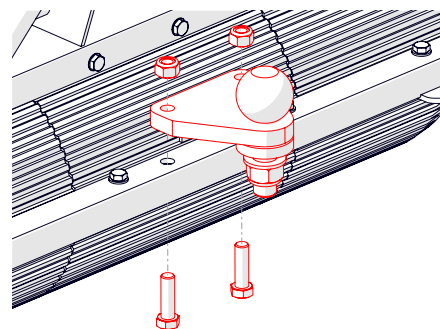

Fig. 25B - Insert the bolts from underneath and tighten.

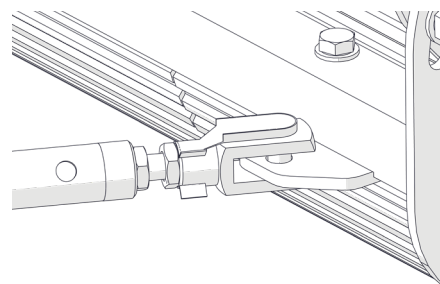

Fig. 25C - Secure cross brace with the spring clip.

Appendix

Appendix B. Service Kit

The service kits below are available to be purchased to aid in the servicing of the machine:

Service area of machine	Kit number	Item description	Item part number	Qty
(SK02) - Rear Roller	SK02009	Roller Bearing 6205-2RS	062662	2
		BEARING 6204-2RS 3	J20052	4
		Rear Roller Drive Belt - 4PK 698	228012	1
		PIN SPIROL M5 X 45	228053	1
		TENSIONER PULLEY	229038	1
		HEX SET SCREW 3/8" UNF X 2 1/2"	SP01068	1
		NUT 3/8" UNF NYLOC (T)	SP02018	1
		GREASE NIPPLE 1/4" UNF	J20064	1
		GRUB SCREW M8 X 8	J20467	1
		GRUB SCREW 3/8" BSPT	171702	1
		GEAR OIL EP90 (860 qty)	OIL	0.7l
(SK04) - Handles	SK04002	Throttle Cable	SP12002	1
		GROMMET PV270A	260138	1
		Cutter Drive Clutch Cable	229378	1
		CABLE RETURN SPRING	229422	1
		Roller Drive Clutch Cable	229596	1
		CABLE RETURN SPRING (NOT CYLINDER)	229421	1
		Brake Cable	229597	1
(SK05) - Drive/Power	SK05009	Cylinder Drive Belt - V Z-997	228030	2
		Rear Roller Drive Belt - 4PK 698	228012	1
		Transmission Drive Belt - V X10-665 LP	228007	1
(SK06) - Cutter	SK06010	Cylinder Drive Belt - V Z-997	228030	2
		Drive Gasket	229335	1
		Roller Bearing 6205-2RS	062662	2
		COUPLING ELEMENT	228103	1
		TENSIONER PULLEY	229038	2
		HEX SET SCREW 3/8" UNF X 1 1/2"	SP01071	1
		NUT 3/8" UNF LOCK (THIN)	SP02033	1
		CSK CAP HEAD M8 X 16	SP01077	4
		GRUB SCREW M8 X 8	J20467	1
		BEARING 6204-2RS 3	J20052	2

Appendix C. FAQ and Troubleshooting

Issue	Possible Cause	Action
Engine won't start	[See OEM 'Owner's Manual']	[See OEM 'Owner's Manual']
Engine lacks power	[See OEM 'Owner's Manual']	[See OEM 'Owner's Manual']
Engine starts but stalls	<ol style="list-style-type: none"> 1. Choke left in the 'closed' position after warm-up. 2. Dirty carburettor. 3. Blocked fuel line or filter. 4. Low oil level triggering shutoff. 	<ol style="list-style-type: none"> 1. Move choke to the 'open' position. 2. Clean carburettor. 3. Inspect and clean fuel system. 4. Check oil level.
Engine runs rough or misfires	<ol style="list-style-type: none"> 1. Dirty or incorrect spark plug gap. 2. Contaminated fuel. 3. Air leak in intake system. 4. Clogged air filter. 5. Choke left in the 'closed' position after warm-up. 	<ol style="list-style-type: none"> 1. Clean or replace spark plug, check gap. 2. Drain and replace fuel. 3. Inspect intake gaskets and connections. 4. Clean or replace air filter. 5. Move choke to the 'open' position.
Grass does not cut.	<ol style="list-style-type: none"> 1. Cutting height is higher than grass length. 2. Gap between cylinder and shear blade is too much. 3. Cylinder and shear blades not sharp. 	<ol style="list-style-type: none"> 1. Adjust cutting height so it is below current grass height. 2. Adjust the shear blade - see "5.2.3. Shear Blade Adjustment" p.24. 3. See "6.2.4. Backlapping" p.46. If backlapping not sufficient, remove and re-sharpen using professional grinder/services.
Cylinder keeps spinning with the lever in the 'disengaged' position.	<ol style="list-style-type: none"> 1. Clutch is stuck or set too taut and cannot disengage with the cylinder belt. 2. Guards surrounding the belt are set too close and providing a form of 'clutch'. 3. Guide peg is not set correctly and not providing the extra support for disengagement. 	<ol style="list-style-type: none"> 1. Re-tension cylinder belt. See "6.2.1. Cylinder and Drive Belt Replacement/Tensioning" p.39. 2. In the disengaged state, the belt should be static despite the upper pulley still spinning. Open the belt guard and readjust the guards away from the belt so they do not make contact. See "6.2.1. Cylinder and Drive Belt Replacement/Tensioning" p.39. 3. In the disengaged state, the belt should be making light contact with the guide peg. See "6.2.9. Guide Peg Adjustment" p.51.

Appendix

Issue	Possible Cause	Action
Cylinder does not spin with the lever in the 'engaged' position.	<ol style="list-style-type: none"> 1. Clutch is set too loose and cannot engage with drive belt. 2. Guide peg making contact with the tensioner pulley stopping it fully engage. 3. Faulty OPC. 	<ol style="list-style-type: none"> 1. Re-tension cylinder belt. See "6.2.1. Cylinder and Drive Belt Replacement/Tensioning" p.39. 2. Engage the cylinder lever and check the tensioner pulley does not contact the guide peg. If it does, readjust the guide peg accordingly. 3. Inspect the micro-switch of OPC, replace if necessary.
OPC will not disengage when released	<ol style="list-style-type: none"> 1. Check the OPC operates freely and no damage to pivot block. 2. Parking brake microswitch faulty. 	<ol style="list-style-type: none"> 1. Service/replace OPC if faulty. 2. Service/replace OPC if faulty.

Page intentionally left blank.



Email
sales@howardsongroup.com

UK & International
Tel: +44 (0) 1332 824777

Head Office
Ashbourne Road, Kirk Langley,
Derby, DE6 4NJ, UK

Due to a policy of continual development Howardson Group Ltd reserves the right to change specification without prior notification.
All goods sold subject to the company's terms and conditions of sale, copies available on request.

E&EO