

# DENNIS

## PRO 34R INSTRUCTION MANUAL

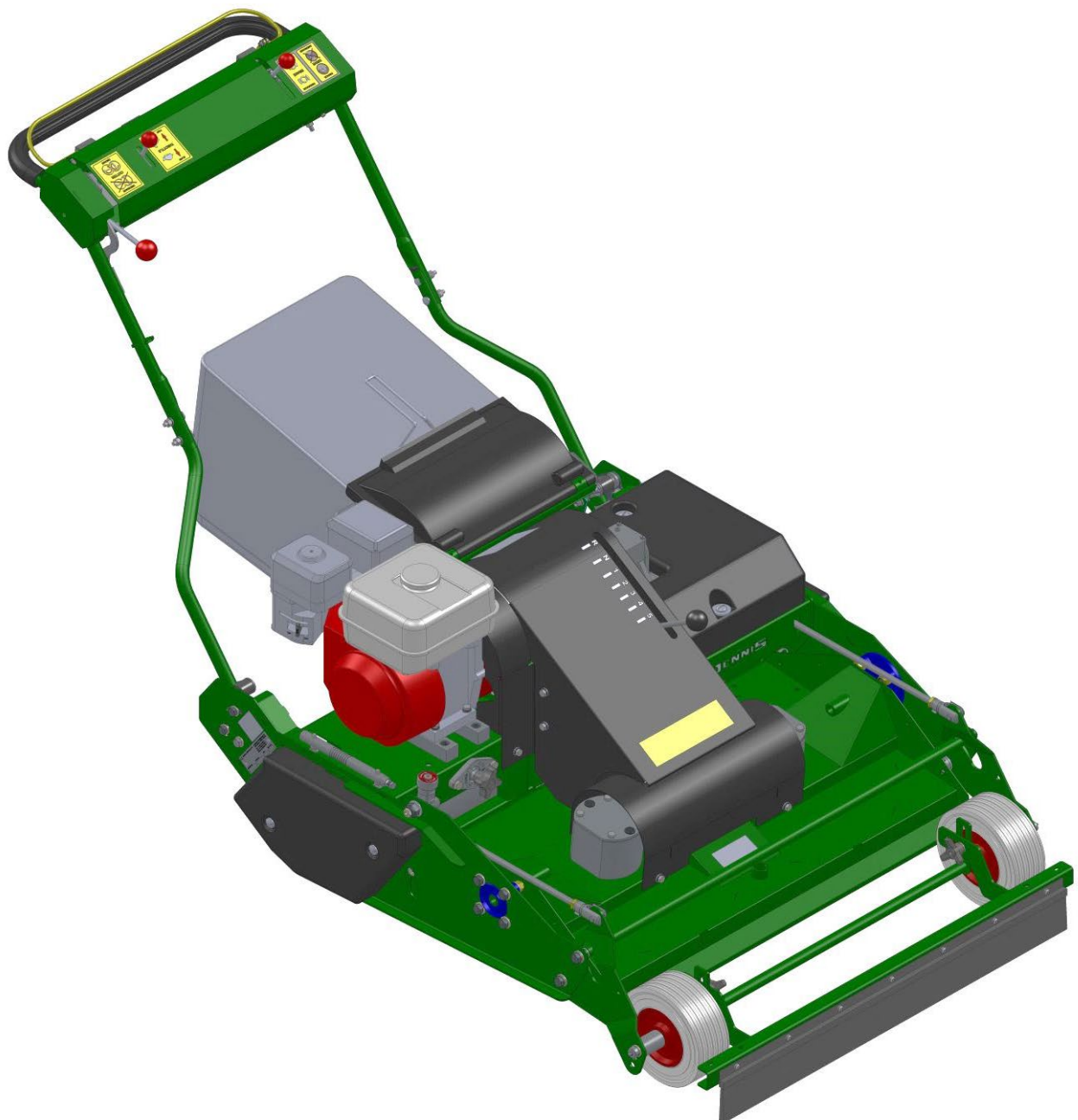

# Product Application Matrix

Applications	FT Range	Razor Ultra	Razor	Simplex Range	SuperSi x Range	G660 G760 G860	G26D G30D G34D	Premier Range	Verticut TT	S500 PLUS	Bray Hand Tools	PRO 34R
Bowls, Croquet, Tennis	●	●	●		Croquet and Tennis only	Croquet and Tennis only	Croquet and Tennis only	Tennis Only	●	●	●	
Football, Hockey, Rugby						●	●	●		●		●
Cricket – Wicket	●	●	●						●	●	●	
Cricket – Square	●	●	●	●	●	●	●	●	●	●	●	●
Cricket – Outfield						●	●	●				
Golf – Tees	●	●	●	●	●	●	●		●	●	●	●
Golf – Greens	●	●	●						●	●	●	
Ornamental/Lawns	●			●	●	●	●	●	●	●	●	●
Local Authority/Contractors	●	●	●	●	●	●	●	●	●	●	●	●



**NOTE:-**

THIS INFORMATION IS INTENDED FOR GUIDANCE PURPOSES ONLY. WE RECOMMEND THAT YOU DISCUSS YOUR SPECIFIC REQUIREMENTS WITH OUR HEAD OFFICE, SALES MANAGERS OR YOUR LOCAL DENNIS DEALER

**EU DECLARATION OF CONFORMITY**

**PRO 34R Rotary Mower powered by Honda GX Petrol Engine**

**Manufacturer:-**

- Howardson Ltd, Howardson Works, Kirk Langley, Derby, DE6 4NJ. UK

**Owner of Technical Document:-**

- Mr I.D. Howard, Howardson Ltd, Howardson Works Kirk Langley, Derby, DE6 4NJ, UK

**Notified Body:-**

- Vincotte, NB0026, Jan Olieslagerslaan 35, B-1800 Vilvoorde, Belgium

I the undersigned declare that this machine:-

Model	Cutting Width	Power (Honda)	Measured Sound Power Level	Guaranteed Sound Power Level	Serial Number
PRO 34R	860mm	GX200 (4.1kW @ 3600 RPM)	100dB Lwa	100dB Lwa	See product ID Range

Tested at:-

- Howardson Works

Complies with the applicable requirements of:-

- Machine Directive 2006/42/EC
- Noise Directive 2000/14/EC (Annex VI Procedure 1)

Managing Director



Ian Howard



Ashbourne Road, Kirk Langley, Derbyshire, DE6 4NJ, England

Tel: +44 (0) 1332 824 777

A division of Howardson Ltd – a proudly British company

[www.dennisuk.com](http://www.dennisuk.com) [www.sisis.com](http://www.sisis.com)



**NOTE:-**

*MAKE A NOTE OF THE SERIAL NUMBER OF YOUR MACHINE AND ALWAYS QUOTE IT IN ANY COMMUNICATION WITH PERSONNEL AT DENNIS.*

**MACHINE SERIAL NUMBER**

**ENGINE SERIAL NUMBER**

## INTRODUCTION

The reliability and quality of performance of the **DENNIS PRO 34R** depends upon some simple care maintenance carried out regularly. This manual has been prepared to allow the user to carry out all such work.

It is advisable to read the instructions carefully. Proper care and attention will enable the machine to give a continuous, satisfactory, and reliable service. Failure to carry out regular lubrication and maintenance as outlined in this manual may render any guarantee or warranty invalid.

In the case of any difficulty, or if further information or advice is required, our Service Department is always at your call. In the interests of speed and accuracy of information please quote the serial numbers of the machine and engine when making enquiries.

For the machine, this is to be found on a plate attached to the side frame. The engine number is stamped on either the crank case or the gear casing facing towards the front of the machine. We suggest you write the numbers on the front page of this book.

	Page
Product Application Matrix.....	1
Declaration of Conformity.....	2
Serial Numbers.....	3
Introduction.....	3
Technical Data.....	4
Machine Description.....	5
Important Safety Instructions.....	6
Controls.....	7
Operating Instructions.....	8 - 9
Adjustments.....	10 - 11
Routine Maintenance and Lubrication.....	12
General Lubrication.....	13
Storage.....	13
Parts Listings.....	P0 – P12

## TECHNICAL DATA

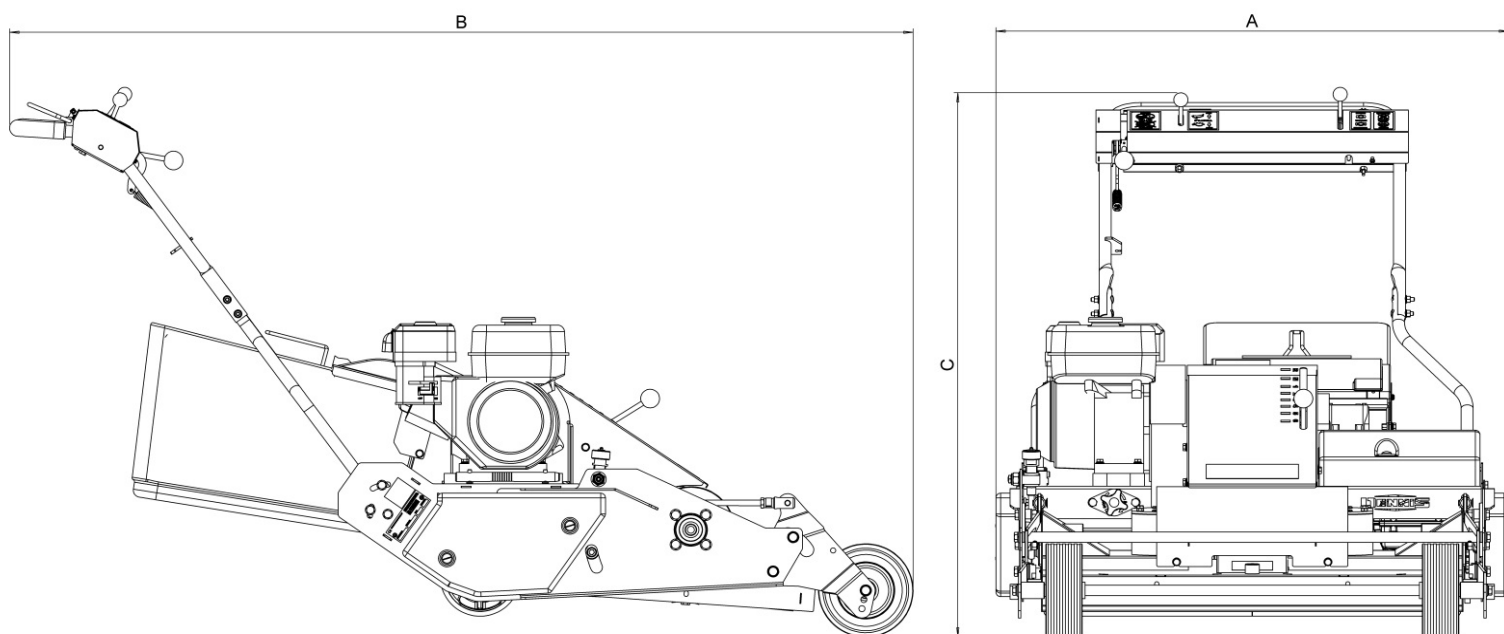

MODEL	PRO 34R
A – WIDTH (cm)	108.4
B – LENGTH (cm)	189.5
C – Height (cm)	108
Weight (Kg)	190
Cutting Width (cm)	86
Number of Rotary Blades	2
Height of Cut (mm)	15 - 50
Engine	Honda GX200
Guaranteed Sound Power Level	100 dB Lwa
Vibration (m/sec <sup>2</sup> )	4
MAX RPM	2600 min-1

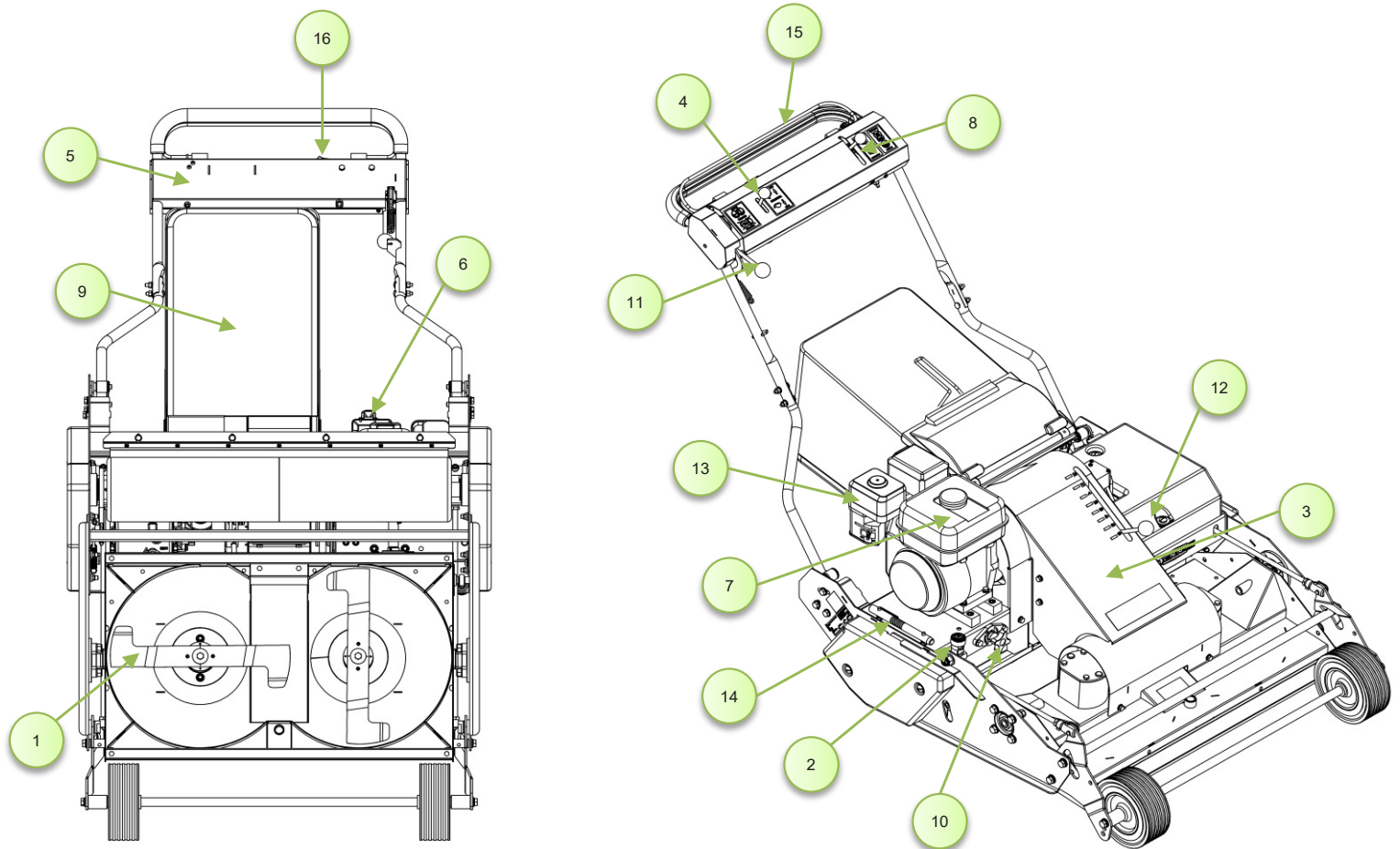

NUMBER	PART	NUMBER	PART
1	Rotary Blades	9	Grass Box
2	Tilt Adjuster	10	Cutting Height Adjustment
3	Belt Guard	11	Blade Control
4	Throttle Control Lever	12	Gear Control Lever
5	Operating Console	13	Air Filter
6	Exhaust	14	Height Gauge
7	Fuel Tank	15	Deadman's Handle
8	Driving/Brake Control Lever	16	On/Off Switch

# Important Safety Instructions

In order to operate the machine safely please follow these Health and Safety guidelines

Where possible, steps have been taken during the design of this machinery to reduce noise emission\*\*\*. To take full advantage of this, it is essential that the machine only be used when setup correctly and is fully serviceable (see instructions).

\*\*\*Note: Mandatory Ear Protection required when Sound Pressure Levels reach 85 dB LPA.

## TRAINING



**CAUTION** – READ THE INSTRUCTIONS CONTAINED IN THIS MANUAL WITH CARE. IF YOU ARE IN ANY DOUBT PLEASE ASK YOUR EMPLOYER OR CONTACT US DIRECT AT **DENNIS**

- Be familiar with the controls and the proper use of the equipment.
- Never allow children or people unfamiliar with these instructions to use the mower. Local regulations or insurance may restrict the age of the operator.
- Never mow while people, especially children, or pets are near by.
- Keep in mind that the operator or user is responsible for accidents or hazards occurring to the other people or their property.

## PREPARATION

- While mowing always wear substantial footwear and long trousers. Do not operate the mower barefoot or in open sandals.
- Thoroughly inspect where the equipment is to be used and remove all stones, sticks, wire, bones and other foreign objects.



**WARNING** – PETROL IS HIGHLY FLAMMABLE AND WILL DAMAGE GRASS IF SPILT.

- A. Store fuel in containers specifically designed for this purpose.
  - B. Refuel out doors and do not refuel whilst smoking.
  - C. Add fuel before starting the engine. Never remove the cap of the fuel tank or petrol while the engine is running or when the engine is hot.
  - D. If petrol is spilt do not attempt to start the engine but move the machine away from the area of spill and avoid creating and sources of ignition until the vapours have dissipated.
- Replace damaged or faulty silencers.
  - Before using the machine always inspect the safety devices including the cut off switch and the blades for excessive wear or damage. Replace if necessary.

## OPERATION

- Do not operate the machine when tired, ill, under the influence of drugs or alcohol.
- Do not operate the engine in a confined space where dangerous CARBON MONOXIDE fumes can collect.
- Mow only in daylight or good artificial light.
- Do not operate the machine when there is risk of lightening.
- Avoid operating the machine in wet grass where feasible.
- Always be sure of your footing on slopes.
- Do not mow excessively steep slopes.
- Walk across the face of slopes, never up and down.
- Exercise extreme care on slopes when changing direction.
- Walk. Never run.
- Use extreme caution when reversing or pulling the machine towards you.
- Stop the blades if the mower has to be tilted for transportation when crossing surfaces other than grass and when transporting the mower to and from the area to be mown.
- Never operate the mower with defective guards or shields or without safety devices, for example without the deflector plate or grassbox in place.
- Do not change the engine governor settings or over speed the engine.
- Disengage all blades and drive clutches before starting.
- Start the engine carefully following the instructions with feet well away from the blades.
- Do not tilt the mower when starting the engine.
- Do not put hands or feet near the under rotating parts. Keep clear of the discharge opening at all times.
- Never pick up or carry the mower while the engine is running.

FOR THE LOCATION OF CONTROLS AND COMPONENTS REF “MACHINE DESCRIPTION” PAGE.

## **ON / OFF SWITCH (ITEM 16)**

This switch stops the engine and can be used to do so at anytime during the operation of the machine. Ensure it is in the “ON” position before attempting to start the engine.

## **DEADMANS CONTROL (ITEM 15)**

This is an operator presence control. The engine will tick over without need for this to be depressed when the cutter and drive are disengaged. This must be depressed before the drive or cutter can be engaged. Failure to do so will cause the engine to stop.

## **THROTTLE CONTROL (ITEM 4)**

This controls the RPM of the engine and in conjunction with the selected gear, controls the resultant speed of the machine. Pulling back will increase the RPM, pushing it forwards returns the engine to idle. The maximum engine speed for this machine is set to 2800Rpm when the blades are engaged.

## **DRIVE CONTROL/ BRAKE CONTROL (ITEM 8)**

This controls the machines movement. Pushing the lever forwards will engage the Drive Clutch and Disengage the Brake, causing the machine to move. Returning it to the original position will cause the machine to stop and the Brake to engage. Note: Movement will only occur if a gear is selected, see Gear lever controls.

## **BLADE CONTROL (ITEM 11)**

This controls the drive to the blades. Pulling the lever backwards will engage the clutch and cause the Blades to rotate. Returning it to its original position will cause the Blades to stop.

## **GEAR CONTROL (ITEM 12)**

The machine has 1-Reverse and 5-Forward gears, gear 1 being the slowest. The forward speed can be fine-tuned using the Throttle Control.

## **HEIGHT OF CUT CONTROL (ITEM 10).**

The length of grass after cutting depends on the position of the wheels in relation to the rear roller.

Setting the Height of Cut is done using the knob (item 10). (see fig 1)  
Rotating this Anticlockwise will reduce the length of grass and Clockwise will increase the length of grass. Each click of the control will result in a height change of approximately 0.5mm

When using the Height Gauge (item 14) as shown in fig 1.1, the cut height can be set accurately.

The Height Gauge is stored on the right hand side of the engine (see fig 1)

The Gauge must be removed from the deck before commencing mowing.

After a significant height change (More than 3mm - 4mm) the Deck Angle may need adjusting.

NOTE: Ground conditions can affect the finished Height of Cut. If the ground is soft, the machine will sit lower and result in a lower cut height.

## **DECK TILT CONTROL (ITEM 2)**

To achieve the best possible cut and collection the Tilt angle of the deck can be adjusted. This is achieved using item 2, fig 1

Tilt ON lifts the back of the Deck, Tilt OFF lowers the back of the Deck. Each click of the control will result in an angle change of approximately 0.1 degrees.

The back of the deck should always be higher than the front (Tilt ON). For normal conditions we recommend an angle of 1 to 1.5 degree.

Setting the angle is simple. For 1 to 1.5 degrees of Tilt ,the back of the Deck should be 8mm to 12mm higher than the front.

Alternatively, a digital level can be used to set the Deck angle.

## **FRONT BRUSH**

This is designed to agitate any loose material in front of the mower to aid collection.

This can be set using the adjusters in figure 1.2

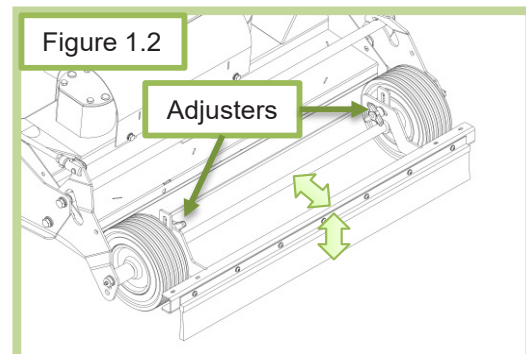
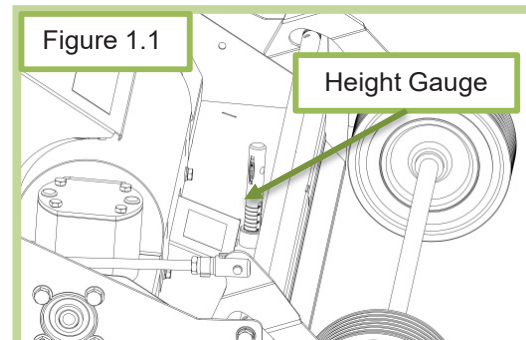
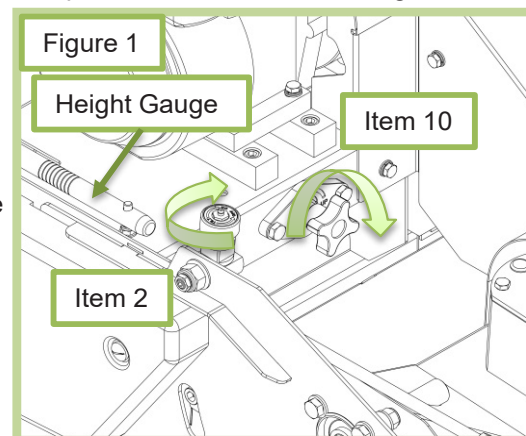





**CAUTION** – *BEFORE YOU OPERATE THIS MACHINE YOU MUST READ AND STUDY THIS MANUAL IF YOU ARE IN ANY DOUBT PLEASE ASK YOUR EMPLOYER OR CONTACT US DIRECT.*

## **PREPARATION FOR USE**

- Before commencing ensure the turf is free from stones and other obstructions which may damage the cassette unit.
- Set the height of the cut to the required level. (see general adjustments)
- Check the engine
- Fill the fuel tank 3/4 full with unleaded petrol.
- Always check the oil levels of the machine prior to commencing. Full details are given in the ENGINE manual, which accompanies this book. A daily check is recommended. (Recommended grade oil is SAE 10W-40).
- Disengage the cassette unit. (see general adjustments)
- Set the throttle control on the handle to the idle position.



**CAUTION** – *IMPORTANT INFORMATION PLEASE READ ALL THE DETAILS IN THIS SECTION AND FAMILIARISE YOURSELF AND ALL MACHINE OPERATORS WITH THE CONTENTS.*

## **STARTING THE ENGINE**

Once the preparatory steps have been completed as outlined on page 7 the engine may be started. (see manufacturer operating manual for full details).

1. Switch on the fuel tap.
2. Switch the handlebar “off switch” to **ON**,
3. Set the throttle control to a half open position.
4. Shift the choke lever to the appropriate position . The choke is not required if the engine is warm or the air temperature is high.
5. Grasp the recoil start handle until resistance is felt, then pull it with force.
6. Do not allow the starter grip to snap back against the engine. Return it gently to prevent damage to the starting position.
7. Once the engine is started, gradually ‘open’ the choke lever (move the lever towards the RUNNING, or OPEN position). Warm-up running of 3-5 minutes is recommended.

## **STOPPING THE ENGINE**

1. Set the throttle control to the CLOSED position.
2. Switch the handlebar cut off to OFF
3. Close the fuel tap.

## **TO COMMENCE DRIVING (TRANSPORT BETWEEN SITES / NO CUTTING)**

- Depress the “Deadmans Handle” (Item 15)
- Push the “Drive Control Lever” (Item 8) forwards.
- Set the “Throttle Control Lever” to increase / reduce speed.

## **TO STOP DRIVING**

- Pull the “Drive Control Lever” (Item 8) backwards. This will engage the brake.

## TO COMMENCE CUTTING

- Depress the “Deadmans Handle” (Item 15)
- Pull the cutter control lever backwards.
- Push the “Drive Control Lever” (Item 8) forwards.
- Set the “Throttle Control Lever” to increase / reduce speed.

## TO STOP CUTTING

- Pull the “Drive Control Lever” (Item 14) backwards.
- Push the cutter control lever forwards.
- Release the “Deadmans Handle” (item 15)



**NOTE** – Releasing the “Deadmans Control Lever” with the blades engaged will cause the engine to stop.

## FITTING THE GRASSBAG (Item 9)

- Ensure cutter drive is disengaged
- Lift the Grassbag cover fig 2
- With the other hand, lift the Grassbag, tilting it back slightly.
- Remove the Grassbag up between the handle bars
- Empty the bag and replace.

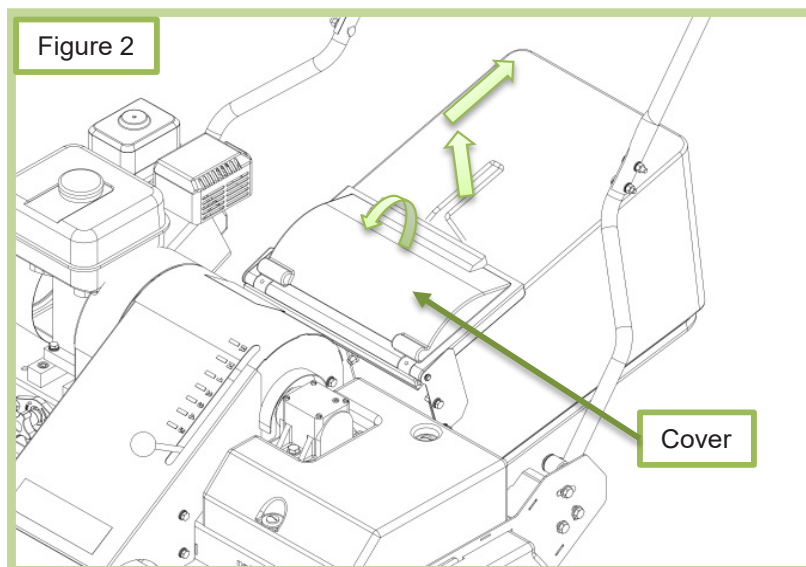



**WARNING** - Shut off engine before commencing any maintenance, service or adjustments.

## **BRAKE**

Engaging the Roller Drive, (Item 8) automatically disengages the Brake. The Brake can be adjusted to ensure it is completely OFF when the Roller Drive is engaged and ON when the Roller Drive is disengaged.

Fig 3 shows the Transmission and Disc Brake mounted beneath the Chassis. The nut highlighted in the diagram is the adjuster for the Brake. With the machine in Neutral, and the Brake engaged (Roller Drive disengaged), adjust the nut until the machine cannot be pushed. Disengage the Brake (engage the Roller Drive), check the machine can be pushed. If the Brake is still engaged, adjust the nut to free it off. Repeat the adjustment until the Brake is fully ON when the Roller Drive is disengaged and OFF when the Roller Drive is engaged.

Figure 3

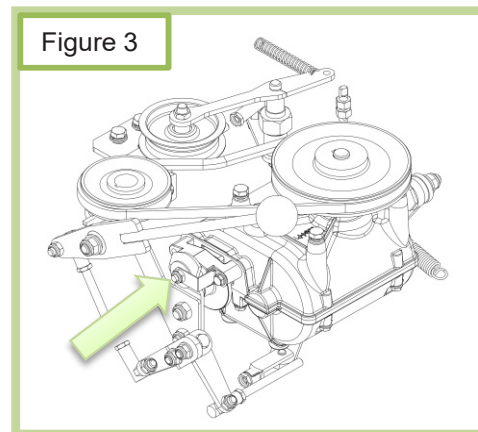

## **ROLLER DRIVE BELT**

This connects the Top Gearbox to the Transmission fig 4. This Belt is clutched when you operate the Roller Drive Lever. This can be adjusted by moving the Top Gearbox on its slotted mountings. Moving the Top Gearbox will require the position of the couplings to be altered on the shafts.

### **Replacement**

A new Roller Drive Belt can be fitted without removing any components (After removing guards)

## **BLADE DRIVE**

The Blade Drive system consists of a Clutch - Brake attached directly to the engine (fig 5). This drives twin 90 degree Gearboxes mounted on the Deck (fig 5) via a special high load "B" section Kevlar V Belt.

### **Clutch - Brake**

There are 2 points of adjustment for the Clutch - Brake, both on the Cable that connects the Clutch - Brake to the Lever (fig 6)

The Clutch - Brake is correctly adjusted when Spring (fig 6), has an extension of between 23mm and 24mm.

When the Clutch - Brake is disengaged the blades should stop within 5 seconds. There should be no "Rubbing" noise coming from the Clutch - Brake. When it is disengaged.

Figure 4

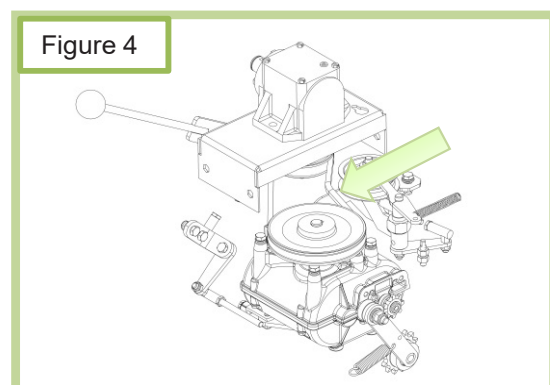

Figure 5

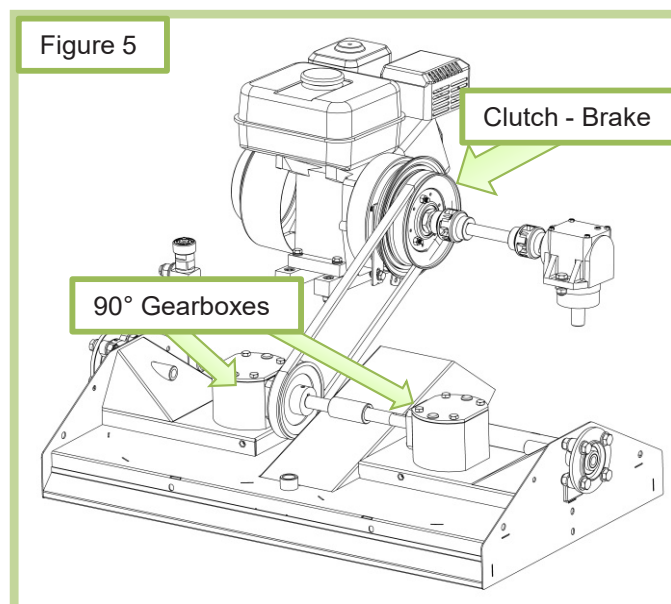
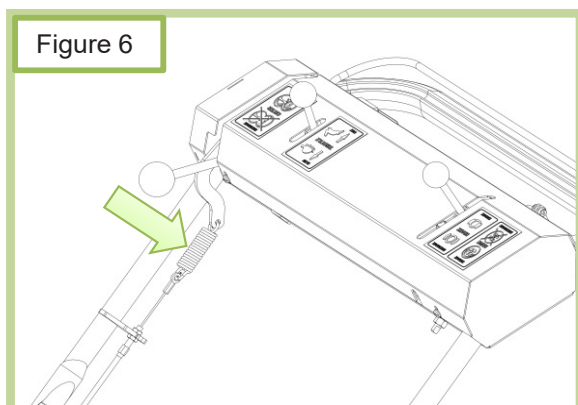

Figure 6



## Cutter Drive Belt

This connects the Clutch – Brake to the Gearboxes on the Deck. There are adjusters mounted on the side plates that allow the deck to be moved forwards. (fig 7). This will tension the Cutter Drive Belt.

The 4-off M10 Bolts each side (fig 7) need to be slackened before any adjustment can be made. Use the adjuster bolts (fig 7) to move the deck forward. Note: It is important that equal adjustment is made on the Left Hand and Right Hand side of the machine.

Sufficient tension is achieved when a 5mm deflection is observed at mid span with a moderate finger pressure.

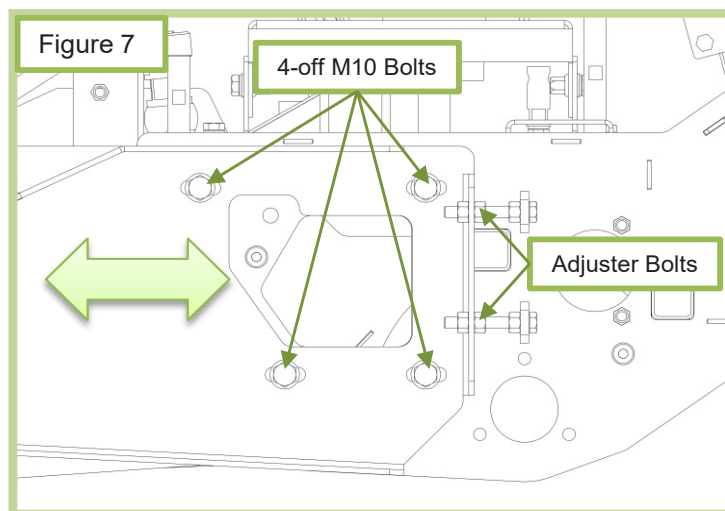

## Belt Replacement

Replacing the Cutter Drive Belt is very simple. (Estimated time 30 minutes)

Remove the plastic plugs in the 90 degree gearboxes (fig 8)  
Remove M10 blade retaining bolts [B] (17mm spanner) to remove blades.

Unbolt the 4-off M10 Caphead bolts that hold the Gearboxes to the deck.[A] (8mm Allen key, 17mm spanner). This allows the gearbox and blade assembly to be raised up.  
Thread the new Belt over the gearbox assembly.  
Replace the Gearbox assembly.

Remove / slacken the bolts highlighted in fig 9.  
Remove the Top Drive shaft.  
Put the new belt over the Clutch Pulley. Note slacken off the belt adjusters (see belt adjustment section)  
Replace the Top Drive Shaft.  
Replace / Tighten bolts in fig 9.  
Adjust the Belt as described in "Belt adjustment section".

Note: The tension of a new Belt should be checked after 30 minutes of running.

An incorrectly adjusted belt will lead to premature wear.

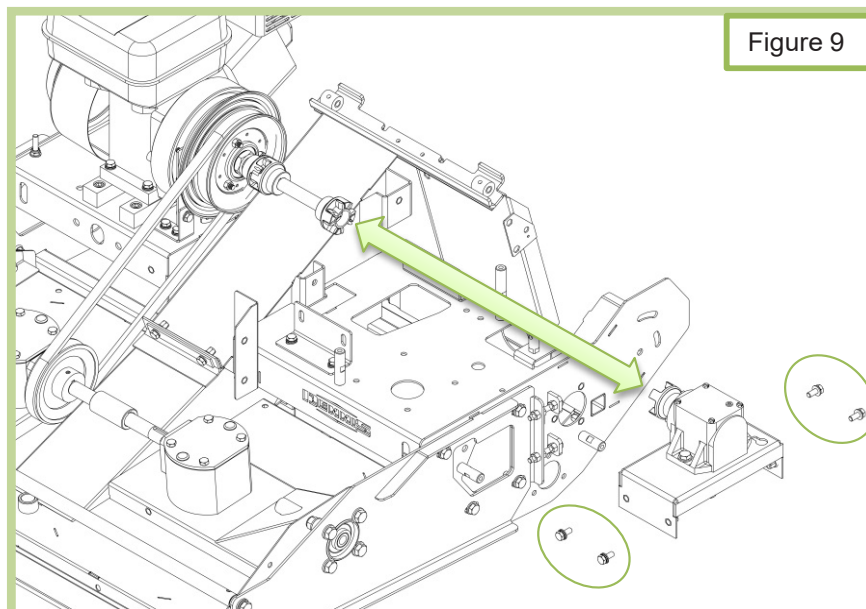
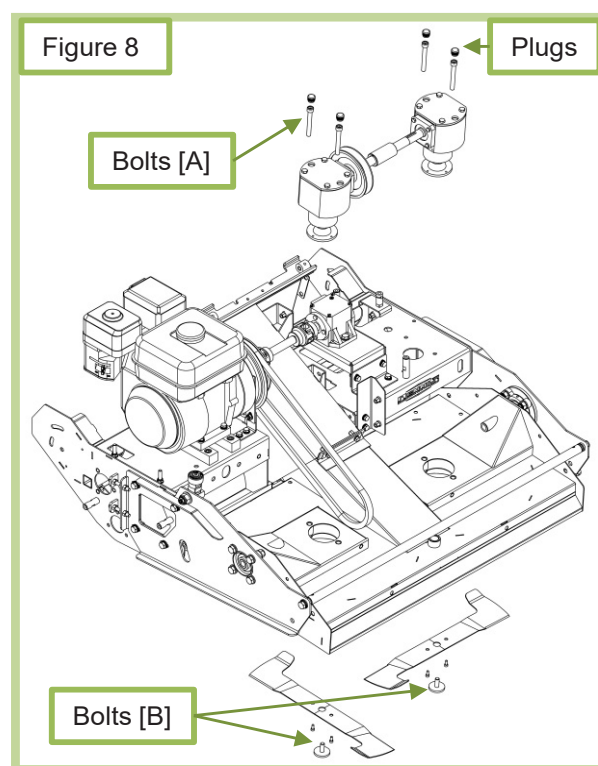

## ENGINE

The machines are fitted with a GX200 petrol engine.  
For full specifications please refer to the manufacturers instruction manual included.

Area	Maintenance	Each Use	First Month / 20 Hours	6 Months / 100 Hours
Engine Oil	Check Level	✓		
Engine Oil	Change		✓	✓
Air Filter	Check Condition / clean	✓	✓	✓
Spark Plug	Change			✓

## OIL / FUEL & QUANTITY – SPARK PLUG TYPE

Engine Model	Oil Types	Quantity (Ltr)	Fuel Type	Capacity (Ltr)	Spark Plug Type	Electrode Gap (mm)
Gx200 Petrol	SAE 10W-30	0.6	unleaded	3.1	BM6ES or BPR6ES	0.7 – 0.8

## BLADES



Worn or damaged blades can be dangerous resulting in serious injury or death of the operator or bystanders.

Blades must be inspected weekly for wear or damage. This can be observed as impact (dents), material cracking and excessive thinning.

Replace worn or damaged blades.

Note: Using non-genuine parts could result in non-compliance with safety standards and may invalidate your warranty.

For details of blades and Torque settings Ref. Section P2 of this manual.

## CLEANING (After Each Use)

### **Deck**

Tilt the machine backwards. Using a low pressure hose, wash all the grass from around the deck and in the chute.  
NOTE: DO NOT use power pressure washers to clean the mower.

### **Grassbag**

Washing with high pressure water or steam jet will damage the bag.  
Blocked mesh will prevent the grass from entering the bag.

To clean the bag, we recommend washing it using a water jet directed from the outside to the inside of the bag. The bag must be completely dry before being used again. If the bag is damp, it will become clogged very quickly.

Objects struck by the blade may be thrown through a torn or damaged grass bag.

Objects thrown out by the blade can cause serious injuries.  
Always replace a torn or damaged bag.

Bag Replacement – The grass bag tends to wear even in normal conditions of use. Regularly check that it is not frayed or torn. Replace a damaged bag only by a genuine Dennis replacement bag.

## **REAR ROLLER CHAIN**

### **(1-month)**

Apply a small amount of grease.

## **WHEEL BEARINGS**

### **(1-months)**

Two grease points on the bolts that hold the wheel axle. Apply one pump of grease to each.

## **CONTROL LEVERS AND CABLES**

### **(2-months)**

Apply a small amount of oil to the control cables. Flow down the protective cables can be assisted by operating the lever a few times after lubricating.

## **TILT CONTROL**

### **(2-months)**

Apply a small amount of grease through the grease nipple. .

## **HEIGHT OF CUT STAINLESS SHAFT**

### **(6-months)**

Apply a small amount of grease through the grease nipple. NOTE: To access this grease point you will need to remove the right hand side guard.

## Storage

The machine should always be kept in a clean dry place, free from condensation. After use ensure that the machine is thoroughly clean, dry and free from grass and mud. Before off season storage smear a thin layer of grease on to the cutter blades and the shear blade.

Under no circumstances must the machine be steam cleaned as this may remove grease from the pre packed bearings.

Because of the nature of lead free petrol we recommend that if the machine is being left unused for more than 2 weeks the carburettor is run dry. Allow the engine to run out of fuel with the fuel tap switched off.



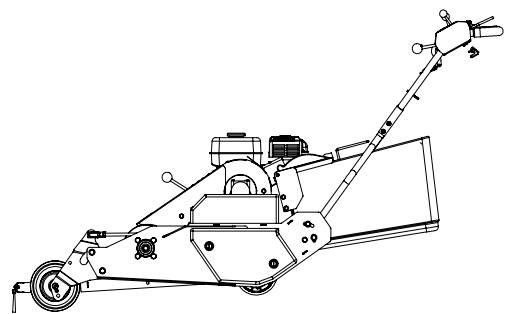
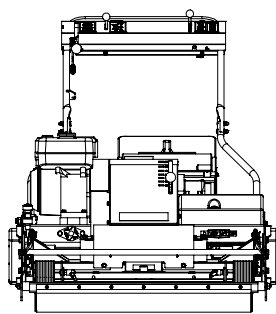
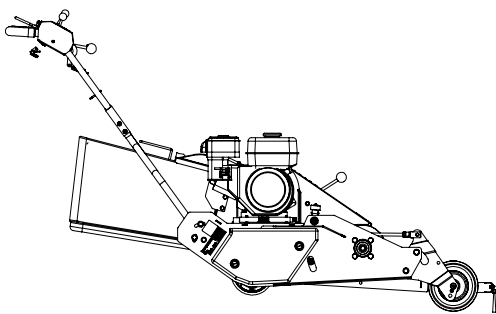
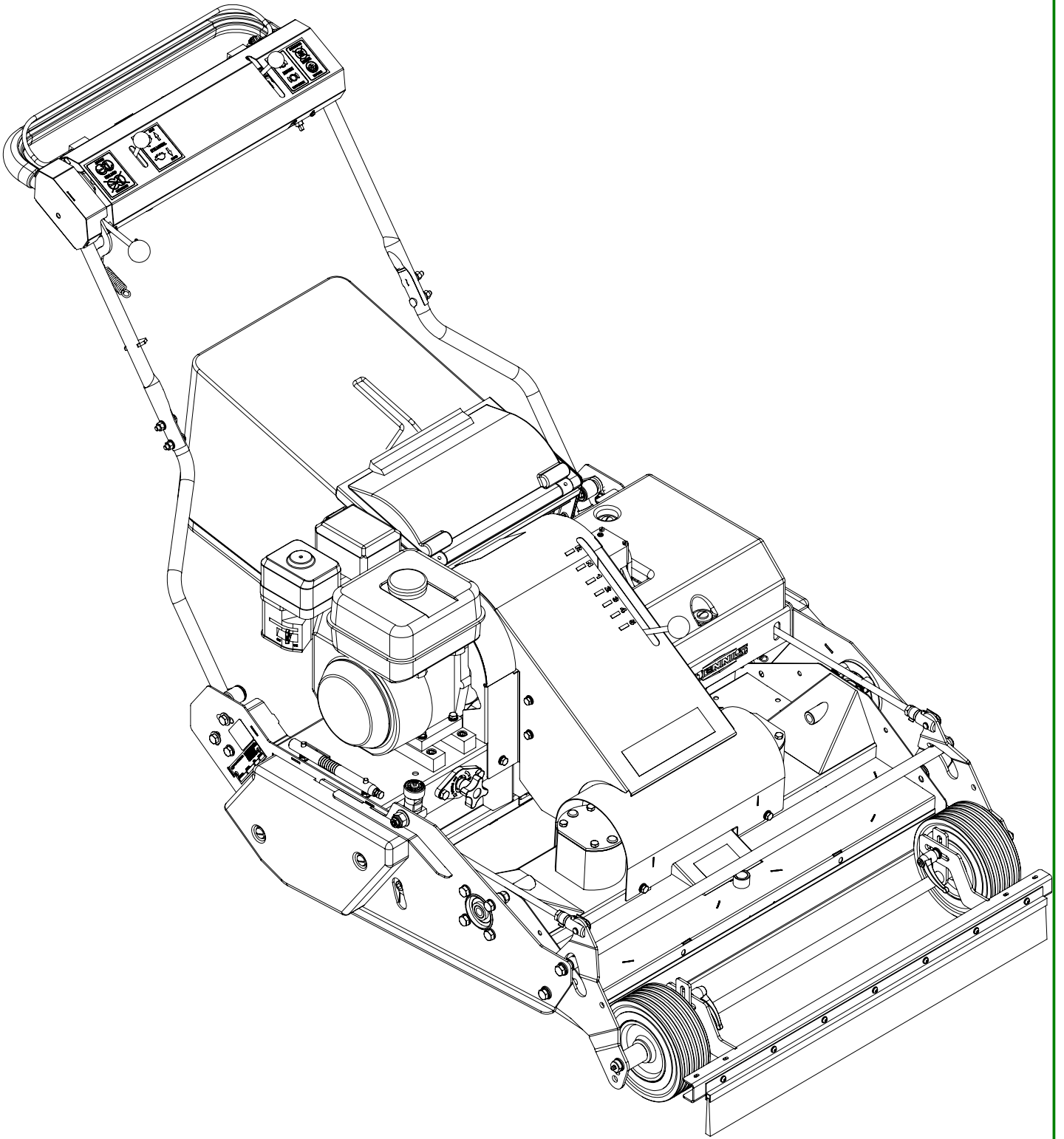



# CHASSIS

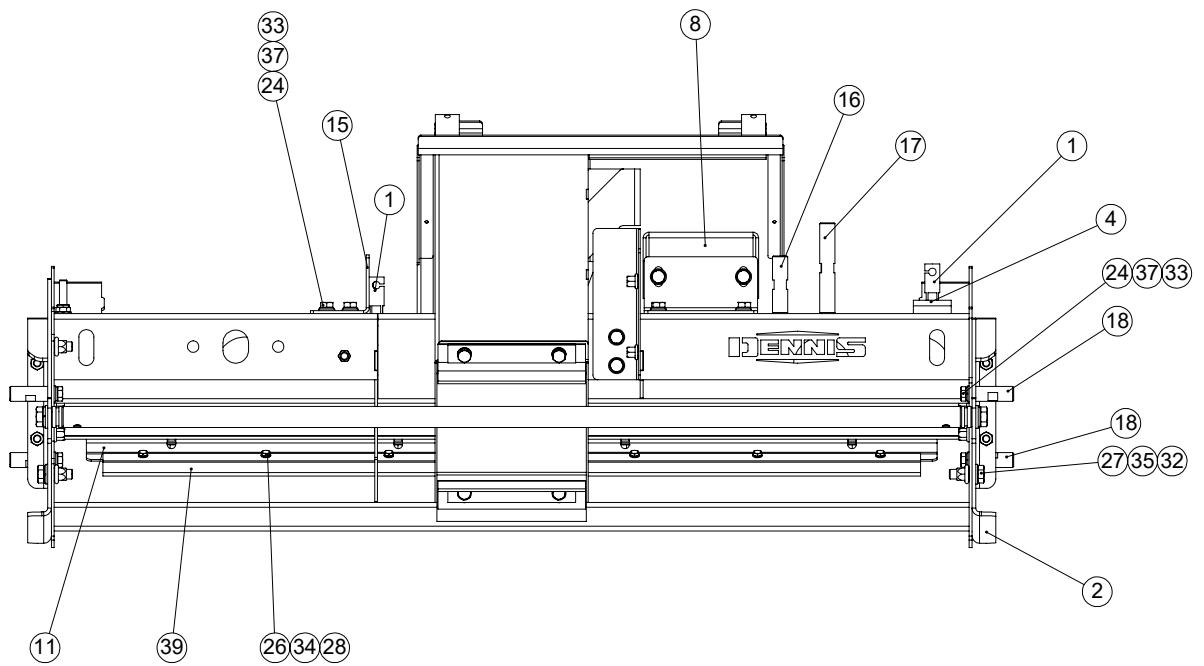
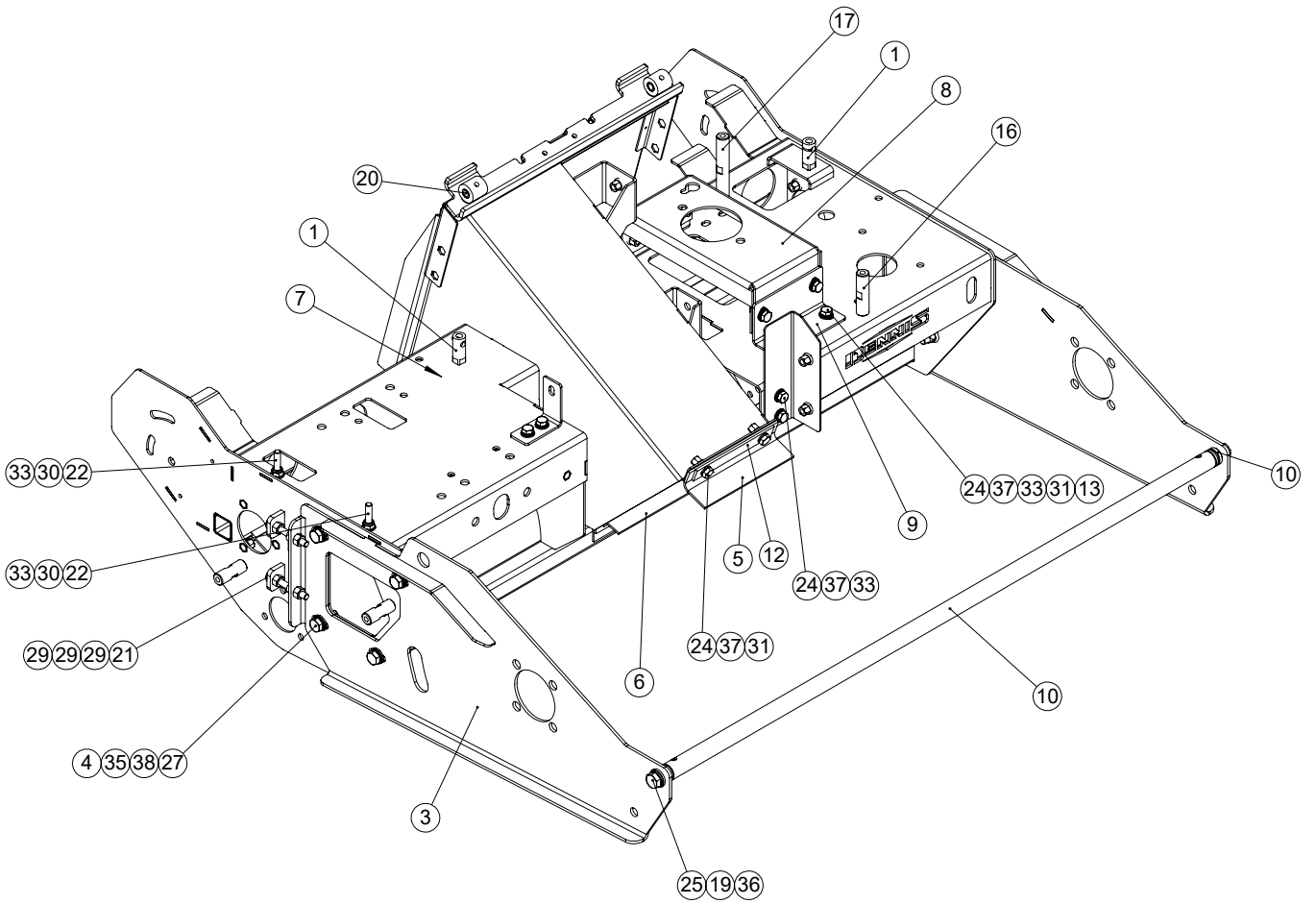

# CHASSIS

ITEM NO.	PART NUMBER	DESCRIPTION	CHASSIS/QTY.
1	229005_REV2	CABLE STOP	2
2	320010_REV0	SIDE PLATE ASSY L.H.	1
3	320011_REV0	SIDE PLATE ASSY R.H.	1
4	320020_REV2	CHASSIS 34" W.A.	1
5	320048_REV0	DECK SEAL	1
6	320048_REV0	DECK SEAL	1
7	320056_REV0	RETAINING PLATE	1
8	320060_REV0	BRACKET GBOX MOUNT	1
9	320061_REV0	BRACKET ANGLE	2
10	320063_REV0	TIE BAR ASSY	1
11	320065_REV0	SCRAPER BRUSH REAR ROLLER	1
12	320066_REV0	SEAL CLAMP	2
13	320067_REV0	PLATE RIVNUT	2
14	320201_REV0	GUARD BRACKET	1
15	320202_REV0	BRACKET ANTI-ROTATION	1
16	320212_REV0	GUARD STUD 61	1
17	320213_REV0	GUARD STUD 96	1
18	320214_REV0	GUARD STUD 44	4
19	E1-1065_REV0	WASHER M12 SPRING LOCK	2
20	F21712_REV1	BUSH NYLON 1208 10	4
21	SP01023_REV0	HEX SET SCREW M8 X 60	4
22	SP01027_REV0	HEX SET SCREW M8 X 40	2
23	SP01034_REV0	HEX SET SCREW M10 X 20	2
24	SP01009_REV0	HEX SET SCREW M8 X 20	26
25	SP01065_REV0	HEX SET SCREW M12 X 30	2
26	SP01074_REV0	HEX SET SCREW M5 X 12	7
27	SP01105_REV0	HEX SET SCREW M10 X 30	8
28	SP02002_REV0	NUT M5 NYLOC (T)	7
29	SP02005_REV0	NUT M8 STD	12
30	SP02006_REV0	NUT M8 NYLOC (T)	2
31	SP02044_REV0	RIVNUT HEX M8 (0.5-3.0) [NO HEAD]	32
32	SP02046_REV0	RIVNUT HEX M10 (1.0-3.5) [NO HEAD]	8
33	SP03008_REV0	WASHER M8 FORM A	27
34	SP03009_REV0	WASHER M5 FORM A	14
35	SP03011_REV0	WASHER M10 FORM A	8
36	SP03012_REV0	WASHER M12 FORM A	2
37	SP03029_REV0	WASHER M8 SPRING LOCK	24
38	SP03034_REV0	WASHER M10 SPRING LOCK	6
39	SP24007_REV0	BRUSH H SECTION 4MM	1

# DECK

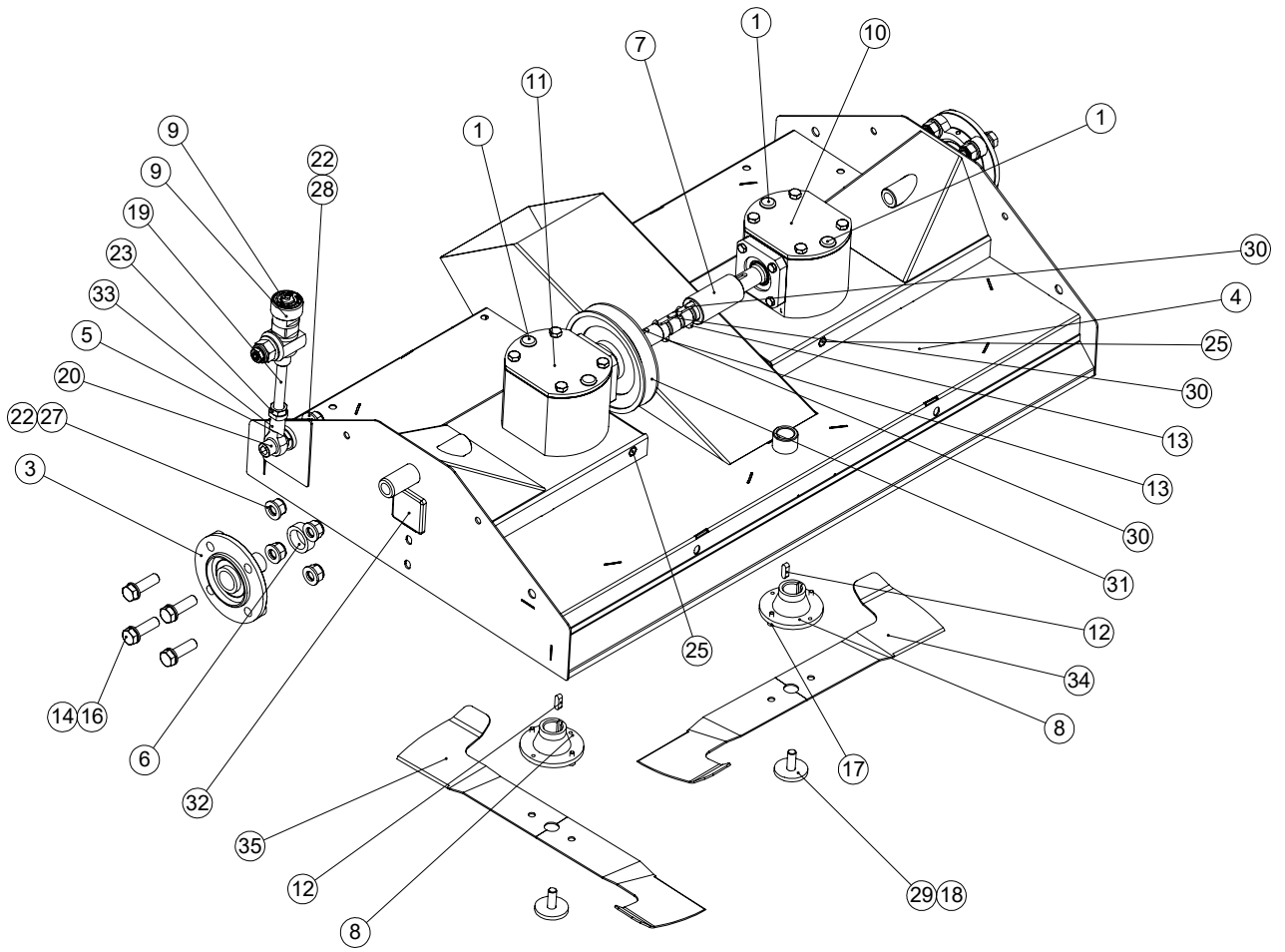

TORQUE TO 40Nm

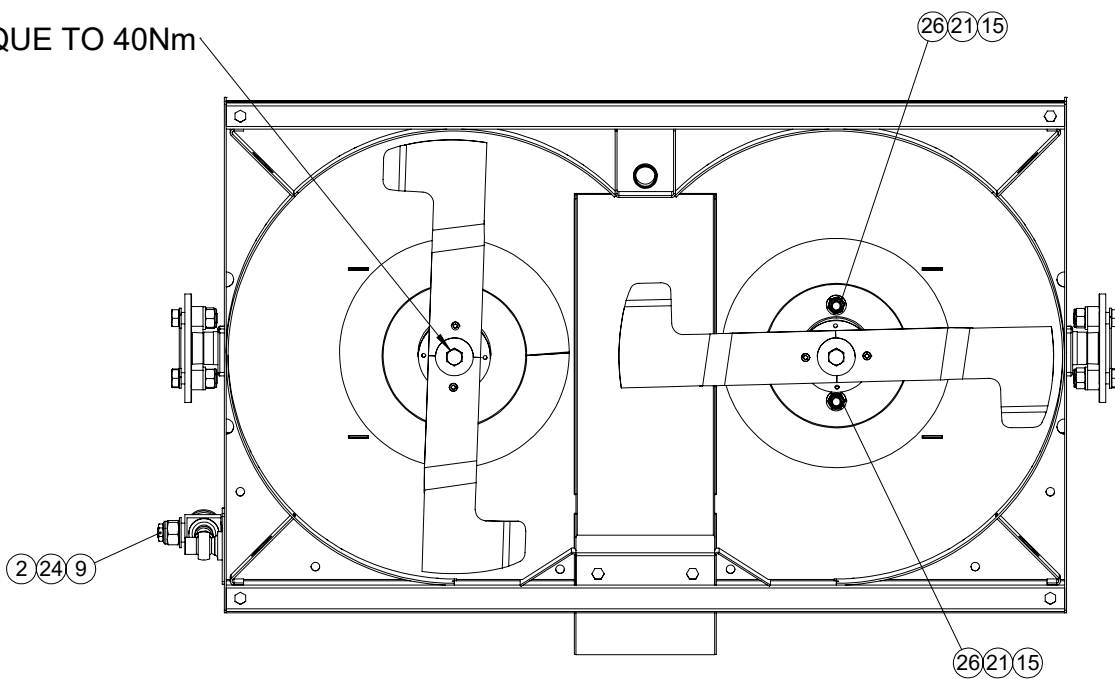

# DECK

ITEM NO.	PART NUMBER	DESCRIPTION	DECK/QTY.
1	228062_REV1	3/4" TUBE BUNG (3132)	4
2	228074_REV1	D315163175 BELLEVILLE WASHER	1
3	229110_REV1	BEARING UCFC205-25	2
4	320030_REV2	DECK 34" W.A.	1
5	320087_REV0	SPACER BOSS	1
6	320088_REV0	DECK PIVOT BOSS	2
7	320143_REV1	COLLAR SHAFT DECK	1
8	320146_REV2	BLADE MOUNT BODY	2
9	800237_REV0	CLICK ADJUSTER ASSY ROTARY	1
10	800549_REV2	GEARBOX ROTARY L.H.	1
11	800550_REV2	GEARBOX ROTARY R.H.	1
12	BA1014_REV0	KEY 6 X 6 X 20 RD END	2
13	D8153_REV1	GRUB SCREW M8 X 10	5
14	E1-1065_REV0	WASHER M12 SPRING LOCK	8
15	SP01061_REV0	CAP HEAD M10 X 80 FULL THREAD	4
16	SP01078_REV0	HEX SET SCREW M12 X 40	8
17	SP01081_REV0	CAP HEAD M5 X 12	4
18	SP01105_REV0	HEX SET SCREW M10 X 30	2
19	SP01152_REV0	ROD M12 X 150	1
20	SP01155_REV0	CAP HEAD M12 X 55	1
21	SP02008_REV0	NUT M10 NYLOC (T)	4
22	SP02010_REV0	NUT M12 NYLOC (T)	9
23	SP02014_REV0	NUT M12 LOCK (THIN)	1
24	SP02028_REV0	NUT M16 NYLOC (T)	1
25	SP02044_REV0	RIVNUT HEX M8 (0.5-3.0) [NO HEAD]	4
26	SP03011_REV0	WASHER M10 FORM A	4
27	SP03012_REV0	WASHER M12 FORM A	8
28	SP03017_REV0	WASHER M12 FORM C	1
29	SP03037_REV0	WASHER 10.5 X 40 X 5	2
30	SP10005_REV0	KEY 6 X 6 X 30 RD END	3
31	SP11054_REV0	PULLEY V SPB 125	1
32	SP14011_REV0	INSERT 50MM SQ. 1.0-3.0	2
33	SP14022_REV0	ROD END M12 FEMALE	1
34	SP22007A_REV0	BLADE ROTARY L.H.	1
35	SP22007B_REV0	BLADE ROTARY R.H.	1

# REAR ROLLER

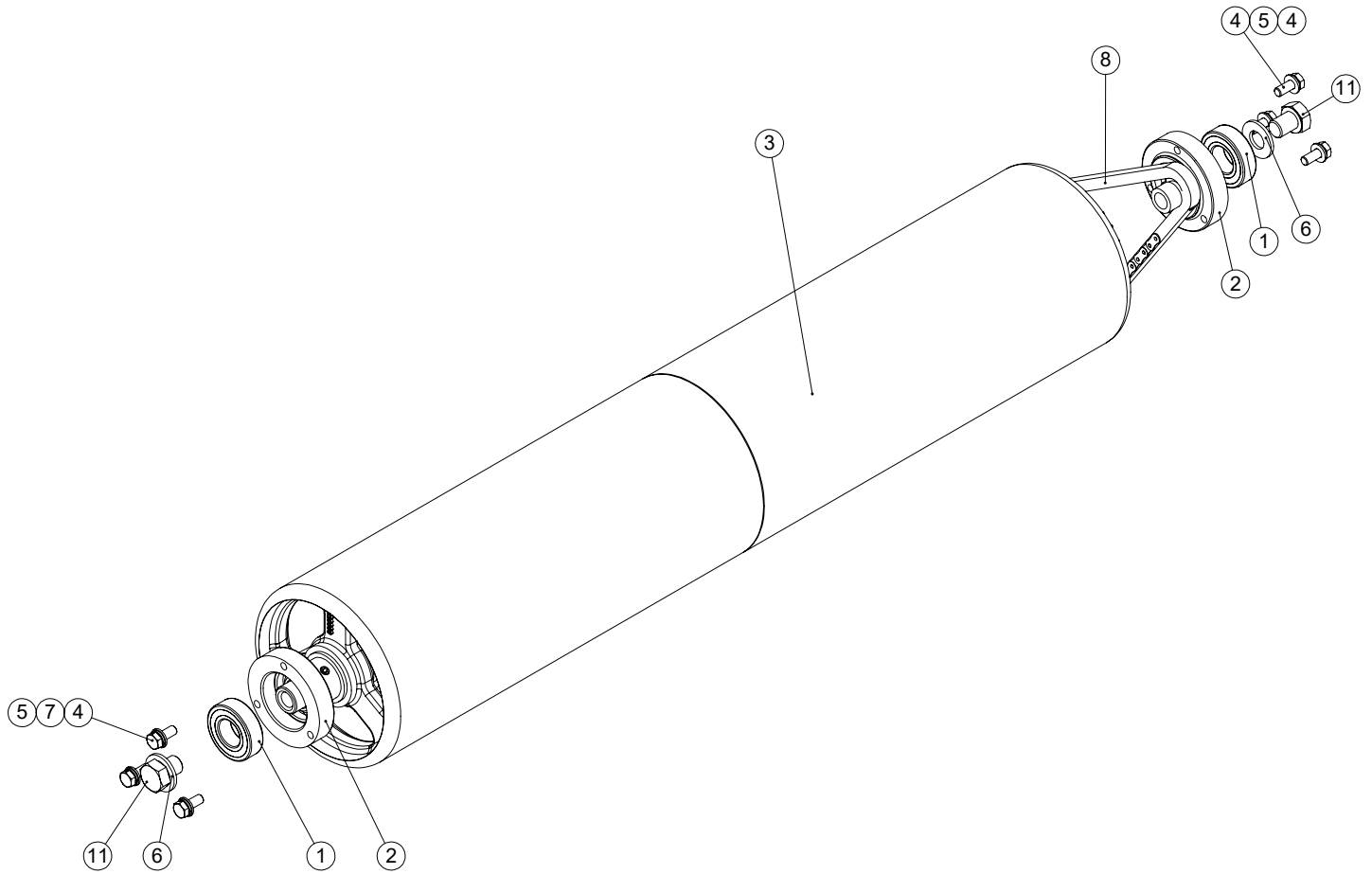

ITEM NO.	PART NUMBER	DESCRIPTION	REAR ROLLER/QTY.
1	062662_REV1	BEARING 6205-2RS 3	2
2	229104_REV1	LANDROLL BEARING HOUSING	2
3	800236_REV0	REAR ROLLER	1
4	SP01009_REV0	HEX SET SCREW M8 X 20	6
5	SP03008_REV0	WASHER M8 FORM A	6
6	SP03021_REV0	WASHER M16 FORM C	2
7	SP03029_REV0	WASHER M8 SPRING LOCK	6
8	SP11061_REV1	CHAIN 08B (1/2" PITCH)	1
9	SP02014_REV0	NUT M12 LOCK (THIN)	2
10	402055_REV0	AXLE SPACER	1
11	SP01075_REV0	HEX SET SCREW M16 X 20	2
12	SP11057_REV0	GEARBOX 700101	1
13	J209025_REV0	KEY 3/16" X 3/16" X 1 3/4" RD END	1
14	229233_REV1	FRONT ROLLER 34"	1
15	SP02054_REV0	NUT M12 BINK	2

# REAR ROLLER - 800236

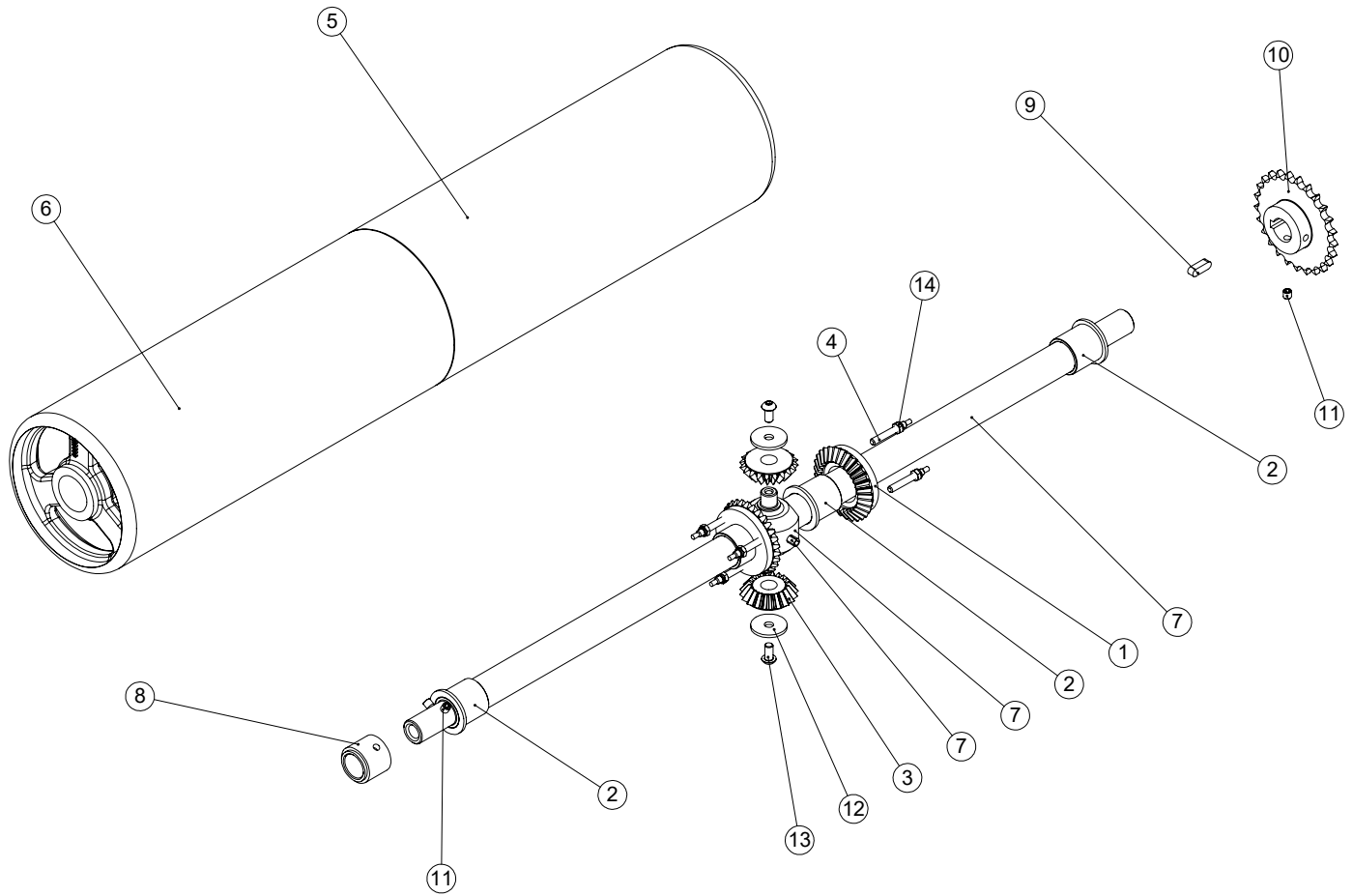

ITEM NO.	PART NUMBER	DESCRIPTION	QTY.
1	229022_REV1	30 TOOTH BEVEL GEAR	2
2	229023_REV1	BUSH AJ2024 - 1 1/2"	4
3	229025_REV2	BEVEL GEAR 20T	2
4	229118_REV3	GEAR STUD	6
5	320100_REV0	ROLLER L.H.	1
6	320120_REV0	ROLLER R.H.	1
7	320130_REV1	ROLLER SHAFT ASSY	1
8	320132_REV0	ROLLER COLLAR	1
9	F20684_REV0	KEY PARALLEL 8 X 7 X 25	1
10	F31077_REV1	SPROCKET 08B 25T	1
11	J20467_REV0	GRUB SCREW M8 X 8	4
12	J209249_REV0	WASHER 9 X 35 X 3	2
13	SP01048_REV0	BUTTON HEAD M8 X 16	2
14	SP02039_REV0	NUT 1/4" NYLOC (P)	6

# GEAR BOX LEFT

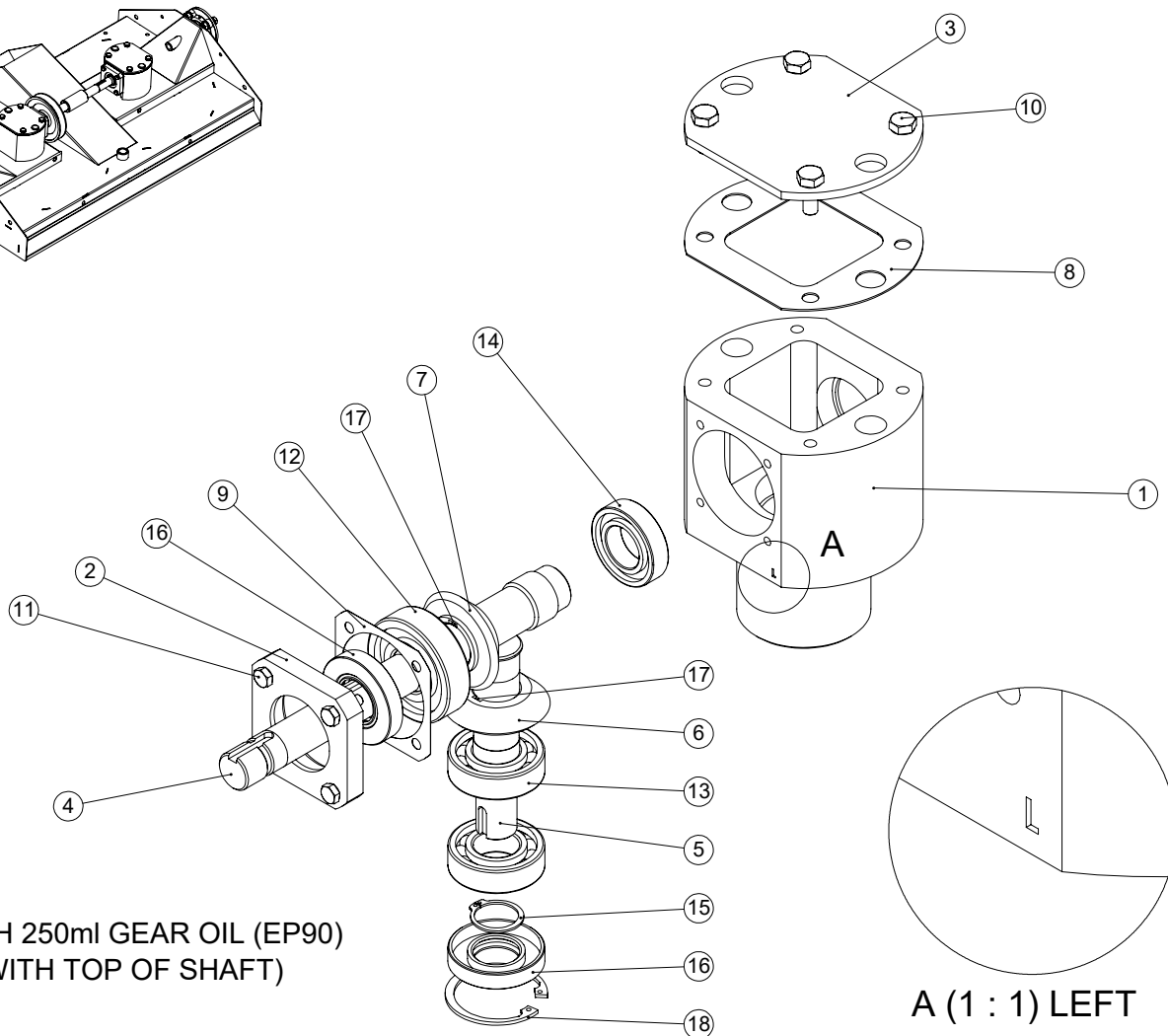
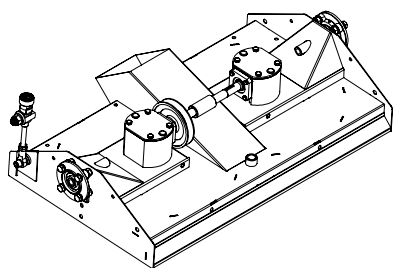

FILL WITH 250ml GEAR OIL (EP90)  
(LEVEL WITH TOP OF SHAFT)

A (1 : 1) LEFT

ITEM NO.	PART NUMBER	DESCRIPTION	QTY.
1	320250_REV2	GEARBOX BODY	1
2	320251_REV0	GEARBOX END CAP	1
3	320252_REV0	GEARBOX LID	1
4	320253_REV5	GEARBOX SHAFT INPUT	1
5	320254_REV5	GEARBOX SHAFT OUTPUT	1
6	320256_REV0	GEAR SPIROL BEVEL A	1
7	320257_REV0	GEAR SPIROL BEVEL B	1
8	320258_REV0	GEARBOX GASKET LID	1
9	320259_REV0	GEARBOX GASKET CAP	1
10	SP01009_REV0	HEX SET SCREW M8 X 20	4
11	SP01028_REV0	HEX SET SCREW M6 X 20	4
12	SP06027_REV0	BEARING 6305	1
13	SP06028_REV0	BEARING 6205	2
14	SP06029_REV0	BEARING 6005	1
15	SP07011_REV0	CIRCLIP D1400-25	1
16	SP08003_REV0	SEAL DOUBLE LIP 52 X 25 X 10	2
17	SP10011_REV0	KEY PARALLEL 6 X 6 X 15	2
18	228042_REV0	CIRCLIP D1300 0520	1

# GEAR BOX RIGHT

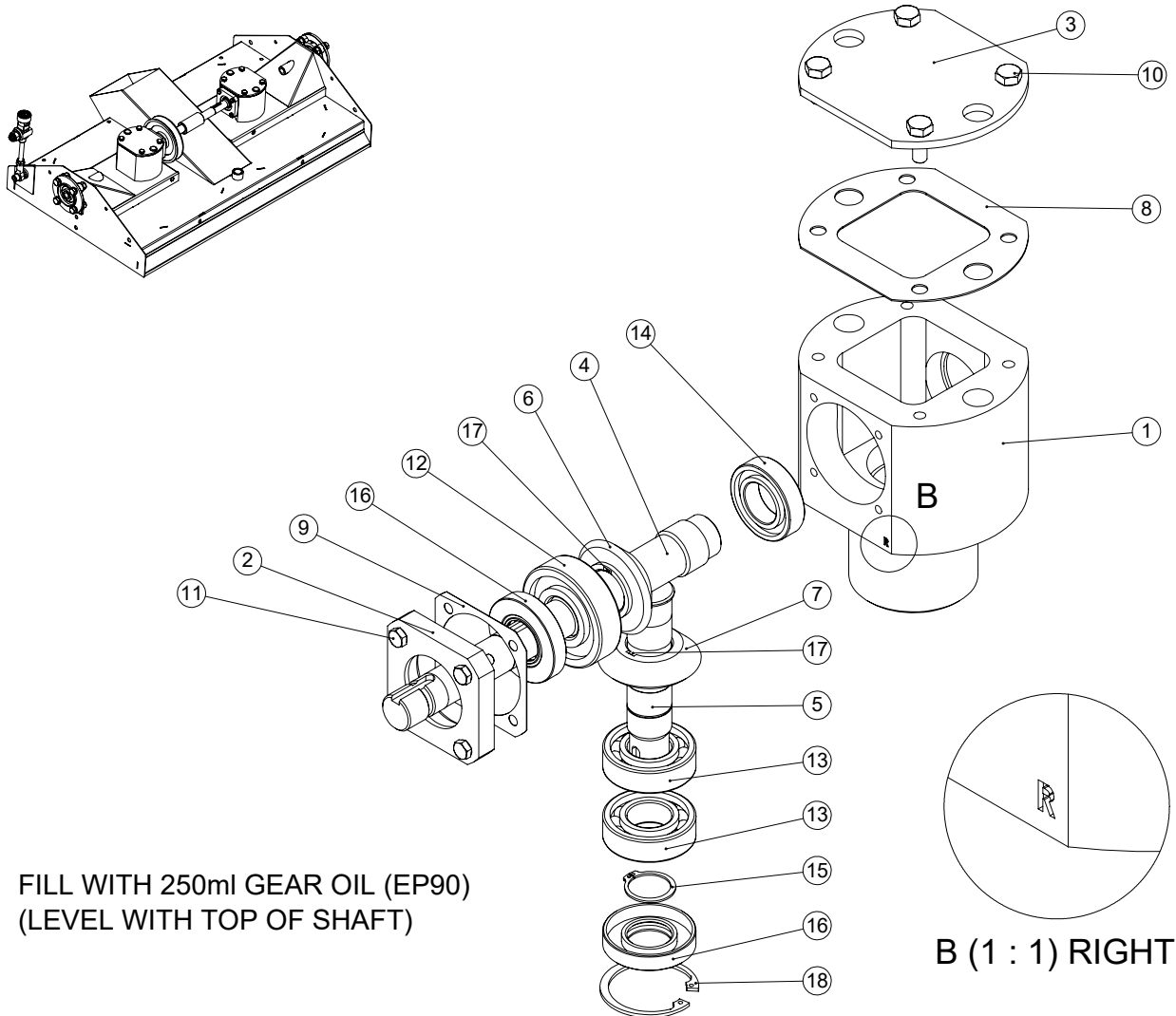

FILL WITH 250ml GEAR OIL (EP90)  
(LEVEL WITH TOP OF SHAFT)

B (1 : 1) RIGHT

ITEM NO.	PART NUMBER	DESCRIPTION	QTY.
1	320250_REV2	GEARBOX BODY	1
2	320251_REV0	GEARBOX END CAP	1
3	320252_REV0	GEARBOX LID	1
4	320253_REV5	GEARBOX SHAFT INPUT	1
5	320254_REV5	GEARBOX SHAFT OUTPUT	1
6	320256_REV0	GEAR SPIROL BEVEL A	1
7	320257_REV0	GEAR SPIROL BEVEL B	1
8	320258_REV0	GEARBOX GASKET LID	1
9	320259_REV0	GEARBOX GASKET CAP	1
10	SP01009_REV0	HEX SET SCREW M8 X 20	4
11	SP01028_REV0	HEX SET SCREW M6 X 20	4
12	SP06027_REV0	BEARING 6305	1
13	SP06028_REV0	BEARING 6205	2
14	SP06029_REV0	BEARING 6005	1
15	SP07011_REV0	CIRCLIP D1400-25	1
16	SP08003_REV0	SEAL DOUBLE LIP 52 X 25 X 10	2
17	SP10011_REV0	KEY PARALLEL 6 X 6 X 15	2
18	228042_REV0	CIRCLIP D1300 0520	1



# ENGINE

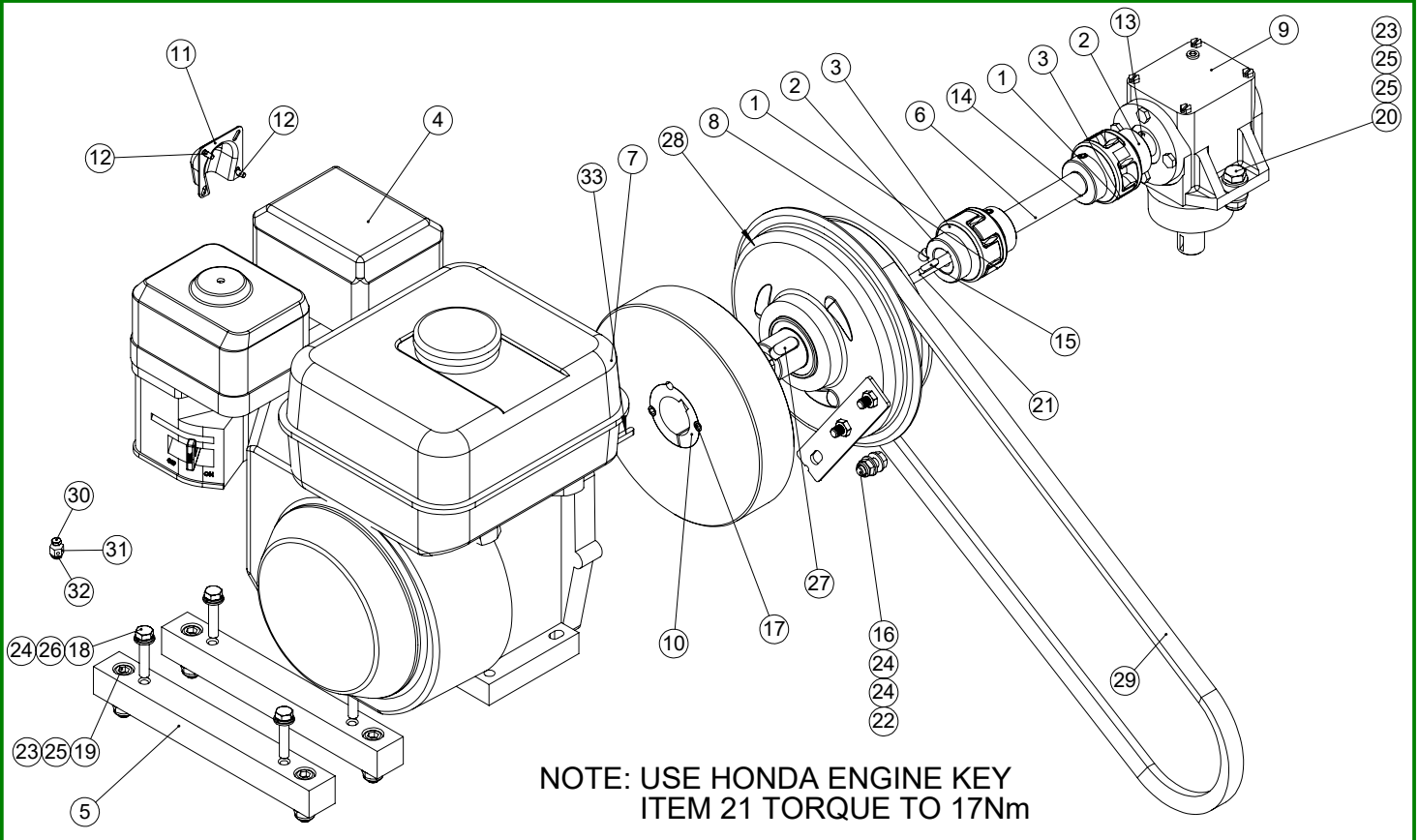

ITEM NO.	PART NUMBER	DESCRIPTION	ENGINE/QTY.
1	228011_REV2	COUPLING HALF (3/4")	2
2	228102_REV1	COUPLING HALF (7/8")	2
3	228103_REV1	COUPLING ELEMENT	2
4	229902_REV1	ENGINE 6.5 HP HONDA GX200 Q9 TYPE	1
5	320080_REV0	ENGINE SPACER	2
6	320141_REV0	DRIVE SHAFT TOP	1
7	320285_REV0	FLYWHEEL	1
8	D8153_REV1	GRUB SCREW M8 X 10	4
9	F20527_REV0	GEARBOX ANGLE DRIVE R.H.	1
10	F22059_REV1	TAPERED BUSH 1610 - 35	1
11	J20367_REV0	EXHAUST DEFLECTOR	1
12	J20368_REV0	SCREW M4 EXHAUST DEFLECTOR	2
13	J20462_REV0	KEY WOODRUFF (606) 3/16" X 3/4"	1
14	J209029_REV1	KEY 3/16" X 3/16" X 7/8" RD END	2
15	J209030_REV1	KEY 3/16" X 3/16" X 3/4" RD END	1
16	SP01009_REV0	HEX SET SCREW M8 X 20	1
17	SP01018_REV0	GRUB SCREW M10 X 16	2
18	SP01027_REV0	HEX SET SCREW M8 X 40	4
19	SP01052_REV0	CAP HEAD M10 X 35	4
20	SP01105_REV0	HEX SET SCREW M10 X 30	2
21	SP01159_REV0	HEX BOLT 5/16" UNF X 3 3/4"	1
22	SP02006_REV0	NUT M8 NYLOC (T)	1
23	SP02008_REV0	NUT M10 NYLOC (T)	6
24	SP03008_REV0	WASHER M8 FORM A	6
25	SP03011_REV0	WASHER M10 FORM A	8
26	SP03029_REV0	WASHER M8 SPRING LOCK	5
27	SP10010_REV0	KEY 10 X 8 X 25	1
28	SP11052_REV1	CLUTCH CB269	1
29	SP11058_REV0	BELT B50 ARAMID CORED	1
30	SP01039_REV0	HEX SET SCREW M4 X 6	1
31	J20376_REV1	THROTTLE CLAMP	1
32	J20369_REV0	E CLIP 5MM	1
33	J209025_REV0	KEY 3/16" X 3/16" X 1 3/4" RD END	1

# HANDLEBARS

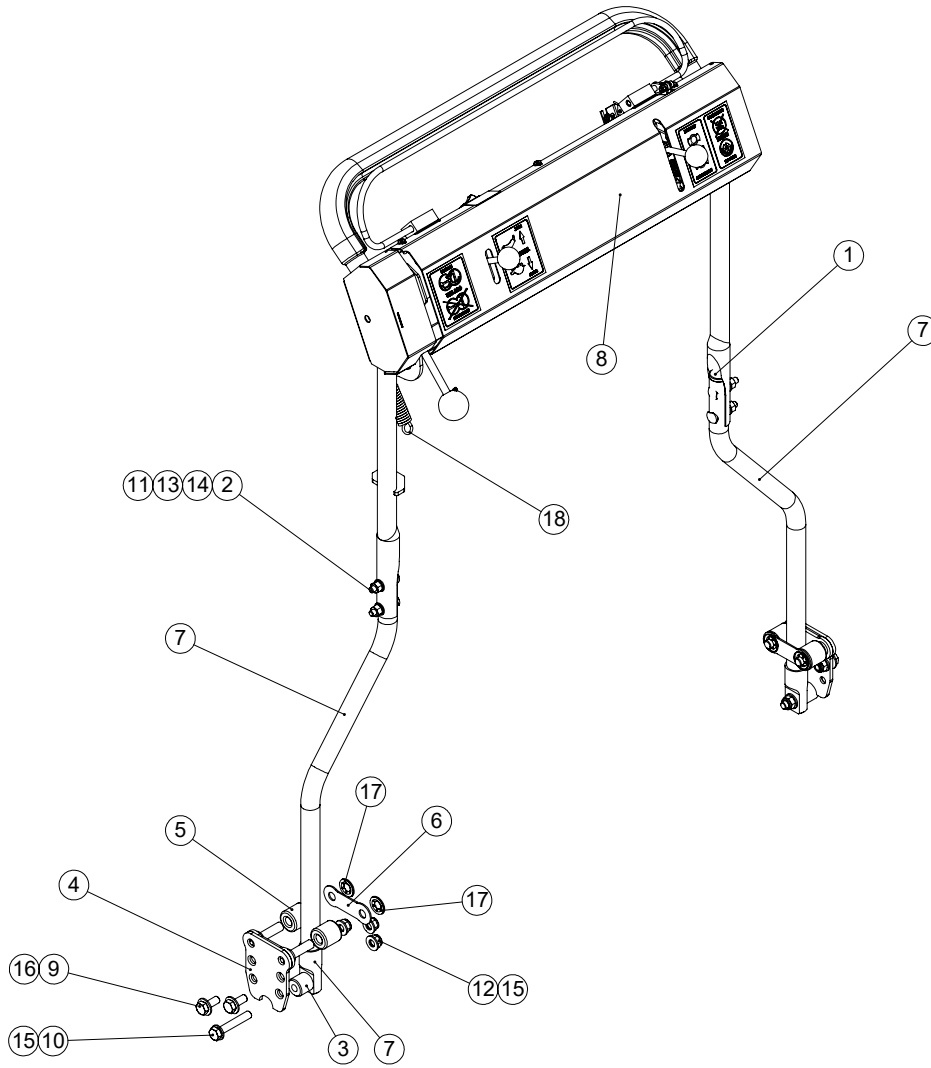

ITEM NO.	PART NUMBER	DESCRIPTION	QTY.
1	228024_REV1	1" TUBE BUNG	2
2	228093_REV0	BOLT SADDLE M8 X 43	4
3	229166_REV1	HANDLE PIVOT BUSH	2
4	230200_REV0	HANDLE BRACKET W.A.	2
5	230203A_REV0	HANDLE BUFFER (PU)	4
6	230205_REV0	HANDLE BRACKET SUPPORT	2
7	320245_REV0	LOWER HANDLE ASSY ROTARY	2
8	800244_REV0	ROTARY UPPER HANDLE ASSY	1
9	SP01035_REV0	HEX SET SCREW M10 X 25	4
10	SP01047_REV0	HEX SET SCREW M10 X 60	2
11	SP02005_REV0	NUT M8 STD	4
12	SP02008_REV0	NUT M10 NYLOC (T)	6
13	SP03004_REV0	WASHER M8 TOOTHED	4
14	SP03008_REV0	WASHER M8 FORM A	4
15	SP03011_REV0	WASHER M10 FORM A	8
16	SP03016_REV0	WASHER M10 FORM C	4
17	SP07001_REV0	STARLOCK 12MM	4
18	SP13010_REV0	EXTENSION SPRING 19.2 X 82.3 X 3	1

### CABLES NOT SHOWN

PART NUMBER	DESCRIPTION	Cables/QTY.
SP12064_REV0	CABLE DRIVE ROTARY	1
SP12065_REV0	CABLE CLUTCH ROTARY	1
SP12070_REV0	THROTTLE CABLE ROTARY	1
SP13011_REV0	CABLE RETURN SPRING	1

# HANDLEBARS

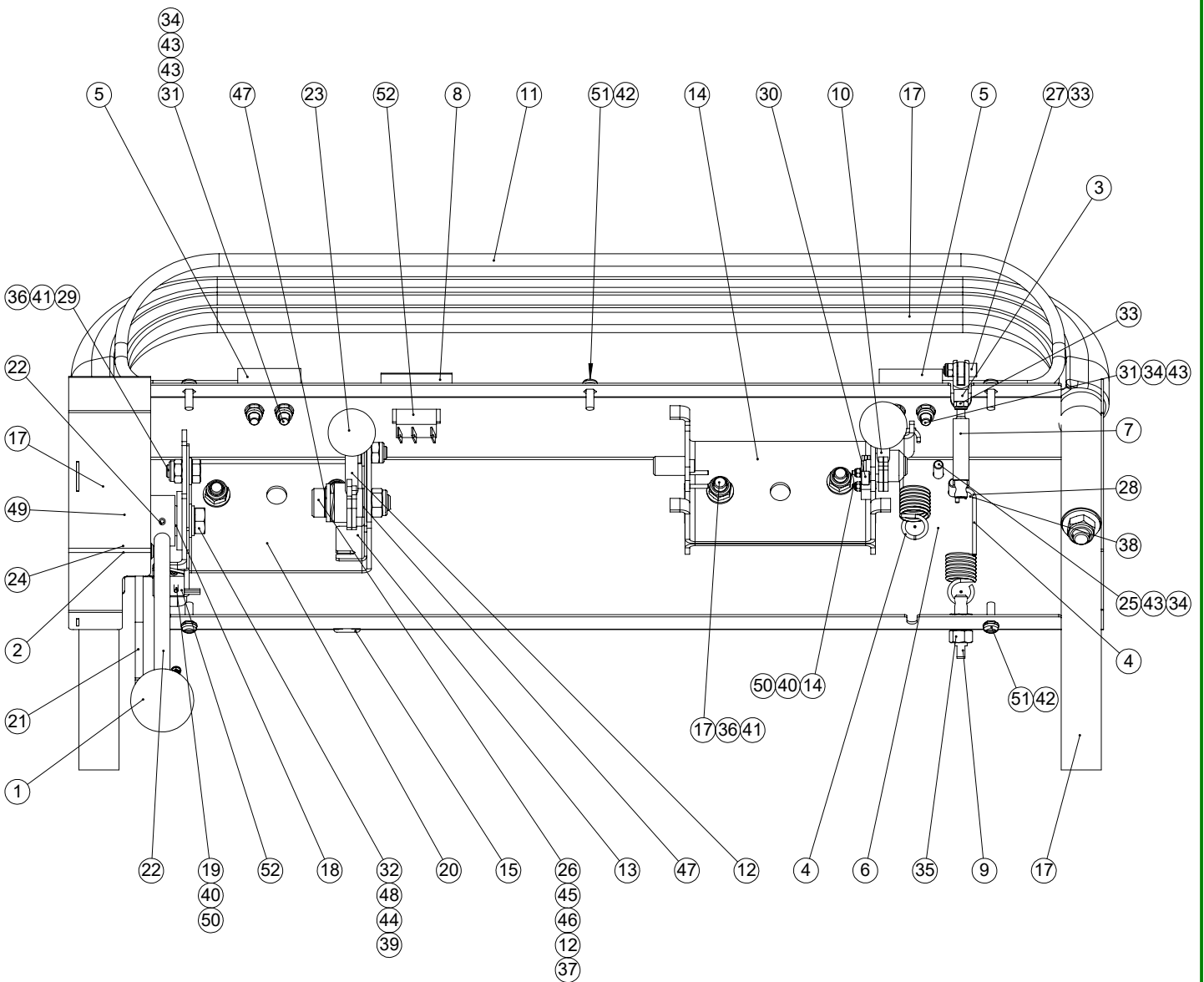
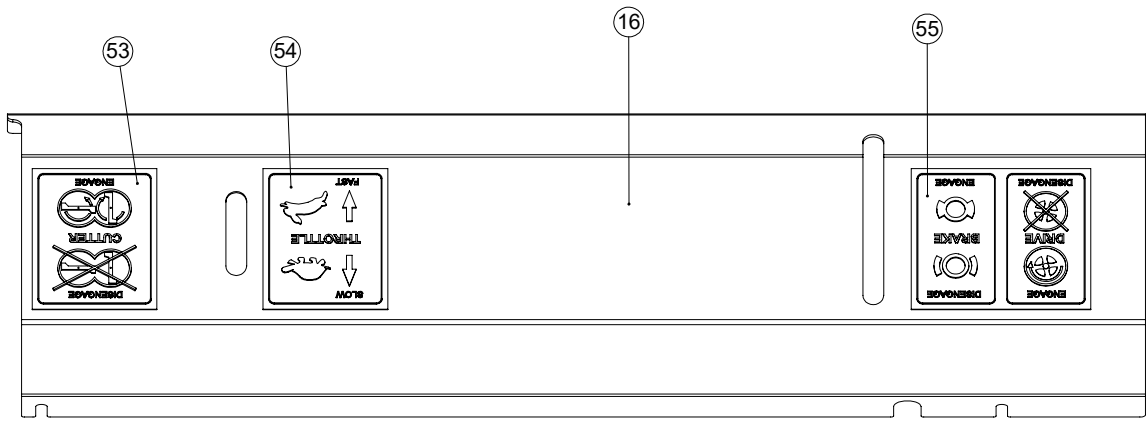

# HANDLEBARS

ITEM NO.	PART NUMBER	DESCRIPTION	Default/QTY.
1	127434_REV1	RED KNOB M10	1
2	192749_REV1	CLEVIS PIN 1/4" X 3/4"	1
3	228020_REV1	CLEVIS GM5 (5MM)	1
4	229167_REV1	CLUTCH SPRING	2
5	229585_REV1	PIVOT BLOCK	2
6	229590_REV1	SAFETY SWITCH BRACKET	1
7	229595_REV2	SAFETY LEVER PLUNGER W.A.	1
8	229599_REV1	DECAL ENGINE ON / OFF	1
9	229620_REV2	BOLT FOR SPRING	1
10	230171_REV2	LEVER L.H. W.A.	1
11	230180_REV0	SAFETY BAR W.A.	1
12	230190_REV1	THROTTLE LEVER W.A. **	1
13	230196_REV2	THROTTLE PLATE	1
14	230207_REV1	LEVER BRACKET ASSY	1
15	260138_REV1	GROMMET PV270A	1
16	320205_REV0	HANDLE COVER	1
17	320270_REV1	ROTARY HANDLE MOULDING	1
18	320274_REV1	CONTROL PIVOT BAR	1
19	320275_REV0	SENSOR BRACKET ASSY	1
20	320276_REV0	CONTROL BRACKET BODY	1
21	320280_REV0	OVER CENTER ARM	1
22	320281_REV0	CLUTCH LEVER	1
23	J20017_REV1	KNOB - RED	2
24	J209021_REV0	SPLIT PIN 1/16" X 1/2"	1
25	SP01019_REV0	BUTTON HEAD M6 X 16	2
26	SP01029_REV0	SHOULDER BOLT 12 X 25 M10	1
27	SP01043_REV0	CAP HEAD M5 X 16	1
28	SP01070_REV0	CAP HEAD M2 X 12	2
29	SP01076_REV0	HEX SET SCREW M8 X 16	4
30	SP01081_REV0	CAP HEAD M5 X 12	1
31	SP01101_REV0	SCREW M6 X 25 SLOTTED	4
32	SP01145_REV0	HEX SET SCREW M10 X 65	1
33	SP02002_REV0	NUT M5 NYLOC (T)	2
34	SP02004_REV0	NUT M6 NYLOC	6
35	SP02005_REV0	NUT M8 STD	2
36	SP02006_REV0	NUT M8 NYLOC (T)	6
37	SP02008_REV0	NUT M10 NYLOC (T)	1
38	SP02038_REV0	NUT M2 (BUSH)	2
39	SP02046_REV0	RIVNUT HEX M10 (1.0-3.5) [NO HEAD]	1
40	SP02059_REV0	NUT M2.5 NYLOC (P)	4
41	SP03008_REV0	WASHER M8 FORM A	6
42	SP03009_REV0	WASHER M5 FORM A	5
43	SP03010_REV0	WASHER M6 FORM A	7
44	SP03011_REV0	WASHER M10 FORM A	1
45	SP03012_REV0	WASHER M12 FORM A	1
46	SP03019_REV0	WASHER M12 WAVE	1
47	SP03020_REV0	SHIM 12 X 18 X 1	2
48	SP03034_REV0	WASHER M10 SPRING LOCK	1
49	SP03036_REV0	WASHER 3/4" (TABLE 3 HEAVY)	2
50	SP03039_REV0	WASHER M2.5 FORM A	4
51	SP04001_REV0	SCREW M5 X 16 SLOTTED	5
52	SP12067_REV0	HARNESS HANDLE ROTARY	1
53	SP18021_REV0	DECAL ROTARY CUT	1
54	SP18022_REV0	DECAL ROTARY CUT	1
55	SP18024_REV0	DECAL DRIVE / BRAKE	1

# DRIVE SYSTEM

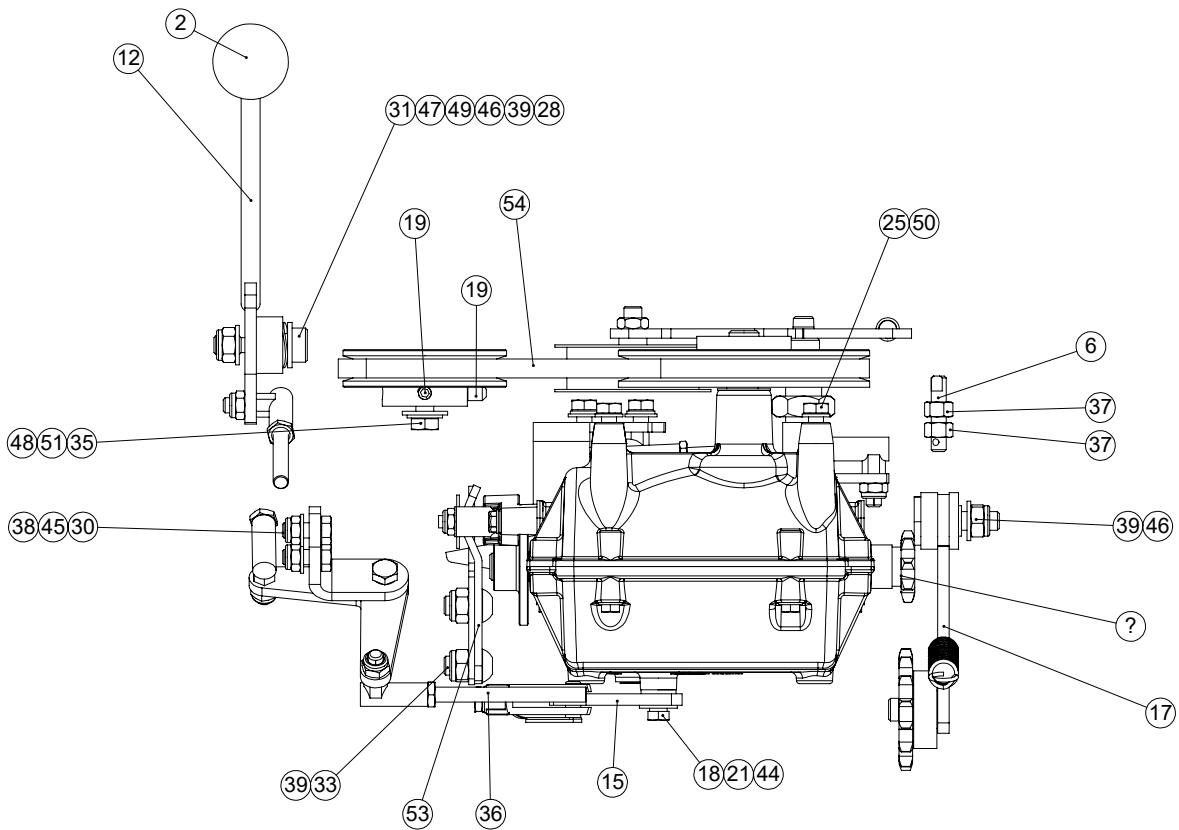
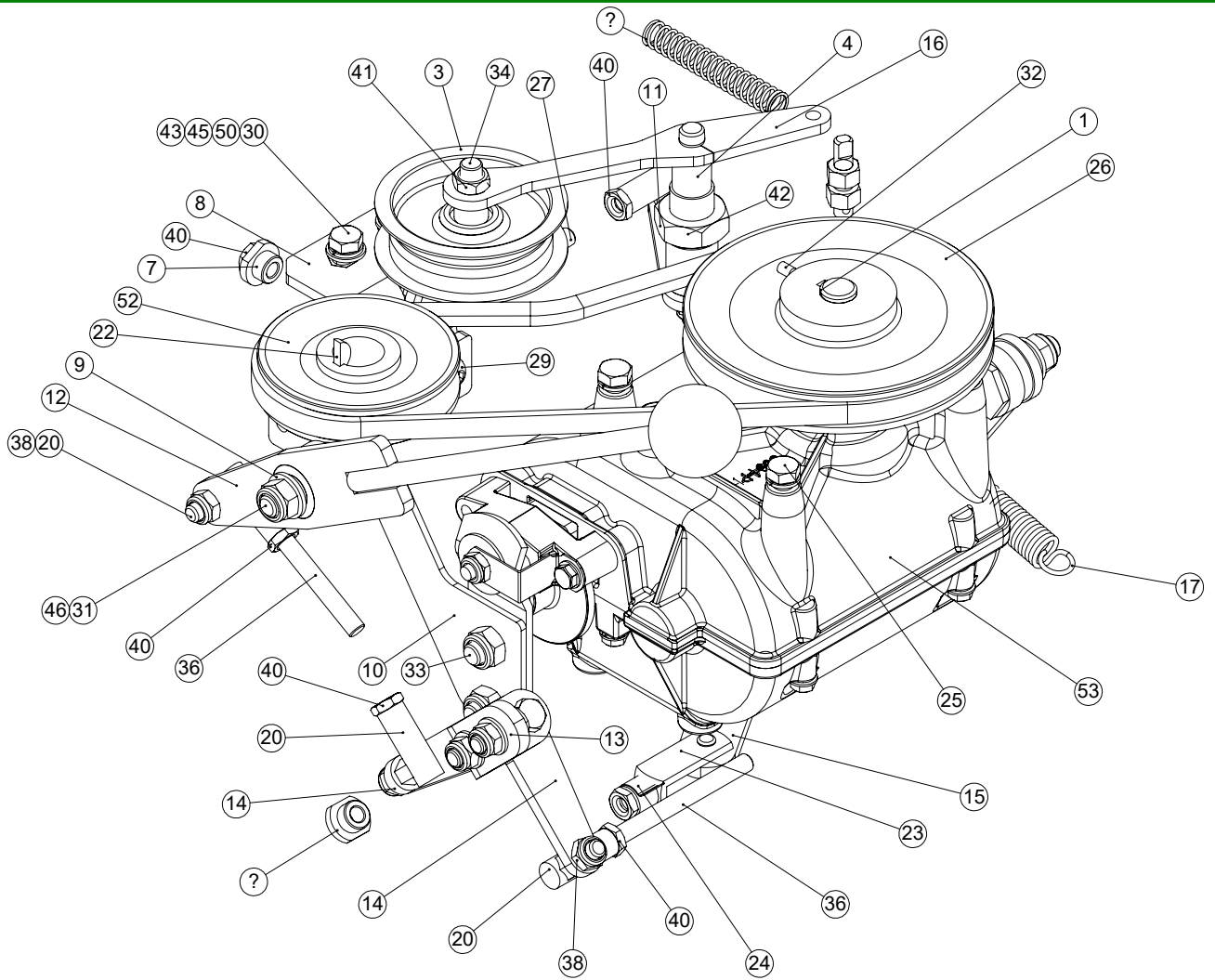

# DRIVE SYSTEM

ITEM NO.	PART NUMBER	DESCRIPTION	DRIVE/QTY.
1	J20462_REV0	KEY WOODRUFF (606) 3/16" X 3/4"	1
2	176457_REV1	BLACK KNOB M10	1
3	229038_REV1	TENSIONER PULLEY	1
4	229382_REV1	BRG HOUSING	1
5	229422_REV1	CABLE RETURN SPRING	1
6	229620_REV2	BOLT FOR SPRING	1
7	320069_REV0	LINKAGE BOSS	2
8	320077_REV0	BRACKET BRAKE ACTUATOR	1
9	320079_REV0	ARM BRAKE ACTUATOR	1
10	320090_REV0	LEVER BRAKE	1
11	320091_REV0	LEVER BRAKE RELEASE	1
12	320092_REV0	LEVER GEAR W.A.	1
13	320095_REV0	BRACKET GEAR TRANSFER	1
14	320096_REV0	LINK GEAR TRANSFER	1
15	320097_REV0	LINK GEAR CHANGE	1
16	320260_REV0	DRIVE LEVER ASSY	1
17	800541_REV0	CHAIN TENSIONER	1
18	D1239_REV0	HEX SET SCREW 1/4" UNF X 3/4"	1
19	D8153_REV1	GRUB SCREW M8 X 10	2
20	D8485_REV1	ROD END R108-M8.	5
21	E1-1061_REV0	WASHER M6 SPRING	1
22	F20558_REV1	WOODRUFF KEY NO6 (505)	1
23	F21463_REV1	CLEVIS 8MM LONG	1
24	F21464_REV1	CLEVIS CLIP M8 LONG	1
25	F22240_REV0	HEX SET SCREW 5/16" UNC X 3/4"	4
26	F35954_REV1	PULLEY (5" P.C.D.)	1
27	J20553_REV1	ROD M8 X 60	1
28	J209085_REV1	BUSH AM1216 - 20	1
29	SP01006_REV0	BUTTON HEAD M8 X 20	1
30	SP01009_REV0	HEX SET SCREW M8 X 20	5
31	SP01029_REV0	SHOULDER BOLT 12 X 25 M10	1
32	SP01051_REV0	GRUB SCREW M5 X 10	1
33	SP01062_REV0	BUTTON HEAD M10 X 20	2
34	SP01071_REV0	HEX SET SCREW 3/8" UNF X 1 1/2"	1
35	SP01095_REV0	HEX SET SCREW 3/8" UNF X 1"	1
36	SP01162_REV0	ROD M8 X 90	2
37	SP02005_REV0	NUT M8 STD	2
38	SP02006_REV0	NUT M8 NYLOC (T)	8
39	SP02008_REV0	NUT M10 NYLOC (T)	4
40	SP02012_REV0	NUT M8 LOCK (THIN)	7
41	SP02033_REV0	NUT 3/8" UNF LOCK (THIN)	1
42	SP02034_REV0	NUT 3/4" UNF STD	1
43	SP02045_REV0	RIVNUT HEX M8 (4.0-6.0) [NO HEAD]	2
44	SP03007_REV0	WASHER M6 X 20	1
45	SP03008_REV0	WASHER M8 FORM A	5
46	SP03011_REV0	WASHER M10 FORM A	2
47	SP03012_REV0	WASHER M12 FORM A	1
48	SP03016_REV0	WASHER M10 FORM C	1
49	SP03019_REV0	WASHER M12 WAVE	1
50	SP03029_REV0	WASHER M8 SPRING LOCK	6
51	SP03034_REV0	WASHER M10 SPRING LOCK	1
52	SP11056_REV0	PULLEY V SPA 80 7/8" BORE	1
53	SP11057_REV0	GEARBOX 700101	1
54	SP11059_REV0	BELT Z 722Ld / 10 X 700 Li Z 27.5 ARAMID CORED	1

# DRIVE SYSTEM

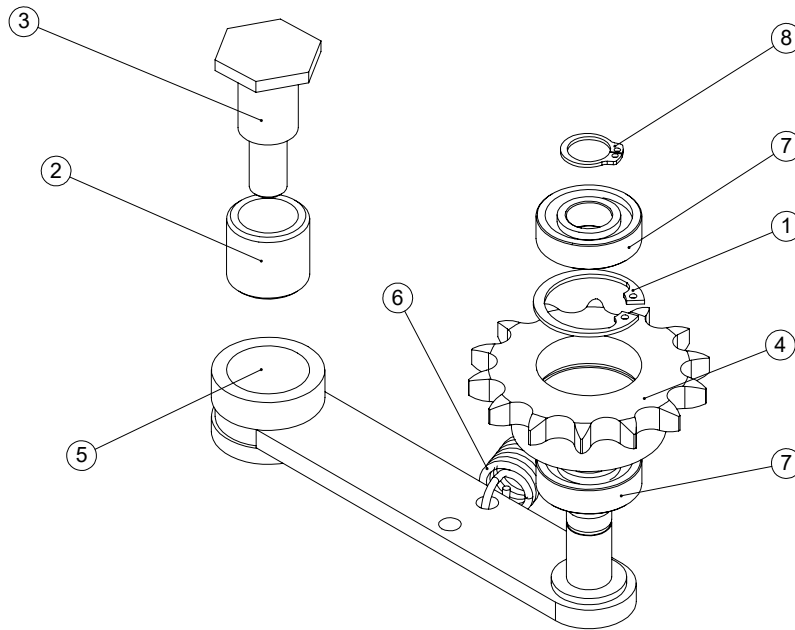

ASSEMBLY NUMBER: 800541

ITEM NO.	PART NUMBER	DESCRIPTION	QTY.
1	229829_REV1	CIRCLIP D1300 0280	1
2	229833_REV1	BUSH AL1622 - 20	1
3	D6182_REV1	TENSIONER PIVOT SHAFT	1
4	D6189_REV1	JOCKEY TENSIONER	1
5	D7979_REV1	JOCKEY TENSIONER ARM	1
6	D8042_REV1	EXTENSION SPRING	1
7	D8173_REV1	BEARING 6001 2RS	2
8	D8175_REV1	CIRCLIP D1400 - 012	1

# GRASSBOX

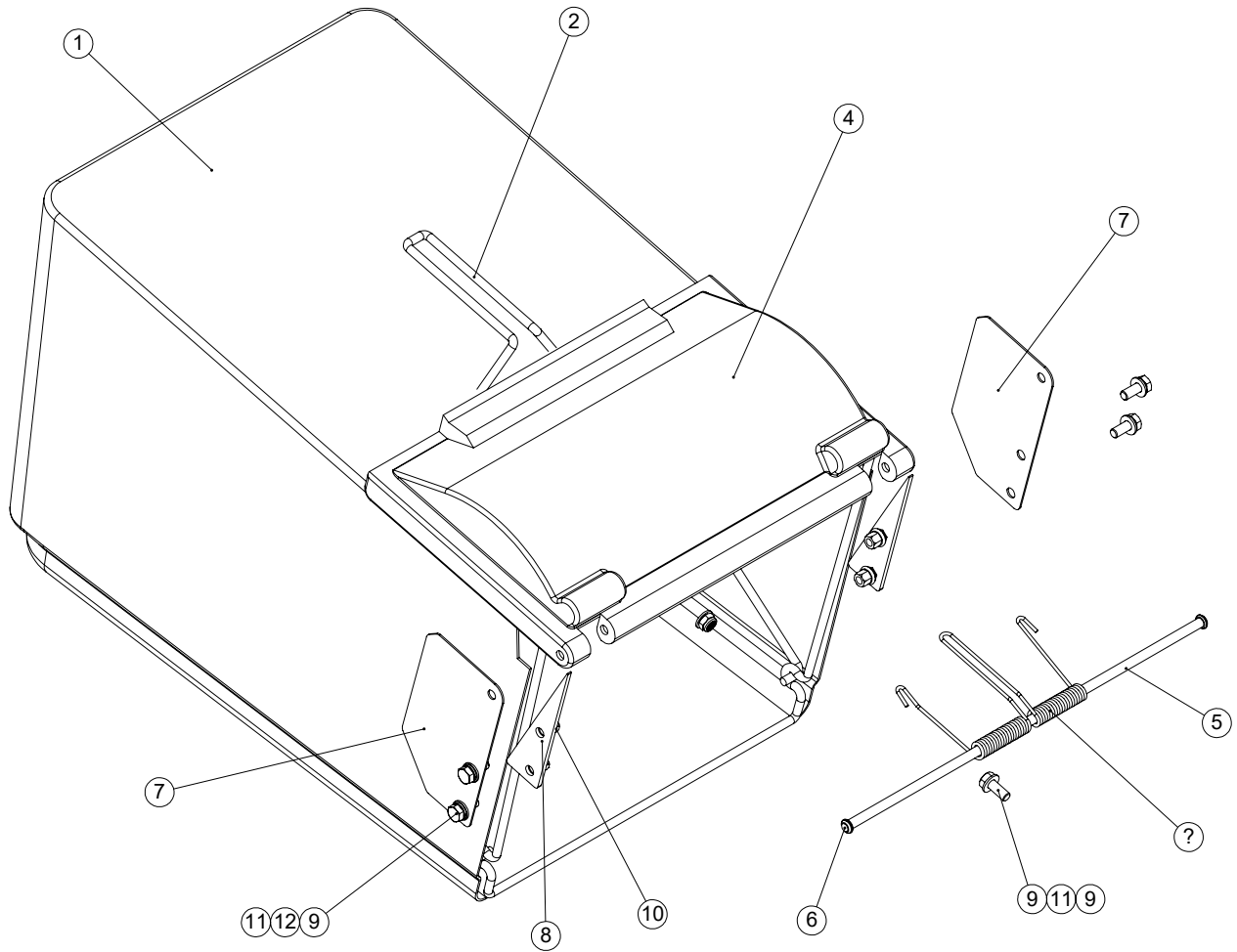

ITEM NO.	PART NUMBER	DESCRIPTION	QTY.
1	320171_REV0	GRASSBAG COVER	1
2	320172_REV0	GRASSBOX FRAME	1
3	320176_REV1	GRASSBAG SPRING	1
4	320177_REV0	GRASSBAG LID	1
5	320178_REV0	GRASSBAG PIVOT	1
6	320179_REV0	PIVOT BAR CLIP	2
7	320180_REV1	DEFLECTOR	2
8	320181_REV1	DEFLECTOR SPACER	2
9	SP01009_REV0	HEX SET SCREW M8 X 20	5
10	SP02044_REV0	RIVNUT HEX M8 (0.5-3.0) [NO HEAD]	4
11	SP03008_REV0	WASHER M8 FORM A	6
12	SP03029_REV0	WASHER M8 SPRING LOCK	4
13	SP02006_REV0	NUT M8 NYLOC (T)	1



# GUARDS

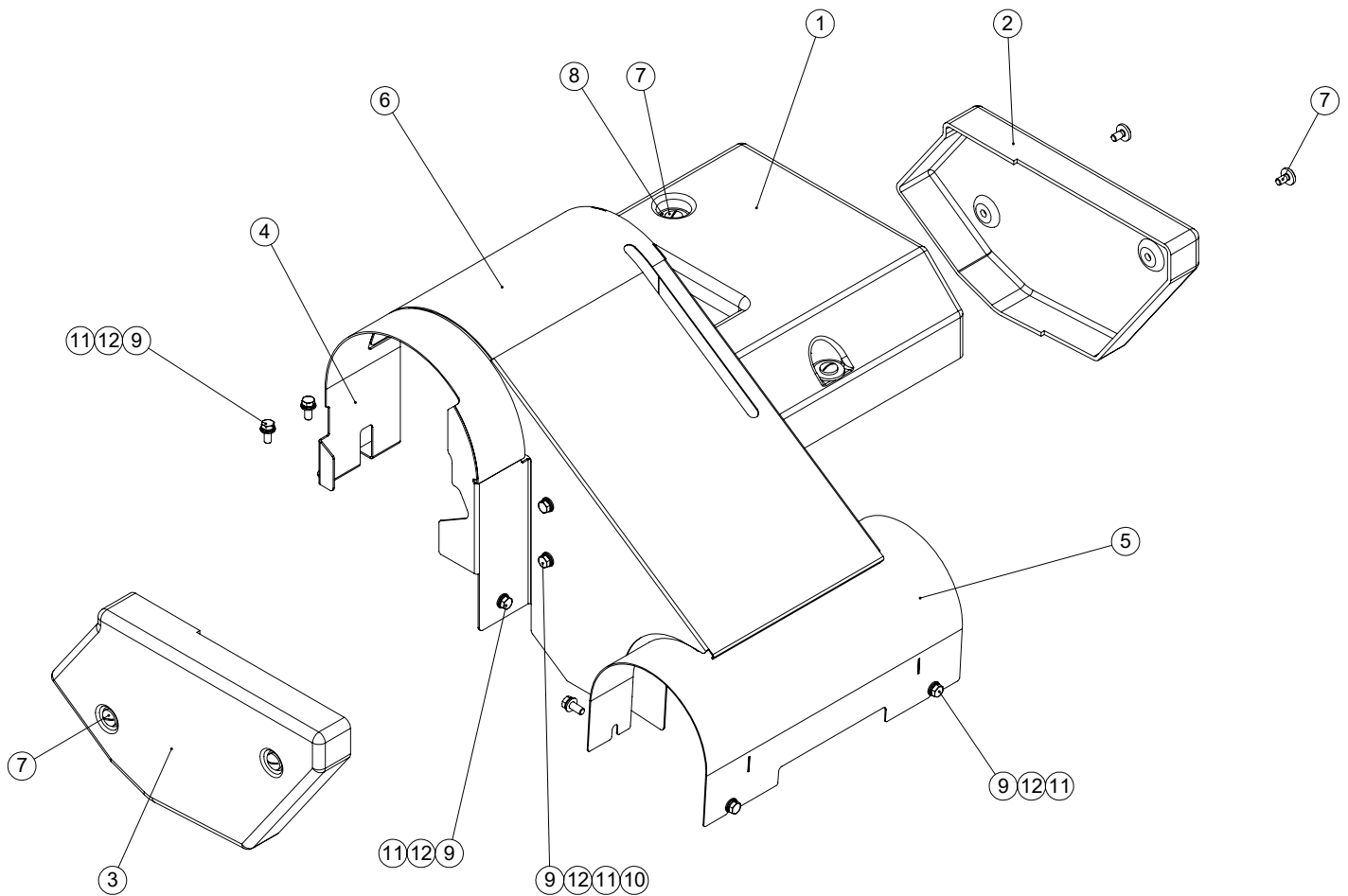

ITEM NO.	PART NUMBER	DESCRIPTION	GUARDS/QTY.
1	320190_REV0	GUARD DRIVE	1
2	320191_REV0	GUARD SIDE L.H.	1
3	320192_REV0	GUARD SIDE R.H.	1
4	320193_REV0	GUARD FLYWHEEL W.A.	1
5	320220_REV0	GUARD ASSY	1
6	320224_REV0	GUARD MAIN W.A.	1
7	J209074_REV1	BRAKE BAND COVER SCREW	6
8	J209249_REV0	WASHER 9 X 35 X 3	2
9	SP01009_REV0	HEX SET SCREW M8 X 20	12
10	SP02044_REV0	RIVNUT HEX M8 (0.5-3.0) [NO HEAD]	2
11	SP03008_REV0	WASHER M8 FORM A	12
12	SP03029_REV0	WASHER M8 SPRING LOCK	12

# DECALS

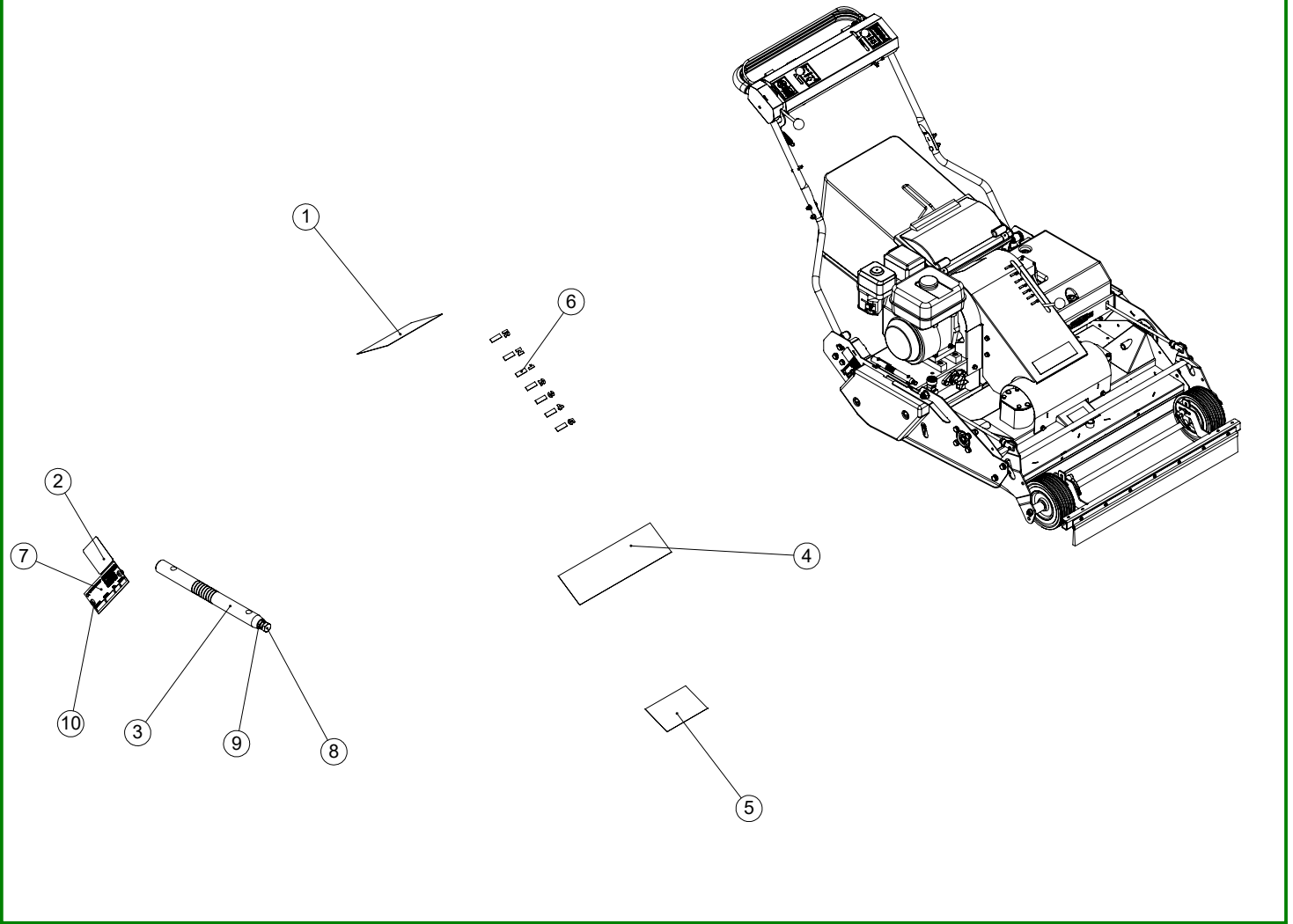

ITEM NO.	PART NUMBER	DESCRIPTION	DECALS/QTY.
1	229375_REV1	DECAL WARNING	1
2	229606_REV0	100 Db DECAL	1
3	320240_REV0	DEPTH GAUGE	1
4	B32902_REV2	DECAL DENNIS 200 X 50 (LARGE)	1
5	B32903_REV0	DECAL UNION JACK	1
6	F37466_REV2	SPEED LABEL	1
7	J20297_REV2	SERIAL NO PLATE (DENNIS)	1
8	SP01009_REV0	HEX SET SCREW M8 X 20	1
9	SP02012_REV0	NUT M8 LOCK (THIN)	1
10	SP05001_REV0	RIVET 4.8 X 10	2



## HEIGHT ADJUSTMENT AND WHEELS

ITEM NO.	PART NUMBER	DESCRIPTION	Roller + Adjuster/QTY.
1	290048_REV0	BRACE END	4
2	290053_REV0	ROLLER TORSION ARM	3
3	320082_REV0	ROLLER PIVOT BUSH	2
4	320150_REV0	TORSION BAR	1
5	320153_REV0	ADJUSTER BAR	1
6	320160_REV0	ROLLER QUADRANT ASSY L.H.	1
7	320161_REV0	ROLLER QUADRANT ASSY R.H.	1
8	320164_REV0	ADJUSTER ROD	2
9	320182_REV0	BLOCK INDEX	1
10	320183_REV0	INDEX PLATE	1
11	320189_REV0	BOSS INDEX	1
12	320230_REV0	AXLE W.A. (FRONT)	1
13	320233_REV0	WHEEL SPACER	2
14	320235_REV0	BOLT M12 GREASE	2
15	D1947_REV1	GREASE NIPPLE M6	3
16	D8299_REV1	BEARING UCFT204-20	1
17	E1-1065_REV0	WASHER M12 SPRING LOCK	4
18	F21150_REV1	BEARING BPFT5-25	2
19	F21885_REV1	BUSH AL2026 - 15	2
20	J20525_REV0	STEEL BALL 8MM	1
21	J20526_REV1	SPRING	1
22	J209112_REV1	KNOB PLASTIC	1
23	SP01020_REV0	HEX SET SCREW M10 X 40	2
24	SP01009_REV0	HEX SET SCREW M8 X 20	6
25	SP01052_REV0	CAP HEAD M10 X 35	3
26	SP01065_REV0	HEX SET SCREW M12 X 30	2
27	SP01163_REV0	ROD M12 X 210	1
28	SP02008_REV0	NUT M10 NYLOC (T)	2
29	SP02014_REV0	NUT M12 LOCK (THIN)	4
30	SP03008_REV0	WASHER M8 FORM A	6
31	SP03010_REV0	WASHER M6 FORM A	1
32	SP03011_REV0	WASHER M10 FORM A	2
33	SP03012_REV0	WASHER M12 FORM A	4
34	SP03029_REV0	WASHER M8 SPRING LOCK	6
35	SP14020_REV0	CLEVIS CLIP M12 SHORT	5
36	SP03019_REV0	WASHER M12 WAVE	2
37	320295_REV0	3mm WHEEL SHIM (03/2021 ONWARDS)	4
37	320236_REV0	1.2mm WHEEL SHIM (PRE 03/2021)	4
38	SP09007_REV0	WHEEL 200 X 73 X 25.4 (03/2021 ONWARDS)	2
38	800605_REV0	WHEEL 200 X 73 X 25.4 (PRE 03/2021)	2

# FRONT BRUSH

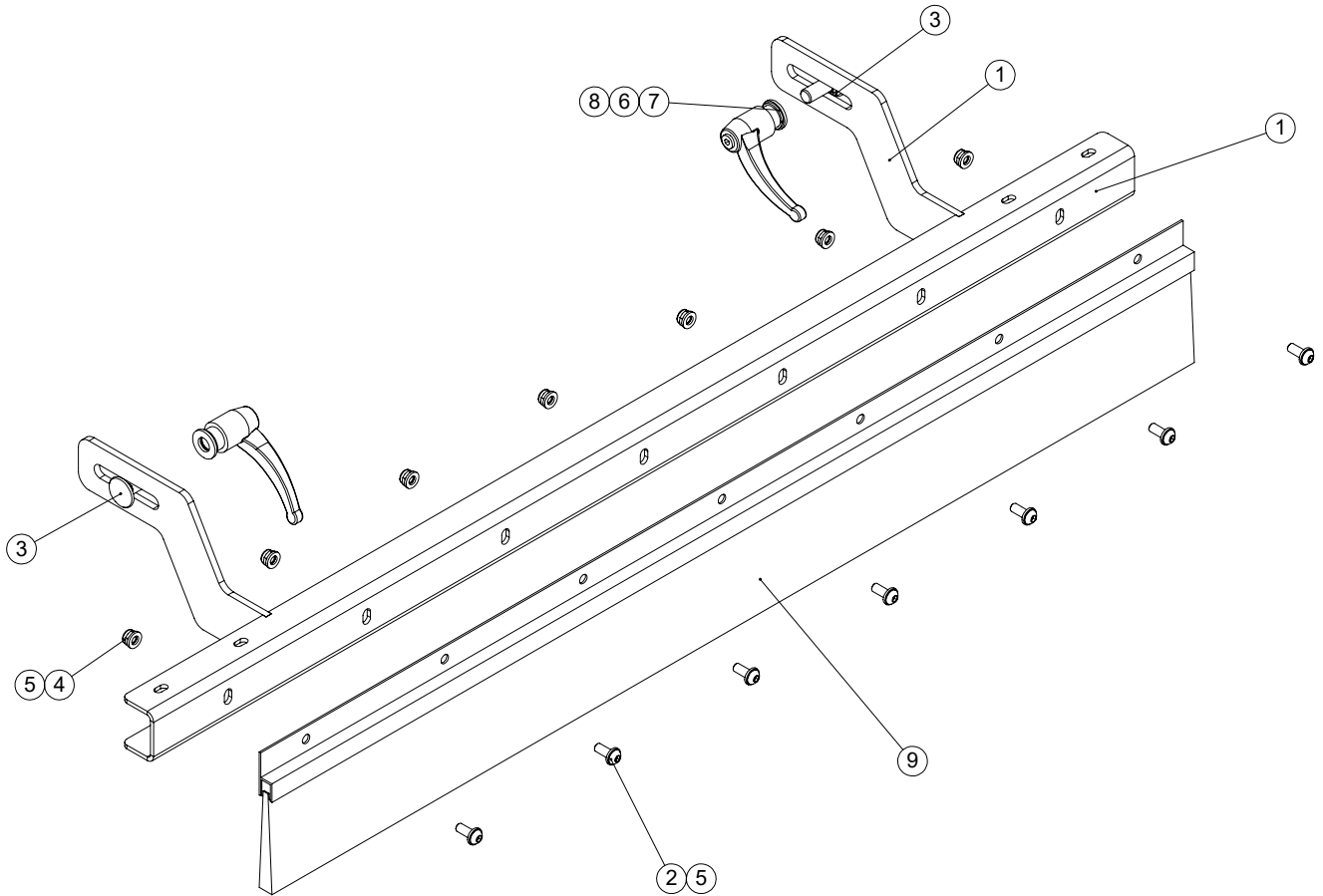

ITEM NO.	PART NUMBER	DESCRIPTION	Front Brush/QTY.
1	320290_REV0	BRUSH BAR W.A.	1
2	SP01019_REV0	BUTTON HEAD M6 X 16	7
3	SP01044_REV0	COACH BOLT M10 X 25	2
4	SP02004_REV0	NUT M6 NYLOC	7
5	SP03010_REV0	WASHER M6 FORM A	14
6	SP03011_REV0	WASHER M10 FORM A	2
7	SP03034_REV0	WASHER M10 SPRING LOCK	2
8	SP14032_REV0	HANDLE INDEX M10	2
9	SP24016_REV0	BRUSH H SECTION 8MM (75)	1



**DENNIS, Ashbourne Road, Kirk Langley, Derbyshire, DE6 4NJ, England**

**Tel: +44 (0) 1332 824 777**

**Fax: +44 (0) 1332 824 525**

**Email: [sales@dennisuk.com](mailto:sales@dennisuk.com)**

**Email: [spares@dennisuk.com](mailto:spares@dennisuk.com)**